

ROTAPULS

Incremental encoder

Series

C50



- Small size hollow shaft encoder
- Ideally suited for motor feedback applications
- Extended standard operating temperature from -40°C to 100°C
- Universal output circuit TTL/HTL 5-30Vdc
- Preferential versions with fast delivery

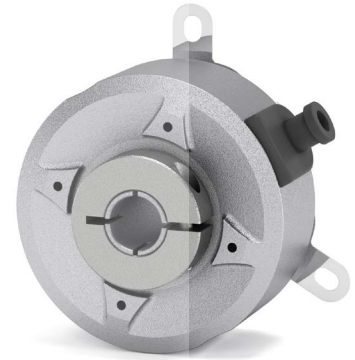

C50

ENVIRONMENTAL SPECIFICATIONS

Shock:	100 g, 6 ms
Vibrations:	10 g, 5-2000 Hz
Protection:	IP65
Operating temperature range:	-40°C +100°C (-40°F +212°F)
Storage temperature range:	-40°C +100°C (-40°F +212°F) (98% R.H. without condensation)
Option:	• IP54 Protection (low inertia bearings, 10000 rpm for short periods)

MECHANICAL SPECIFICATIONS

Dimensions:	see drawing
Hollow shaft diameter:	Ø 6, 6.35, 8, 9.52, 10 mm
Shaft loading (axial, radial):	20 N max.
Shaft rotational speed:	6000 rpm max.
Starting torque (at 20°C):	≤ 0,25 Ncm (typical)
Bearings life:	10 ⁹ rev. min.
Electrical connections:	cabl output 1 m (3.3 ft)
Weight:	~ 100 g (3,5 oz)
Options:	• additional cable

ELECTRICAL SPECIFICATIONS

Resolution (PPR):	6-10-12-25-50-100-180-200-250-256-300-360-400 500-512-600-1000-1024-1500-2000-2048-2500 4000-4096-5000-8192
Counting frequency:	100 kHz max.
Output circuits:	Push-Pull, Line Driver, Universal circuit
Power supply:	+5V±5%, +10V +30V,+5V +30V
Consumption:	70 mA (typical)
Output current (each channel):	40 mA max.
Protection:	against inversion of polarity and short-circuit (except L circuit)
EMC:	electro-magnetic immunity, according to: EN 61000-4-2 EN 61000-4-4

PREFERENTIAL MODELS

C50-H-100ZCU410	100 PPR, HTL/TTL output
C50-H-360ZCU410	360 PPR, HTL/TTL output
C50-H-500ZCU410	500 PPR, HTL/TTL output
C50-H-1000ZCU410L2	1000 PPR, HTL/TTL output
C50-H-1024ZCU410L2	1024 PPR, HTL/TTL output

MATERIALS

Flange:	aluminium die cast
Housing:	aluminium die cast
Bearings:	ABEC 5
Shaft:	stainless steel, non-magnetic - UNI EN 4305

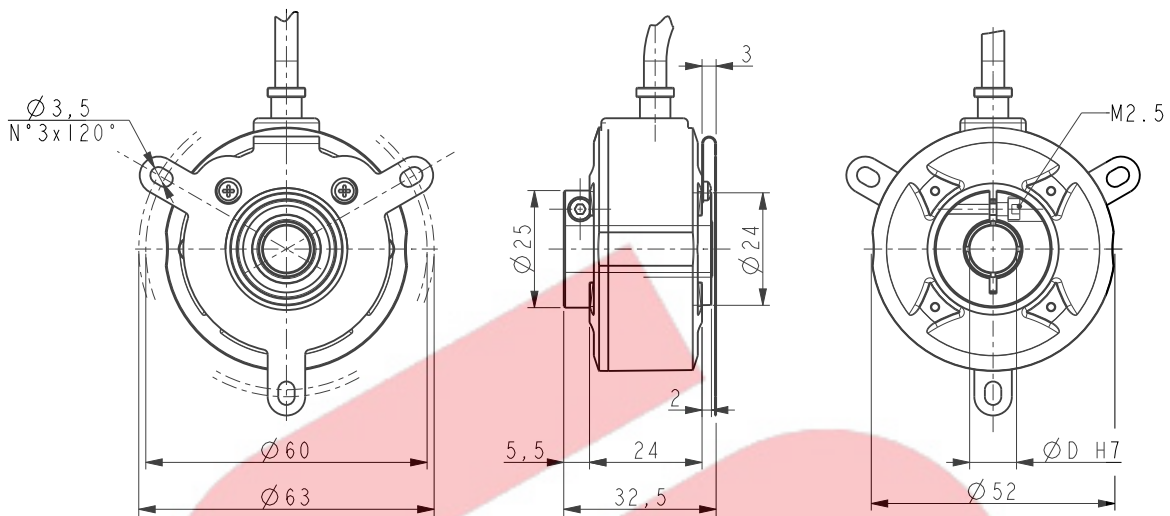

C50

Order code

C50	-	X	-	XXXX	XXX	X	XX	X	XX	/Sxxx
		(a)		(b)	(c)	(d)	(e)	(f)	(g)	(h)

(a) OUTPUT CIRCUITS

Y = Push Pull
L = Line Driver (RS422)
H = PP/LD universal circuit

(b) RESOLUTION (PPR)

See electrical specifications

(c) OUTPUT SIGNALS

BNF = AB
BCU = AB, /AB
ZNF = ABO
ZCU = ABO, /ABO

(d) SUPPLY VOLTAGE

1 = +5V \pm 5% (L output circuit)
2 = +10V \div +30V (Y output circuit)
4 = +5V \div +30V (H output circuit)

(e) SHAFT DIAMETER

6 = 6 mm
P6 = 6.35 mm - 1/4"
8 = 8 mm
P9 = 9.52 mm - 3/8"
10 = 10 mm

(f) PROTECTION

- = IP65 (standard)
V = IP54 (low inertia bearings)

(g) CABLE LENGTH

- = cable output 1 m (standard)
L2 = cable output 2 m
Lx = cable output x m

(h) CUSTOM VERSION