**X-heavy duty Hollow shaft encoder, Incremental**

- Performance hollow shaft encoder for heavy duty industries
- High vibration and shock resistance
- Electrically insulated shaft

**Mechanical data**

Operating temperature	-20 °C...+85 °C
Ingress protection class [IEC 60529]	IP67 (IP66 at shaft inlet)
Vibration [IEC 60068-2-64]	≤ 20 g, 55-2000 Hz
Shock [IEC 60068-2-27]	≤ 400 g, 3.5 ms
Shaft load max (axial/radial)	500 N / 1200 N
Rotational speed max	6000 rpm
Shaft material	Stainless steel with insulated peek insert
Cover material	Aluminium (coated)
Weight	1300 g

Encoder configuration

Code key	861007456
Type	XHI
Shaft type	Ø12 mm blind hollow shaft
Flange type	86-flange
Resolution	1024 ppr
Power supply	9-30 Vdc
Output signal	High Current HTL (HCHTL)
Connection type	Cable gland
Number of channels	6 (S00, S00\, S90, S90\, Sref, Sref\)
Cable gland dimension	M20 for Ø8-11 mm cables

Electrical data

Polarity protected	Yes
Short circuit protected incremental outputs	Yes
Current consumption (No load)	60 mA at 24 Vdc (Max. 80 mA)
Incremental output load (max)	± 40 mA
Output frequency max	200 kHz
Cable length max	350 m at 100 kHz
Channel separation	90 °el ± 25 °el
Dividing error	± 50 °el
MTTFd value [Years]	421
PFHd value [h ⁻¹]	7,43E-07

Dimensions

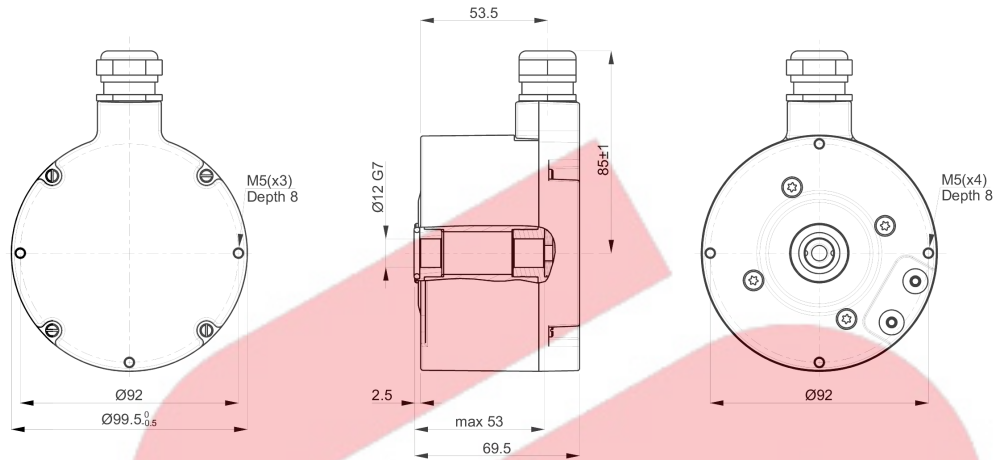

Pin Configuration

Function	Terminal
+E Volt	1
0 Volt	2
0 (Sref)	3
0 inverted (Sref\)	4
1 (S90)	5
1 inverted (S90\)	6
2 (S00)	7
2 inverted (S00\)	8
Shield	Chassis

Output signal

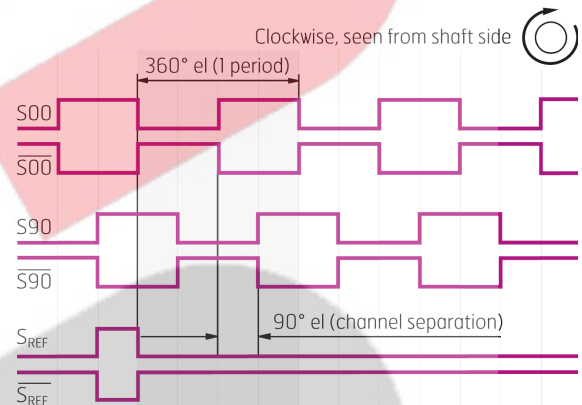

Available options

Advanced Diagnostic System
Torque bracket

Order information

Part number 750725-01