

## Flame safeguard

## LFS1...

**Flame safeguard with approval for continuous operation for the supervision of oil flames and gas flames in applications with an ionization probe and a photocell detector RAR9. Flame safeguard for intermittent operating mode with UV flame detectors QRA2 / QRA2M / QRA4 / QRA4M / QRA10 / QRA10M.**

**LFS1 and this Data Sheet are intended for OEMs using the LFS1 in or on their products.**

### Use, features

#### Use

LFS1 units are designed for the supervision of oil burners and gas burners in combination with control unit LEC1, burner control LME39.xxxRP, or with programmable logic controllers. Typical fields of application range from industrial burners up to the highest security level SIL3 and in the field of ship burners.

#### Flame supervision:

- Takes place with photocell detector RAR9 with approval for continuous operation, in the case of LFS1.1 (firing on oil).
- Takes place with an ionization probe with approval for continuous operation or with UV flame detector QRA2 / QRA2M / QRA4 / QRA4M / QRA10 / QRA10M in intermittent operation, in the case of LFS1.2 (firing on gas).

## Use, features

The flame detectors are used in conjunction with control unit LEC1 or with freely programmable controllers in the following applications:

- **Dual supervision of burners** / supervision of the main flame or of the ignition and main flame by 2 flame safeguards with the same or different flame detectors
- **Multiflame supervision** / plants with several burners whose flames must be supervised individually by one or several flame detectors, but whose startup and supervision is carried out centrally and simultaneously by only one control unit
- The flame safeguards are also used as **flame indication units** in combustion plants with manual startup

## Features

- Flame signal display via multicolor LED signal lamp
- Flame signal display via DC 0...10 V output signal (display only)
- Can be parameterized via BC interface communication interface
- Potential-free signal contacts with double insulation
- Undervoltage detection

## Supplementary documentation

Type (ASN)	Title	Documentation number	Document type
LEC1	Control unit	CC1N7761	Data Sheet
AGK11.7	Connection accessories for small burner controls	CC1N7201	Data Sheet
AZL21 / AZL23	Display and operating units	CC1N7542	Data Sheet
LFS1	Flame safeguard	CC1A7782	User documentation
ACS410	PC software for microprocessor controlled burner controls and flame safeguards	CC1J7352	Installation and Operating Instructions
OCI410	BC interface between flame safeguard and PC	CC1N7616	Data Sheet
OCI460	Cloud gateway	CC1N7600 *)	Data Sheet
QRA4 / QRA4M	UV flame detector	CC1N7711	Data Sheet
QRA2 / QRA2M QRA10 / QRA10M	UV flame detector	CC1N7712	Data Sheet
RAR9	Photocell detector	CC1N7713	Data Sheet

\*) On request



To avoid personal injury or damage to property or the environment, the following warning notes must be observed.

**Do not open, interfere with, or modify the unit.**

- All activities (mounting, installation, service, etc.) must be performed by qualified staff.
- Before making any wiring changes in the connection area, completely isolate the plant from mains supply (all-polar disconnection). Ensure that the plant cannot be inadvertently switched on again and that it is indeed dead. If this is not observed, there is a risk of electric shock
- Take suitable measures to provide protection against accidental contact at the electrical connections. If this is not observed, there is a risk of electric shock
- Press the lockout reset button / operation button of the LFS1 or the AGK20 lockout reset button extension only manually (applying a force of  $\leq 10$  N) without using any tools or pointed objects. If this is not observed, there is a risk of loss of safety functions and a risk of electric shock
- Units must not be put into operation after a fall or shock, as this can adversely affect the safety functions even if the units do not exhibit any external signs of damage. If this is not observed, there is a risk of loss of safety functions and a risk of electric shock
- Each time work has been carried out (mounting, installation, service, etc.), check that the wiring is correct. If this is not observed, there is a risk of loss of safety functions and a risk of electric shock
- The mains-powered ionization probe does not offer protection against electric shock hazards. Protection against accidental contact must be ensured. If this is not observed, there is a risk of electric shock
- An ignited UV tube is a source of UV radiation. If the flame is supervised by optical flame detectors, both detectors must be placed in a way that ensures there is **no direct visual contact** between them. If this is not observed, there is a risk of loss of safety functions.
- Connection of UV flame detectors QRA2M and QRA10M is only permitted if additional module AGK30 is used. Additional module AGK30 must always be connected within plug-in base AGK11.7 in terminal areas 1...7. If this is not observed, there is a risk of loss of safety functions and a risk of electric shock
- The data line for the AZL2 or other accessories, such as the OC1410 (plugs into the BC interface), must only be connected or disconnected when the unit is dead (all-polar disconnection), since the BC interface does not ensure safe separation from the mains voltage. If this is not observed, there is a risk of electric shock
- Intermittent operation: For safety reasons – self-test of the flame supervision circuit, etc. – at least one controlled shutdown must take place every 24 hours for applications with LFS1.2 and UV flame detectors QRA2 / QRA2M / QRA4 / QRA4M / QRA10 / QRA10M. If this is not observed, there is a risk of loss of safety functions
- The separating plate supplied can be installed in the area between connection terminals 9 and 12, and the other terminals (1 to 7), as a means of achieving double insulation, refer to the *Installation notes* chapter. It is particularly important that the wiring is handled and installed correctly and as specified in the area around the terminals. Failure to observe these instructions poses a risk of loss of safety functions and a risk of electric shock
- The 0...10 V voltage output terminal 7 is not double-insulated from the mains voltage. It is important to bear this in mind when selecting measuring equipment (at least CAT III). If this is not observed, there is a risk of electric shock

**Standards and certificates**

Only in conjunction with the flame detectors



**Applied directives:**

- Low Voltage Directive 2014/35/EU
- Pressure Equipment Directive 2014/68/EC
- Gas Appliances Regulation (EU) (EU) 2016/426
- Electromagnetic Compatibility EMC (immunity) \*) 2014/30/EU

\*) The compliance with EMC emission requirements must be checked after the flame safeguard is installed in equipment

Compliance with the regulations of the applied directives is verified by the adherence to the following standards / regulations:

- Automatic burner control systems for burners and appliances burning gaseous or liquid fuels DIN EN 298
- Safety and control devices for burners and appliances burning gaseous and/or liquid fuels — General requirements DIN EN 13611
- Automatic electrical controls Part 2-5: Particular requirements for automatic electrical burner control systems DIN EN 60730-2-5

The edition of the standards that applies in each case can be found in the declaration of conformity.

**Note on DIN EN 60335-2-102**  
 Household and similar electrical appliances – Safety Part 2-102:  
 Particular requirements for gas, oil, and solid-fuel burning appliances having electrical connections. The electrical connections of the LFS1 and the AGK11.7 comply with the requirements of EN 60335-2-102.



EAC Conformity (Eurasian Conformity)



UKCA conformity mark (UK compliance)



China RoHS  
 Hazardous substances table:  
<http://www.siemens.com/download?A6V10883536>

LFS1.11Ax	+	+	+	+	+	+	+	+
LFS1.21Ax	+	+	+	+	+	+	+	+



LFS1.11Ax	+	+
LFS1.21Ax	+	+

## Standards and certificates (continued)

Marine approvals:  
 Det Norske Veritas: Classification A A A A  
 Germanischer Lloyd: Classification A  
 Bureau Veritas EC Code: 31

SIL3 classification to EN 13611:2014:

# SIL3

Suitable for use in safety-related, industrial applications up to safety level SIL3 (safety integrity level 3).

The following parameters apply:

Type (ASN)	Flame detector	Operating mode	Safety integrity level up to	PFHD [1/h]	MTTFd [y]	SFF
LFS1.11A1 LFS1.11A2	RAR9	Continuous operation	SIL3	1.80E-08	6500	≥99%
LFS1.21A1 LFS1.21A2	Ionization probe	Continuous operation	SIL3	1.80E-08	6500	≥99%
LFS1.21A1 LFS1.21A2	QRA2 / QRA2M, QRA4 / QRA4M, QRA10 / QRA10M	Intermittent	SIL2	2.30E-07	510	≥99%
LFS1.21A1 LFS1.21A2	Ionization probe + QRA2 / QRA2M, QRA4 / QRA4M, QRA10 / QRA10M	Intermittent	SIL2	2.30E-07	510	≥99%

 **Note**  
 The information on the safety integrity level (SIL) relates to a designed lifetime of up to 10 years.

## Life cycle

The flame safeguard has a designed life cycle\* of 250,000 burner startup cycles which, under normal operating conditions in heating mode and nominal switching loads, corresponds to approx. 10 years of service (starting from the date of manufacture on the nameplate). For industrial applications with reduced switching loads of a maximum of 0.1 A, the flame safeguard has an increased designed life cycle\* of up to 1,000,000 burner startup cycles.

This life cycle is based on the endurance tests specified in standards EN 13611 and EN 298. A summary of the conditions has been published by the European Control Manufacturers Association (Afecor) ([www.afecor.org](http://www.afecor.org)).

\* The designed life cycle is based on use of the flame safeguard according to the manufacturer's data sheet. In this case, it is advisable to perform a safety check or replace the unit. The designed life cycle is not the warranty time specified in the Terms of Delivery.

## Commissioning notes

Concerning connection diagram 7782a06, connection example of two manually operated burners: Ensure that the drop-out delay time of external relay  $\tau$  is not greater than 50 ms.

## Mounting notes

- Ensure that the relevant national safety regulations are complied with
- The flame safeguards can be mounted in any position on the burner, in the control cabinets, or on the control panels
- The plug-in base AGK11.7 is available for mounting and is designed for cable entry from the front, the side, or below.  
4 earth terminals provide connections for the earth conductors of burner plant components such as the ignition transformer. The flame safeguards themselves are double-insulated; refer to the *Installation notes* chapter
- The separating plate must be connected so that it is flat/level with the plug-in base; refer to red hatched area

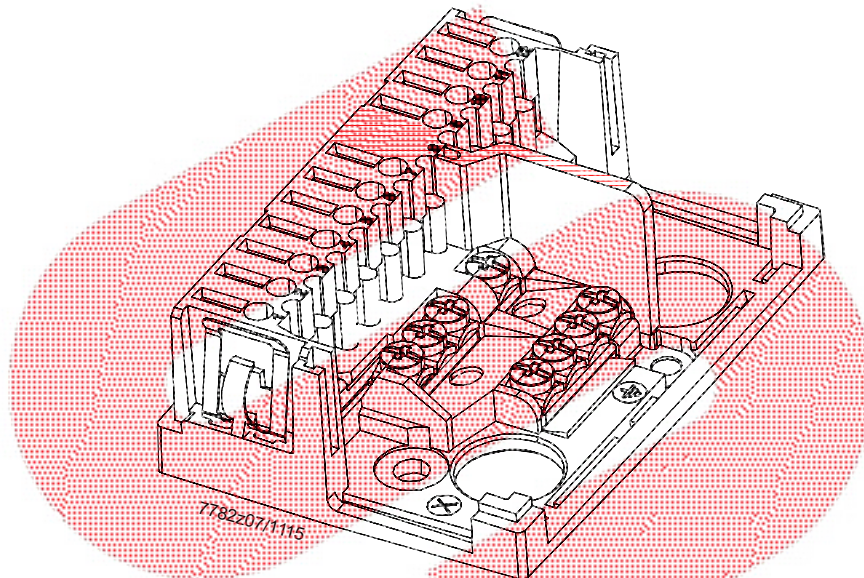

- The separating plate must only be plugged into terminal 8

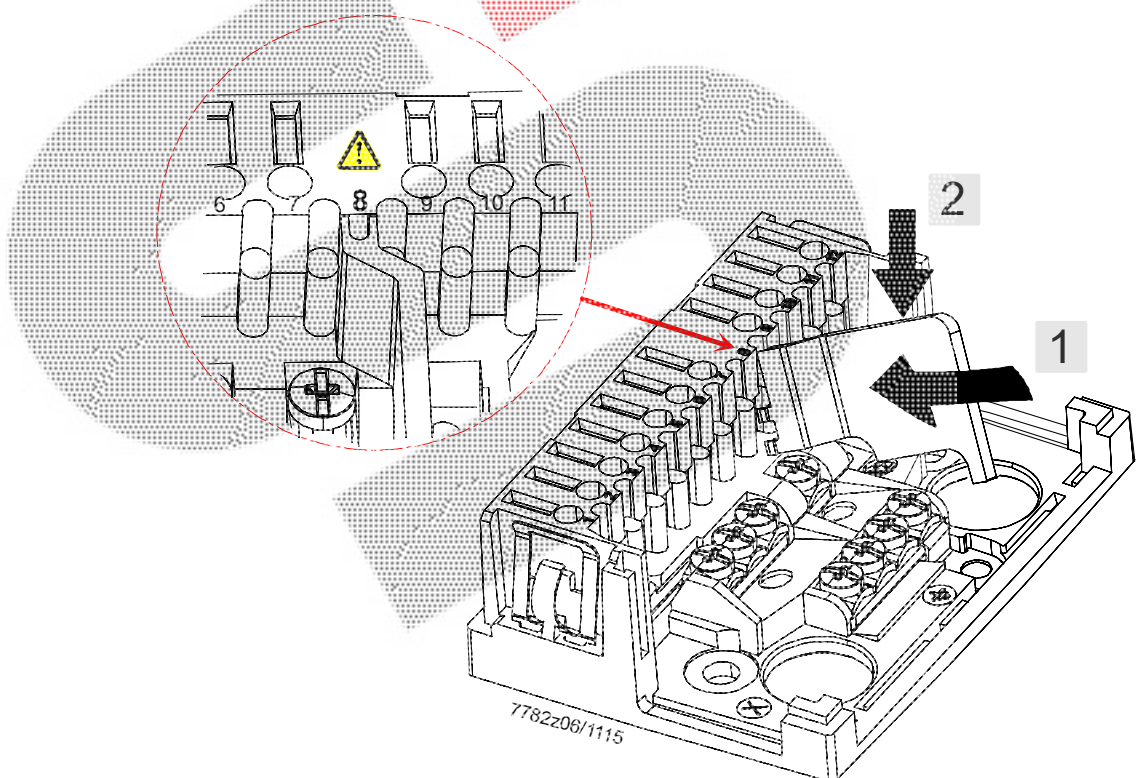

- Always run the high-voltage ignition cables separately from the unit and other cables while observing the greatest possible distances
- When wiring, ensure that there is enough free space for the BC interface connection jack
- Do not mix up phase and neutral conductors

### Note!

For use in power supply systems with non-grounded neutral conductors!  
Power supply systems with earthed neutral conductors form the basis of the diagrams and circuit diagrams of the LFS1 in this Data Sheet. In power supply systems with non-earthed neutral conductors, terminal 2 of the LFS1 must be connected to the earth conductor via the RC unit ARC 4 668 9066 0 for ionization current supervision. It must be made certain that local regulations are complied with (e.g., protection against electric shock) since 120 V AC (50 / 60 Hz) or 230 V AC (50 / 60 Hz) mains voltage produces peak leakage currents of 2.7 mA.

### Note!

Double insulation.

The flame safeguards LFS1 and the terminal bases AGK11.7 including separating plate element are double-insulated between the terminal areas 1...7 and 9...12. This means that they feature strengthened insulation; refer also to the *Technical data* chapter. If the double insulation needs to be present up to the connected components, the separating plate element included in the scope of delivery of the AGK11.7 must be installed in all cases (marked with an arrow in the figure below). As an alternative, other suitable measures can also be put in place. Safe separation can only be ensured if all connected components are fitted with a safe separation facility and the components have been wired as specified. In particular, compliance with the relevant warning notes must be ensured.

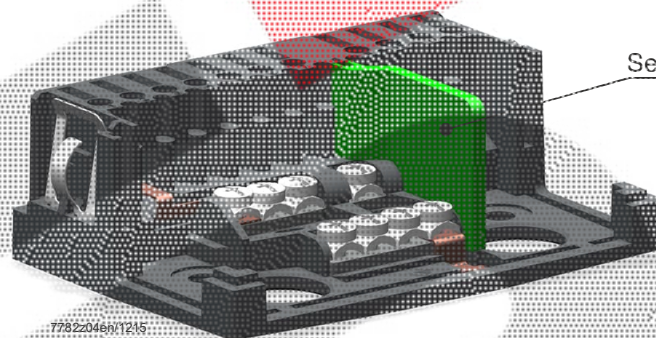

### Note!

When using QRA2M and QRA10M!

Connect additional module AGK30 in accordance with connection diagram 7782a14.

The ground terminal of plug-in base AGK11.7 (symbol  $\oplus$ ) must be permanently connected to the burner ground. Additional module AGK30 must always be connected within plug-in base AGK11.7 in terminal areas 1...7. If this is not observed, there is a risk of loss of safety functions and a risk of electric shock.

## Electrical connection of the flame detectors

---

It is important to achieve practically disturbance-free and loss-free signal transmission:

- Never run detector cables together with other cables
  - Line capacitance has an impact on the flame signal
  - Use a separate cable
- The ionization probe does not offer protection against electric shock
- Position the ignition electrode and the ionization probe so that the ignition spark cannot arc over to the ionization probe, risk of electrical overloads
- Observe the permissible detector cable lengths; refer to the *Technical data*
- Mount and adjust the flame detector so that it only detects the flame to be supervised in each case
- Connection of UV flame detectors QRA2M and QRA10M is only permitted if additional module AGK30 is used
- Protect the UV cell adequately against the following UV sources: halogen lamps, welding equipment, special lamps, ignition sparks, as well as high-energy X-rays and gamma rays
- Polarity or short circuit at the connection terminals of the RAR9 does not lead to a flame signal
- Polarity at the connection terminals of UV flame detectors QRA2 / QRA2M / QRA4 / QRA4M / QRA10 / QRA10M does not lead to a flame signal.  
A short circuit at the connection terminals of UV flame detectors QRA2 / QRA2M / QRA4 / QRA4M / QRA10 / QRA10M leads to:
  - Fault code Loc: 10: at operating level (terminal 6 of the LFS1 active)
  - No flame signal: test level (terminal 6 of the LFS1 inactive)
- In general the terminal 5 of LFS1 must not be grounded! When replacing a LFE10 by a LFS1.2 it is particularly important that the ground connection has to be removed from terminal 10 at the terminal base of LFE10. The ground connection of QRA10 has to remain unaltered in order to ensure the protection class 1.
- If the ionization electrode connected to the burner ground short-circuits, there is no flame signal

## Disposal notes

---

The LFS1 contains electrical and electronic components and must not be disposed of together with domestic waste. Local and currently valid legislation must be complied with.

## Design

### LFS1 features

Microprocessor-based flame safeguards LFS1 have a plug-in design and consist of the power supply section, flame signal amplifier, and flame relay with potential-free contacts. There is also an operating button with an integrated LED signal lamp, which is located under a viewing window. The LED is used to provide a multicolor indication of error status and operational status messages, concerning flame signal strength, for instance. The flame signal strength can also be measured as a 0...10 V DC signal using a commercially available voltmeter (at least CAT III) at terminal 7.

Communicating via the BC interface:

On the underside of the LFS1 in the base area, there is a communication interface (BC interface), which is used to change parameters or provide a numerical indication of the flame signal. When the display and operating unit AZL2 is connected, it is possible to change parameters such as the flame signal flame-on and flame-out response times. In addition, the flame signal strength can also be displayed permanently during continuous burner operation.

Using with the control unit LEC1:

The electrical circuit of the LFS1 is intrinsically safe and, in conjunction with the control unit LEC1, is tested for proper functioning each time the burner is started up. An automatic extraneous light test is performed by increasing the sensitivity of the amplifier during the burner off and purging times of the control unit LEC1. An automatic flame detector test is performed by increasing the operating voltage of the UV tubes during the burner off and purging times of the control unit LEC1. In the case of applications with other control units – such as programmable logic controllers – the extraneous light test can be activated via the control input at terminal 6. This is not required for ionization supervision.

### Undervoltage

- Flame OFF signal: From operating position if mains voltage drops lower than approx. 80 V AC (at  $U_N = 120 \text{ V AC}$ )
- Flame ON signal: Restart is initiated if mains voltage exceeds approx. 85 V AC (at  $U_N = 120 \text{ V AC}$ )
- Flame OFF signal: From operating position if mains voltage drops lower than approx. 165 V AC (at  $U_N = 230 \text{ V AC}$ )
- Flame ON signal: Restart is initiated if mains voltage exceeds approx. 170 V AC (at  $U_N = 230 \text{ V AC}$ )

### Overvoltage

No shutdown if the voltage limit exceeds  $U_N + 10\%$ .

Flame supervision	Flame detector	Data Sheet
	QRA2 / QRA2M, QRA10 / QRA10M	N7712
	QRA4 / QRA4M	N7711
	RAR9	N7713
	Ionization probe (must be supplied by customer)	---

Using an ionization probe

Flame supervision by making use of the electrical conductivity of the flame in conjunction with the rectifying effect is only possible with gas and blue-flame burners. Since the flame signal amplifier responds only to the DC component of the flame signal (ionization current), a short circuit between the flame detector and functional earth cannot simulate a flame signal. Single-electrode operation, i.e., ignition and supervision with a single electrode, is not possible. Do not activate the test mode switchover using terminal 6 during flame supervision with ionization probes. Terminal 6 must be connected directly to the phase conductor at terminal 1 in this case.

Using an ionization probe and a UV flame detector QRA

It is possible to connect an ionization probe and a UV flame detector QRA to the LFS1.2 at the same time.

The flame assessment behaves as follows:

Ionization probe	UV flame detector QRA	LFS1.2 flame assessment
OFF	OFF	OFF
ON	OFF	ON
OFF	ON	ON
ON	ON	ON

## Type summary and ordering information

The type references given below apply to the LFS1 without plug-in base and without flame detector. For ordering information for plug-in bases and other accessories; refer to *Accessories*.

Part no.	Type	Nominal voltage	Use	Flame detector	BC interface connection	Output 0...10 V	Times			Comparison types <sup>2)</sup>
							tw max.	tan <sup>1)</sup> min.	tab <sup>1)</sup> max.	
BPZ:LFS1.11A2	LFS1.11A2	AC 230 V	Oil	RAR9...	•	•	5 s	0.3 s	1 s	LAE10
BPZ:LFS1.21A2	LFS1.21A2	AC 230 V	Gas / oil	ION QRA2 / QRA2M QRA4 / QRA4M QRA10 / QRA10M	•	•	5 s	0.3 s	1 s	LFE10
BPZ:LFS1.11A1	LFS1.11A1	AC 120 V	Oil	RAR9...	•	•	5 s	0.3 s	1 s	LAE10-110V
BPZ:LFS1.21A1	LFS1.21A1	AC 120 V	Gas / oil	ION QRA2 / QRA2M QRA4 / QRA4M QRA10 / QRA10M.C	•	•	5 s	0.3 s	1 s	LFE10-110V
Range adjustment for times (those are added up to the hours indicated above)							From	(Parameter 217.00) 0 s	(Parameter 217.01) 0 s	
							To	(Parameter 217.00) 11.907 s	(Parameter 217.01) 11.907 s	
							Increment	0.147 s	0.147 s	
							Factory setting	0 s	0 s	

### Key

tw Waiting time

tan Flame signal flame-on response time

tab Flame signal flame-out response time

Corresponds to the detection time in the event of a loss of flame (FFDT) EN 298

<sup>1)</sup> Factory setting: Refer to note on parameterization

<sup>2)</sup> Flame safeguards LFS1 are intended to replace the relevant comparison types

Note on parameterization:

Use the display and operating unit (display) AZL2 to ensure that the exact value of the required time is always set as multiples of increments of 0.147 seconds. When parameterizing minimum or maximum times, a potential tolerance of  $\pm 7\%$  must be taken into consideration.

The following applies to **minimum** values: At least one value which is 7% **greater** must be parameterized.

The following applies to **maximum** values: At least one value which is 7% **smaller** must be parameterized.



Example 1: The flame signal flame-out response time  $t_{ab}$  must not be set above 5 seconds  
Calculation:  $(5 \text{ seconds} - 1 \text{ second}) - 7\% = 3.65 \text{ seconds}$

Value to be parameterized

(parameter 217.01): Must be the same as or **smaller** than the calculated value (e.g., 3.528 seconds)

Example 2: The flame signal flame-on response time  $t_{an}$  must be set to at least 5 seconds





Calculation:  $(5 \text{ seconds} - 0.3 \text{ seconds}) + 7\% = 5.05 \text{ seconds}$

Value to be parameterized

(parameter 217.00): Must be the same as or **greater** than the calculated value (e.g., 5.145 seconds)

## Accessories

To be ordered separately:

<b>Flame detector</b>	UV flame detector <b>QRA2</b> Refer to Data Sheet N7712.	
	UV flame detector <b>QRA4</b> . Refer to Data Sheet N7711.	
	UV flame detector <b>QRA10</b> Refer to Data Sheet N7712.	
	Photocell detector <b>RAR9</b> Refer to Data Sheet N7713.	
	<b>Ionization probe</b> Flame detector for use with Siemens burner controls for the supervision of gas flames. Supplied by customer.	
<b>Connection accessories for small burner controls</b>	Plug-in base <b>AGK11.7</b> Article no.: <b>BPZ:AGK11.7</b> <ul style="list-style-type: none"><li>• To connect the flame safeguard LFS1 to the burner plant</li><li>• 11-pole screw terminals</li><li>• With enclosed plastic separating plate to ensure safe separation between terminals 9 and 12 and terminals 1 and 7</li><li>• Black plastic</li></ul> Refer to Data Sheet N7201.	
	Cable gland holder <b>AGK65</b> Article no.: <b>BPZ:AGK65</b> For up to 5 Pg11 cable glands. Refer to Data Sheet N7201.	
	Cable gland holder <b>AGK65.1</b> Article no.: <b>BPZ:AGK65.1</b> For up to 5 M16 x 1.5 cable glands. Refer to Data Sheet N7201.	

## Accessories (continued)

To be ordered separately:

### Others

RC unit **ARC46689066 0**

Article no.: **BPZ:ARC466890660**

For the supervision of ionization currents in networks with non-earthed neutral conductor.



**Mounting clip** for support rail

(The suitability for the particular application has to be ensured by the user)

Order no. **2309.000**

Rittal GmbH & Co. KG

Auf dem Stützelberg

35745 Herborn, Germany

Phone: +49 (0) 2772 / 505-0

Fax: +49 (0) 2772 / 505-2319

www.rittal.de

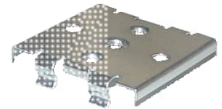

Reset button extension **AGK20**

Article no.: **BPZ:AGK20**



Adapter **KF8896**

Article no.: **BPZ:KF8896**

- Adapter for replacing LAE10 and LFE10 with LFS1.
- Ensures mechanical height adjustment and correct terminal assignment

Refer to dimensions.



Signal cable **AGV50.100**

Article no.: **BPZ:AGV50.100**

Signal cable for AZL2, with RJ11 connector, cable length 1 m, pack of 10.



Signal cable **AGV50.300**

Article no.: **BPZ:AGV50.300**

Signal cable for AZL2, with RJ11 connector, cable length 3 m, pack of 10.

Additional module **AGK30**

Article no.: **S55856-Z301-A100**

- For establishing compatibility of the LFS1.2 with QRA2M and QRA10M
- With 4 connecting wires for connection in plug-in base AGK11.7



**Accessories (continued)**

To be ordered separately:

**Service tools**

Optical interface **OCI400**

Article no.: **BPZ:OCI400**

- Optical interface between flame safeguard and PC
- Facilitates viewing and recording setting parameters on site using the ACS410 PC software

Refer to Data Sheet N7614.



Service tool between burner control and PC. Facilitates viewing, processing, and recording setting parameters on site using the ACS410 PC software. Refer to Data Sheet CC1N7616.

Article no.	Type	
<b>BPZ:OCI410.30</b>	<b>OCI410.30</b>	<ul style="list-style-type: none"> <li>• Heating engineer version (standard)</li> <li>• Parameter change possible for the <i>Heating engineer</i> password level</li> </ul>
<b>BPZ:OCI410.40</b>	<b>OCI410.40</b>	<ul style="list-style-type: none"> <li>• OEM variant</li> <li>• Parameter change possible for the <i>OEM and heating engineer</i> password level</li> </ul>



PC software **ACS410**

Article no.: **BPZ:ACS410**

PC software for parameterization and visualization of the burner control.

On request.

Refer to Software Documentation J7352.



**OCI460** cloud gateway

Climatix IC communication gateway and Modbus interface with galvanic separation for burner controls, burner management systems, or flame safeguards equipped with Modbus or BC interface communication.

Refer to Data Sheet N7600.

**OCI460.10**

Article no.: **S55666-J401-A100**

- European variant

**OCI460.11**

Article no.: **S55666-J402-A100**

- Chinese variant



## Accessories (continued)

To be ordered  
separately:

### Display and operating unit

Display and operating unit **AZL21.00A9**

Article no.: **BPZ:AZL21.00A9**

Separate unit, choice of mounting methods, 8-digit LCD, 5 buttons, BC interface for LFS1, degree of protection IP40. Refer to Data Sheet N7542.

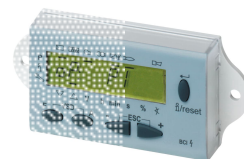

Display and operating unit **AZL23.00A9**

Article no.: **BPZ:AZL23.00A9**

Separate unit, choice of mounting methods, 8-digit LCD, 5 buttons, BC interface for LFS1, degree of protection IP54. Refer to Data Sheet N7542.

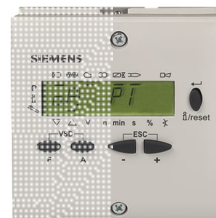

## Technical data

General unit data	Mains voltage (rated voltage)	For grounded and non-grounded networks 120 V AC (also suitable for 100 V AC networks).
	• LFSx.xxA1	230 V AC
	• LFSx.xxA2	50...60 Hz
	Mains frequency	5 VA
	Internal consumption	Overvoltage category III: 4 kV for the entire LFS1 unit 2.5 kV for the creepage distances or air gaps due to voltage limitation measures
	Rated surge voltage	Overvoltage category III and degree of contamination 2 for 230 V AC in accordance with DIN EN 60730-1: - Reinforced insulation between terminal areas 1...7 and 9...12 - Normal insulation between terminal areas 9...10 and 11...12
	Basis of calculation for air gaps and creepage distances	Max. T6.3H250V to IEC 60127-2
	External primary fuse (Si) (optional)	
	 <b>Caution!</b> <b>Risk of damage to the switching contacts!</b> <b>If the external primary fuse (Si) is blown due to overload or short-circuit at the terminals, the LFS1 must be replaced.</b>	
	Internal fuse for terminals 11 / 12 (fuse cannot be replaced)	T1.6L250V to IEC 60127-4
	External current limitation for terminals 9 / 10	Example: External fuse T1.6A
	Permissible mounting position	Optional
	Weight	
	• LFS1.11A1	115 g
• LFS1.11A2	115 g	
• LFS1.21A1	148 g	
• LFS1.21A2	144 g	
Safety class	To DIN EN 60730-1: For applications without safe separation. Protection against electric shock is achieved through double or reinforced insulation. Provision for the protective earth connection is made in the plug-in base AGK11.7. When replacing LAE10 / LFE10 with KF8896 and LFS1, the maximum safety class that can be achieved is I.	
• Safety class I	For applications with safe separation. Protection against electric shock is achieved through double or reinforced insulation.	
• Safety class II		
Degree of protection	IP40, to be ensured through mounting	
Degree of contamination	Degree of contamination 2 to DIN EN 60730-1	
Software class	Class C to DIN EN 60730-2-5 2-channel structure	
Minimum flame safeguard self-test frequency	2 x per second for continuous operation with ionization probe or RAR9	
Detection time in the event of loss of flame	Max. 1 s for LFS1 (including flame detector)	
Reaction time in the event of loss of flame	Max. 1 s for LFS1 with LEC1	
Voltage output at terminal 7	DC 0...10 V Increment DC 40 mV	

Permissible cable lengths	At a line capacitance of 100 pF/m, unshielded For longer distances, use <b>low-capacitance</b> cables, maximum 2 nF total, unshielded
• Terminals 3	Max. 20 m Run detector cables separately, at least 5 cm away from other cables
• Terminals 4 and 5	Max. 20 m For >10 m, use a shielded cable and connect the shield to PE at one end. Run detector cables separately, at least 5 cm away from other cables.
• Terminal 6	Max. 20 m
• Terminal 7	Max. 3 m
• Terminals 9 to 12	Max. 20 m Max. 300 m For longer distances, use <b>low-capacitance</b> cables, maximum 2 nF total, unshielded. In the event of reduced current rating of max. 0.01 A, 24 V DC / 24 V AC and $\cos\phi = 1$ . The Ölflex Smart cable type 108 / 4 x 0.75 mm <sup>2</sup> is ideal.
• BC interface connection	Max. 3 m

Connectable cross-sectional areas AGK11.7	
• Terminals 1...7 and 9...12	Min. 0.5 mm <sup>2</sup> and max. 1.5 mm <sup>2</sup> Solid or stranded wire with ferrule
• Auxiliary terminals N, PE, 31	Min. 0.50 mm <sup>2</sup> and max. 1.5 mm <sup>2</sup> Solid or stranded wire with ferrule (when connecting 2 solid or stranded wires per terminal, the same cross-sectional areas must be used for each terminal)

Specifications as per EN 60730-1:	
Type of shutdown or interruption of each circuit	Shutdown with micro switch, 1-pole Mode of operation type 2 B

Perm. current rating	
Terminals 3 and 5 (flame detectors)	Refer to <i>Flame detectors</i> chapter
Terminal 6 (test mode switchover)	Max. 1 mA
Terminal 7 (voltage output 0...10 V)	Max. 0.1 mA
Terminals 11 and 12 (NO switching output)	Max. 1 A, $\cos\phi \geq 0.6$ For a maximum of 250,000 burner startup cycles Max. 0.1 A, $\cos\phi = 1$ For a maximum of 1,000,000 burner startup cycles
Terminals 9 and 10 (NC switching output)	Max. 0.1 A, $\cos\phi \geq 0.6$ For a maximum of 250,000 burner startup cycles Max. 0.1 A, $\cos\phi = 1$ For a maximum of 1,000,000 burner startup cycles

Technical data (continued)

Permissible switching voltage	
Terminal 6 (test mode switchover)	Mains voltage +10%
Terminals 11 and 12 (NO switching output)	DC 125 V AC 250 V
Terminals 9 and 10 (NC switching output)	DC 125 V AC 250 V

Environmental conditions

<b>Storage</b>	EN 60721-3-1:1997
Climatic conditions	Class 1K3
Mechanical conditions	Class 1M2
Temperature range	-20...+60°C
Humidity	<95% r.h.
<b>Transport</b>	EN 60721-3-2:1997
Climatic conditions	Class 2K2
Mechanical conditions	Class 2M2
Temperature range	-20...+60°C
Humidity	<95% r.h.
<b>Operation</b>	EN 60721-3-3:1995 + A2:1997
Climatic conditions	Class 3K5
Mechanical conditions	Class 3M2
Temperature range	-20...+60°C
Humidity	<95% r.h.
Installation altitude	Max. 2,000 m above sea level



**Attention!**  
 Condensation, formation of ice, and ingress of water are not permitted. If this is not observed, there is a risk of loss of safety functions and a risk of electric shock.

Signal cable AGV50  
 Display → BC interface

<b>Signal cable</b>	To connect display and operating unit AZL2 White, unshielded cable internal conductor 4 x 0.141 mm <sup>2</sup>
	Each cable with 2 RJ11 connectors
Cable length AGV50.100	1 m
Cable length AGV50.300	3 m
Place of installation for signal cable with connector	Under the burner hood (additional measures for SKII to EN 60730-1)

## Technical data (continued)

### Measuring circuits for detector current measurement

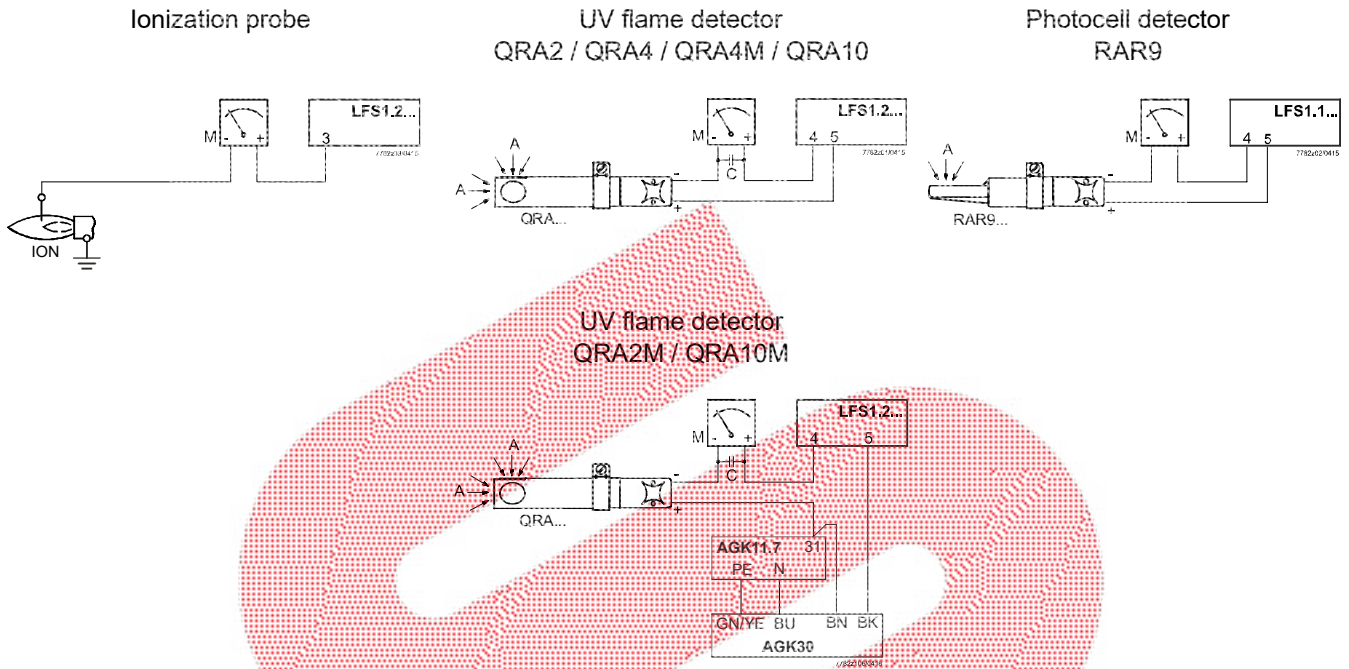

#### Key

- A Incidence of light from the flame
- C Electrolytic capacitor 100  $\mu$ F, 10 V DC
- ION ionization probe
- M DC microammeter, internal resistance  $\leq 5,000 \Omega$
- QRA UV flame detector
- RAR9 Photocell detector



#### Attention!

High-voltage ignition may affect the ionization current.

Possible remedy: Swap the ignition transformer's primary connection.

## Technical data (continued)

Flame supervision with ionization probe	At mains voltage	
	120 V AC	230 V AC
<b>Values apply to factory setting of parameters 182 = 0</b>		
Detector voltage between ionization probe and ground (AC voltmeter $R_i \geq 10 \text{ M}\Omega$ )	Approx. 270 V AC	Approx. 270 V AC
Switching threshold (limit values):		
Switching on (flame ON) (DC ammeter $R_i \leq 5 \text{ k}\Omega$ )	$\geq \text{DC } 1.5 \mu\text{A}$	$\geq \text{DC } 1.5 \mu\text{A}$
Switching off (flame OFF) (DC ammeter $R_i \leq 5 \text{ k}\Omega$ )	$\leq \text{DC } 0.5 \mu\text{A}$	$\leq \text{DC } 0.5 \mu\text{A}$
Detector current required for reliable operation	$\geq \text{DC } 3 \mu\text{A}$	$\geq \text{DC } 3 \mu\text{A}$
Switching threshold in the event of poor flame during operation (LED flashes green)	Approx. DC 2 $\mu\text{A}$	Approx. DC 2 $\mu\text{A}$
Possible detector current with flame (typical)	20 $\mu\text{A}$ DC	20 $\mu\text{A}$ DC
<b>Flame supervision with UV flame detector QRA2 / QRA2M / QRA4 / QRA4M / QRA10 / QRA10M</b>	At mains voltage	
<b>Values apply to factory setting of parameters 182 = 0</b>	<b>120 V AC</b>	<b>230 V AC</b>
Detector voltage at QRA2 / QRA2M / QRA4 / QRA4M / QRA10 / QRA10M (with no load)		
Terminal 6 OFF (test mode)	Approx. 290 V AC	Approx. 290 V AC
Terminal 6 ON (operating mode)	Approx. 250 V AC	Approx. 250 V AC
Switching threshold (limit values):		
Switching on (flame ON)	$\geq 20 \mu\text{A DC}$	$\geq 20 \mu\text{A DC}$
Switching off (flame OFF)	$\leq 5 \mu\text{A DC}$	$\leq 5 \mu\text{A DC}$
Detector current required for reliable operation	$\geq 24 \mu\text{A DC}$	$\geq 24 \mu\text{A DC}$
Switching threshold in the event of poor flame during operation (LED flashes green)	Approx. 24 $\mu\text{A DC}$	Approx. 24 $\mu\text{A DC}$
Possible detector current with flame (typical):		
Test mode	700 $\mu\text{A}$	700 $\mu\text{A}$
Operating mode	550 $\mu\text{A}$	550 $\mu\text{A}$

### Notes

Lifetime of the UV cell.

UV cells and the QRA2/QRA4/QRA10 are subject to wear and tear and must be replaced as part of regular maintenance, at the latest at the end of the average lifetime of the UV cell. The lifetime of the UV cell corresponds to approx. 10,000 hours at a maximum of +50°C; higher ambient temperatures reduce the lifetime considerably. For details, refer to chapter *Technical Data* in Data Sheet N7712 for the QRA2/QRA10. For details, refer to chapter *Technical Data* in Data Sheet N7711 for the QRA4.

## Technical data (continued)

Flame supervision with photocell detector RAR9	At mains voltage	
	120 V AC	230 V AC
Values apply to factory setting of parameters 182 = 0		
Switching threshold (limit values):		
• Switching on (flame ON)	≥6.5 µA DC	≥6.5 µA DC
• Switching off (flame OFF)	≤3.5 µA DC	≤3.5 µA DC
Detector current required for reliable operation	≥10 µA DC	≥10 µA DC
Switching threshold in the event of poor flame during operation (LED flashes green)	Approx. 10 µA DC	Approx. 10 µA DC
Possible detector current with flame (typical)	65 µA DC	65 µA DC
Possible detector current in the event of glare, e.g., with artificial light (leads to lockout with error message Loc: 10)	70 µA DC	70 µA DC

The detector current values specified in the table only apply to the factory settings and under the following conditions:

- Mains voltage 120 V AC / 60 Hz or 230 V AC / 50 Hz, depending on type
- Ambient temperature 23 °C
- Parameter 182 in accordance with the factory setting from the following table

Range adjustment for flame sensitivity using parameter 182:	Switching threshold for switching on flame ON signal / Test level switching threshold for flame detector		
	ION	QRA2 / QRA2M / QRA4 / QRA4M / QRA10 / QRA10M	RAR9
Parameter 182 = 0	<b>1 µA / 1 µA <sup>1)</sup></b>	<b>12 µA / 12 µA <sup>1)</sup></b>	<b>5 µA / 5 µA <sup>1)</sup></b>
Parameter 182 = 1	2 µA / 2 µA	12 µA / 12 µA	10 µA / 8 µA
Parameter 182 = 2	4 µA / 4 µA	12 µA / 12 µA	20 µA / 18 µA
Parameter 182 = 3	8 µA / 8 µA	12 µA / 12 µA	30 µA / 28 µA

<sup>1)</sup> Values printed in bold are the same as the factory settings.

**Technical data (continued)**

LFS1.2 terminal 7  
voltage output for flame  
supervision with  
ionization probe

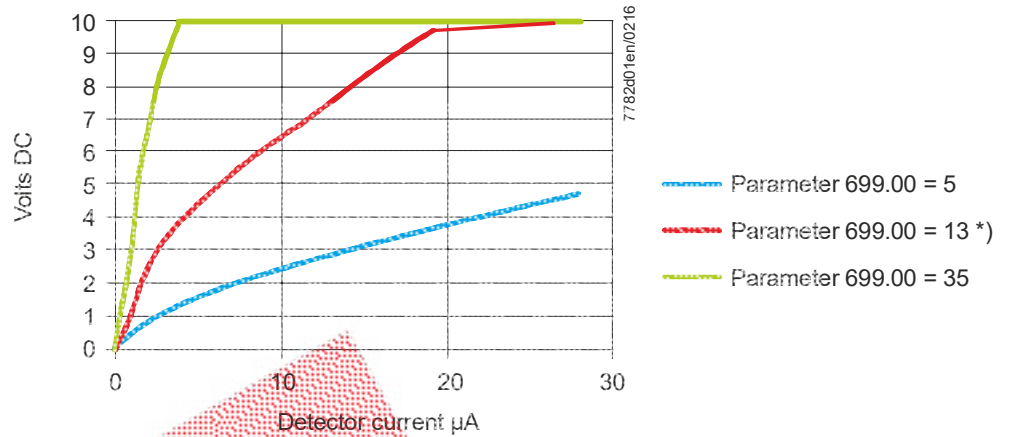

\*) Factory setting

LFS1.2 terminal 7  
voltage output for flame  
supervision with QRA2/  
QRA2M / QRA4 /  
QRA4M / QRA10 /  
QRA10M

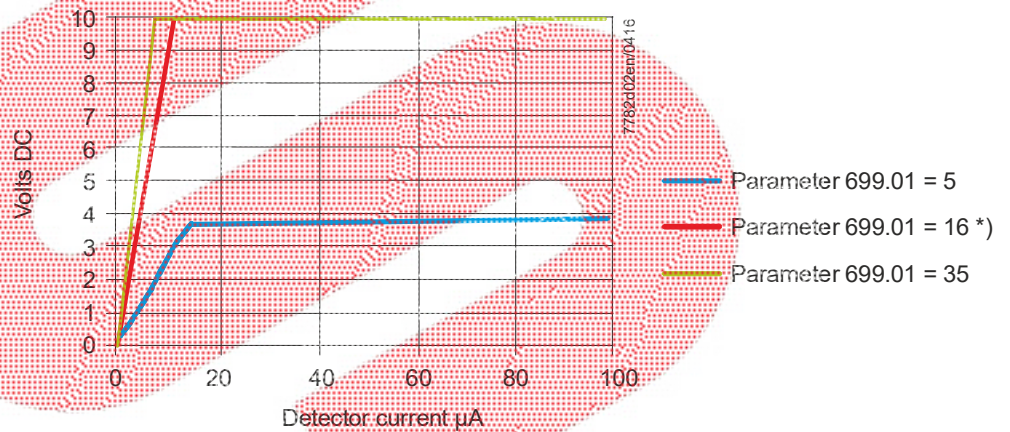

\*) Factory setting

LFS1.1 terminal 7  
voltage output for flame  
supervision with RAR9

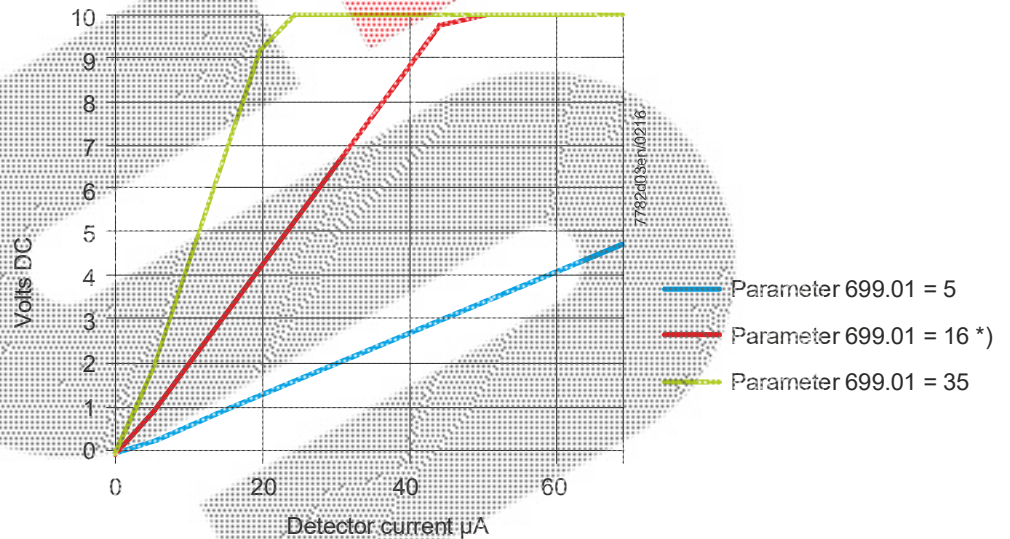

\*) Factory setting

The information applies under the following conditions:

- Mains voltage 230 V AC / 50 Hz or 120 V AC / 60 Hz, depending on type
- Ambient temperature 23 °C

**Connection diagram and internal diagram**

LFS1.1 with RAR9

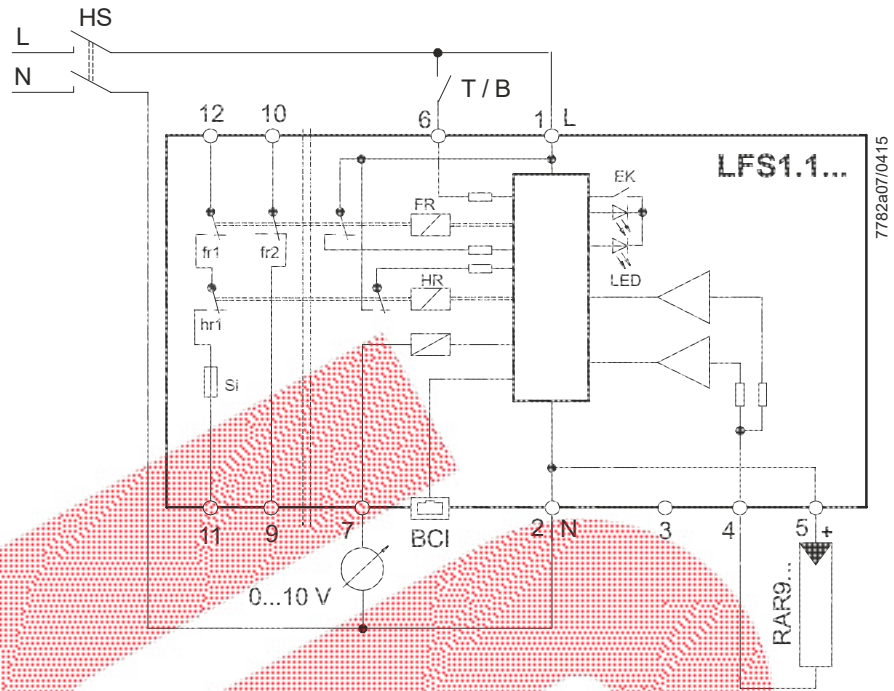

**Note!**  
 The test mode switchover (T/B) is only required in conjunction with the control unit LEC1. Otherwise terminal 6 of the LFS1 must be connected directly to the phase conductor «L» at terminal 1 in this case.

**Key**

BCI	Communication interface (Burner Communication Interface)	HS	All-polar main switch
EK	Lockout reset button (internal)	ION	Ionization probe
FS	Flame signal	LED	internal LED (three-colored)
FSV	Flame signal amplifier	QRA	UV flame detector
FR	Internal flame relay	RAR9	Photocell detector
fr1	Flame relay NO contact	Si	Internal fuse
fr2	Flame relay NC contact	T/B	Flame signal amplifier test mode switchover (QRA, RAR9: Only required in case of replacement by LEC1)
HR	Internal auxiliary relay (test mode switchover)	0...10 V	Voltage output for outputting flame signal strength
hr1	Auxiliary relay NO contact	+	Terminal labeling on QRA

# Connection diagram and internal diagram

LFS1.2 with QRA2 / QRA4 / QRA4M / QRA10

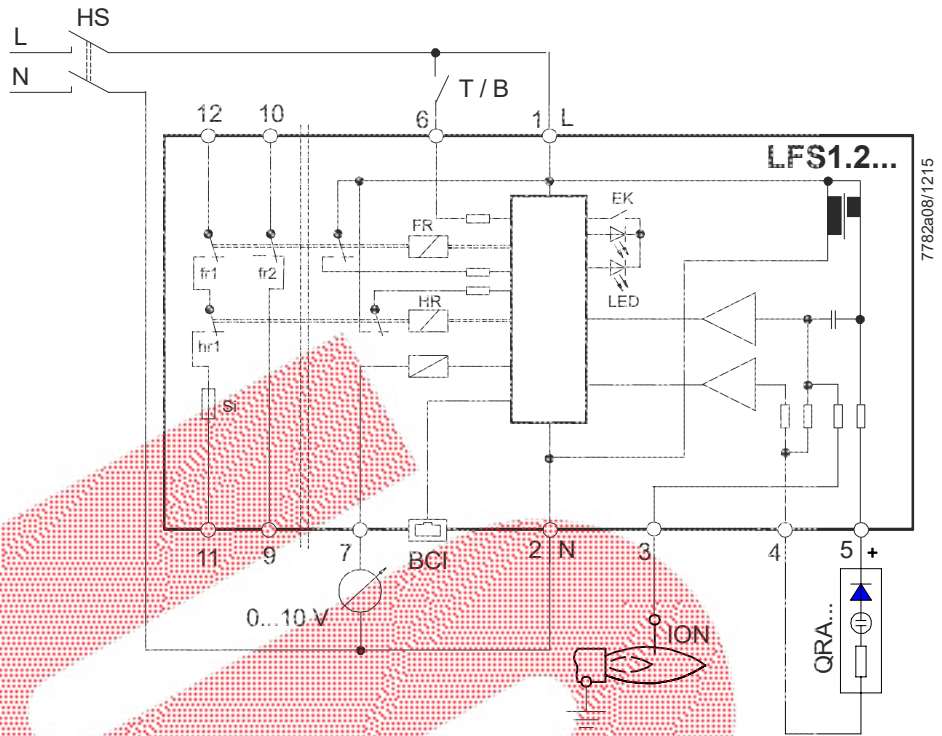

## Key

BCI	Communication interface (Burner Communication Interface)	HS	All-polar main switch
EK	Lockout reset button (internal)	ION	Ionization probe
FS	Flame signal	LED	Internal LED (three-colored)
FSV	Flame signal amplifier	QRA	UV flame detector
FR	Internal flame relay	RAR9	Photocell detector
fr1	Flame relay NO contact	Si	Internal fuse
fr2	Flame relay NC contact	T/B	Flame signal amplifier test mode switchover (QRA, RAR9: Only required in case of replacement by LEC1)
HR	Internal auxiliary relay (test mode switchover)	0...10 V	Voltage output for outputting flame signal strength
hr1	Auxiliary relay NO contact	+	Terminal labeling on QRA

**Connection diagram and internal diagram**

LFS1.2 with QRA2M / QRA10M

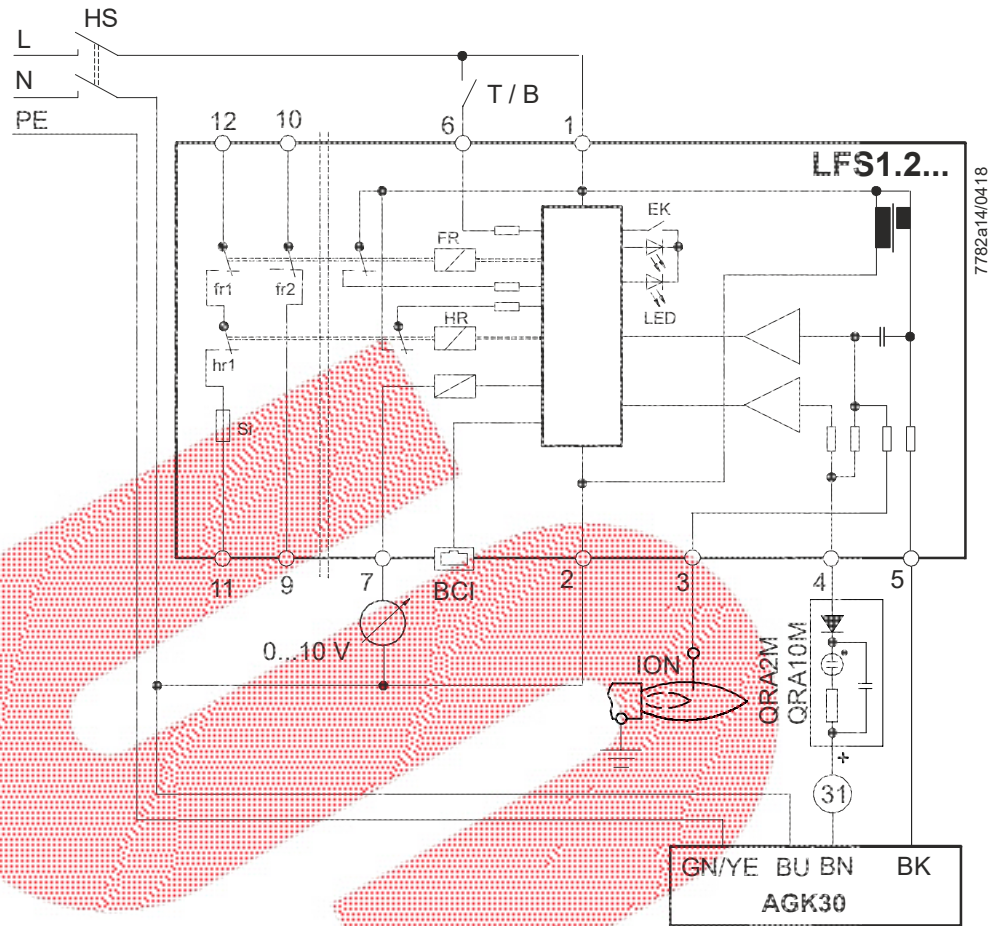

7782a14/0418

**Key**

BCI	Communication interface <b>(Burner Communication Interface)</b>	HS	All-polar main switch
EK	Lockout reset button (internal)	ION	ionization probe
FR	Internal flame relay	LED	internal LED (three-colored)
fr1	Flame relay NO contact	QRA	UV flame detector
fr2	Flame relay NC contact	Si	Internal fuse
HR	Internal auxiliary relay (test mode switchover)	T/B	Flame signal amplifier test mode switchover (QRA, RAR9: only required when replacing with LEC1)
hr1	Auxiliary relay NO contact	0...10 V	Voltage output for outputting flame signal strength
1...31	Number of terminals in plug-in base AGK11.7	+	Terminal marking on QRA

**Connecting wire colors of AGK30**

BU	Blue
BN	Brown
GN/YE	Green/yellow
BK	Black

# LFS1 program sequence

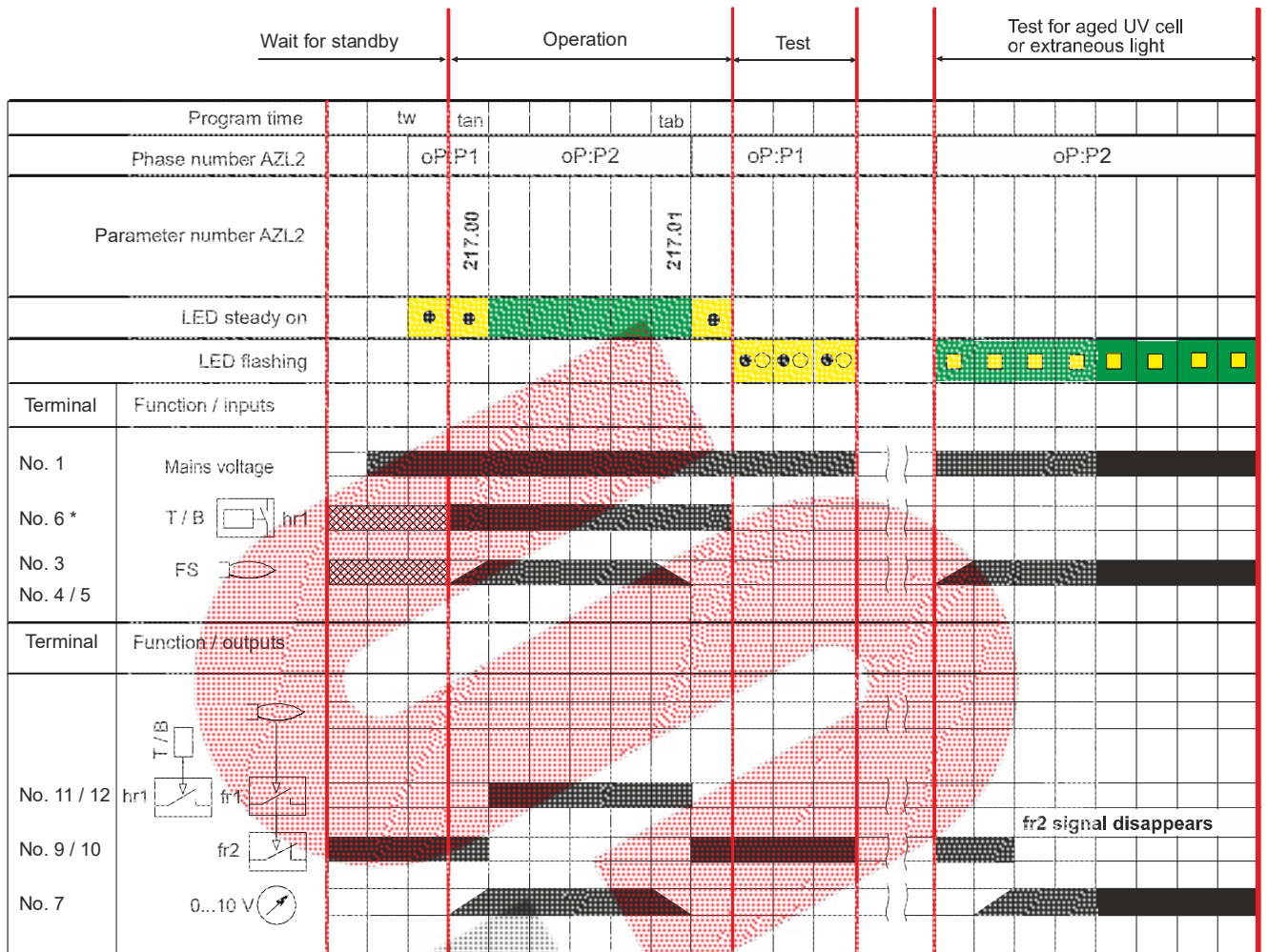

7782d08en/0718

## Key

FS	Flame signal	tw	Waiting time
fr1	Flame relay NO contact	tan	Flame signal flame-on response time
fr2	Flame relay NC contact	tab	Flame signal flame-out response time
hr1	Auxiliary relay NO contact	0...10 V	Voltage output for outputting flame signal strength
LED	Internal LED (three-colored)	oP:P1	Flame signal OFF
T/B	Flame signal amplifier test mode switchover (QRA2 / QRA2M / QRA4 / QRA4M / QRA10 / QRA10M)	oP:P2	Flame signal ON
*	Extraneous light test for flame detectors QRA (not required for RAR9 and ionization probe flame supervision)		Input / output signal 1 (ON)
			Input / output signal 0 (OFF)
			Input permissible signal 1 (ON) or 0 (OFF)

### Basic mode of operation of the flame safeguards in conjunction with control unit LEC1.

When used with the LEC1, the flame safeguard feeds the flame signal into the burner control's control program in essentially the same way as if the flame safeguard were a component of the burner control (as in the case of an oil or gas burner control). In the event of non-ignition, loss of flame during burner operation, or a faulty flame signal during burner off or purging times, the burner will always be shut down and the burner control will initiate lockout. The switching functions needed to feed the flame signal into the burner control's control circuit are provided by the flame relay (FR) of the flame safeguard and the 2 auxiliary relays (HR1 / HR2) of the control unit LEC1; refer to Data Sheet N7761. In conjunction with the flame safeguard LFS1, the control unit LEC1 provides the sequence control for the flame simulation test and the flame detector test on the LFS1. The test is controlled via the connecting line between terminal 15 of the control unit LEC1 and terminal 6 of the flame safeguard LFS1.

#### Both tests

- start about 7 seconds after a controlled shutdown
- are continued during burner off periods
- are continued during the ensuing prepurge time
- end 3 seconds before the start of the safety time

The following flame signals during this test time lead to lockout with interlocking of the control unit LEC1:

- Extraneous light
- Aging flame detectors
- Other defects in the flame supervision equipment

In the flame safeguard, the switching functions required for testing are performed by the auxiliary relay (HR). Since it is not necessary to carry out a test in the case of flame supervision with an ionization probe, the connecting line between terminal 15 of the burner control and terminal 6 of the flame safeguard is not required here. Instead, terminal 6 must be connected to the phase.

#### Example:

*By making a connection to terminal 1 of the LEC1*

Any flame signal – be it a normal flame signal during operation or a faulty signal – is indicated by the signal lamp (3-colored LED) in the housing of the flame safeguard; refer to *Indication and diagnostics* chapter.

**Mode of operation of the flame safeguards with dual supervision (detailed connection diagram, e.g., for oil burners)**

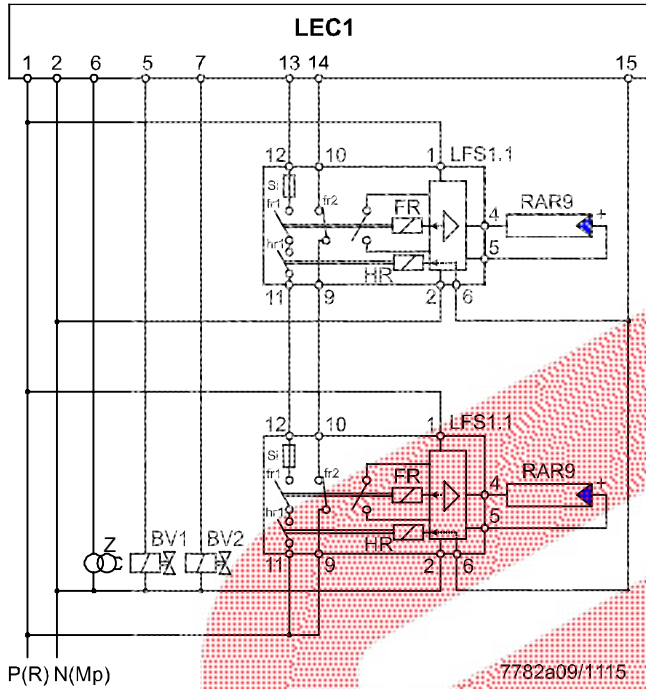

With this type of supervision, **1** flame is supervised by **2** independently operating flame safeguards. The aim is to reduce the possibility of loss of flame during operation, in the case of a simultaneous failure of **both** flame safeguards, to an *unlikely coincidence*. With dual supervision, the control contacts of the flame relays of both flame safeguards are connected in series so that loss of the **flame signal of either of the flame safeguards is sufficient** to cause lockout of the burner. A faulty flame signal by only **1** of the 2 flame safeguards during burner off times or purging times also leads to lockout.

- Key
- FR Internal flame relay
  - fr1 Flame relay NO contact
  - fr2 Flame relay NC contact
  - HR Internal auxiliary relay (test mode switchover)
  - hr1 Auxiliary relay NO contact
  - BV1 1st fuel valve
  - BV2 2nd fuel valve
  - RAR9 Photocell detector
  - Si Internal fuse
  - Z Ignition transformer

## Mode of operation of the flame safeguards when used for the supervision of 2 manually controlled burners

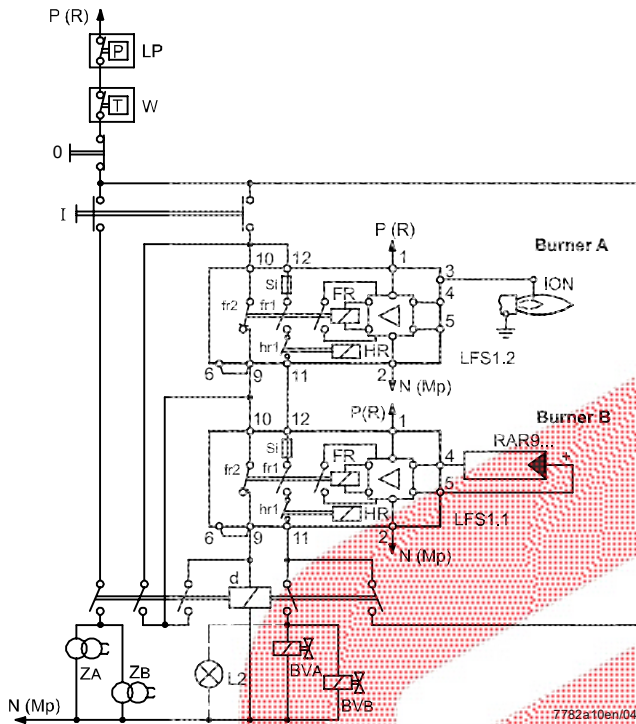

With this type of supervision, too, the burner can be started only if the flame detector test or flame simulation test has been successful. This means that **neither** of the 2 flame safeguards may detect a flame signal during burner off times. When the burner is started up, the detector test will automatically be interrupted. When button (I) is pressed, relay (d) is energized via circuit path 9...10 of the flame relays, which is still closed, thus switching on the ignition of both burners. At the same time, fuel is released. The duration of the start pulse given by pressing button (i) should be limited by a time relay – in the sense of a **safety time**. If a flame is established on **both** burners – indicated by the signal lamps in the housing of the flame safeguards – relay (d) is now maintained in its energized condition via circuit path 11...12 of the 2 flame relays. When the button (I) is released, the ignition will be switched off, thus completing the startup sequence. If the event of loss of flame on 1 of the burners, the respective flame relay is deenergized, thereby neutralizing the holding circuit for relay (d). This means that the fuel valves of **both** burners will immediately be shut. The burners are switched off manually by pressing the button (0), or automatically by the control thermostat or pressurestat / pressure switch in the phase wire connection. In the case of flame supervision with ionization probes, terminal 6 of the flame safeguards must be connected directly to the phase since no detector test is required here.

### Example:

With a connection to terminal 1.



### Note!

Ensure that the drop-out delay time of relay **d** does not exceed 50 ms; refer to connection example 7782a06.

Key	
BVx	Fuel valve
FR	Internal flame relay
fr1	Flame relay NO contact
fr2	Flame relay NC contact
HR	Internal auxiliary relay (test mode switchover)
hr1	Auxiliary relay NO contact
L2	Lockout warning lamp, external
LP	Air pressure switch
Rx	Control thermostat or pressurestat
Si	Internal fuse
W	Limit thermostat or pressure switch
Z	ignition transformer

**Mode of operation of the flame safeguards in the case of multiflame supervision with LEC1 (detailed connection diagram, e.g., for gas burners)**

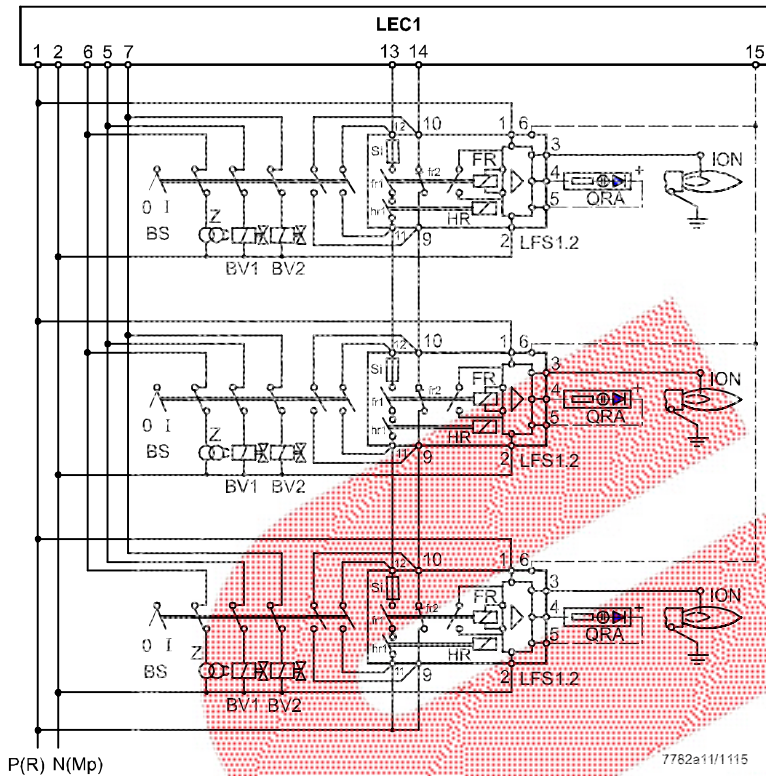

As with dual supervision, the control contacts of the flame relays of all flame safeguards must be connected in series in the case of multiflame supervision.

A burner causes all other burners to go to lockout if:

- The flame is not established during the safety time, or
- The flame is lost during operation.

After the burner control has been reset, correctly operating burners can only be restarted once the faulty burner has been shut down. In that case, the operating switch must not only bridge the control contacts of the relevant flame safeguard, thus closing the control chain again, but must also break the phase wire connection to the ignition transformer and the fuel valves. Likewise, after rectification of the error, the burner can only be restarted together with the other burners; that is, only after all burners have previously been shut down.

**Attention!**



An ignited UV tube is a **source of UV radiation**. In the case of flame supervision by means of flame detectors, the detectors must be placed in a way that ensures there is **no direct visual contact** between them. If this is not observed, there is a risk of loss of safety functions.

**Attention!**



When replacing the LFE10 with the LFS1.2, the earth connection at terminal 10 in the LFE10 terminal base must be removed: terminal 5 of the LFS1.2 must not have an earth connection. Earth connection of QRA10 remains unchanged to ensure the protection class 1.

**Key**

BS	Operating switch: OFF / ON → for each burner
FR	Internal flame relay
BV1 / BV2	Fuel valves for 1st and 2nd stage
fr1	Flame relay NO contact
fr2	Flame relay NC contact
HR	Internal auxiliary relay (test mode switchover)
hr1	Auxiliary relay NO contact
ION	Ionization probe
QRA	UV flame detector
Si	Internal fuse
Z	Ignition transformer

# Mode of operation of the flame safeguards in the case of multiflame supervision with a PLC, intermittent operating mode

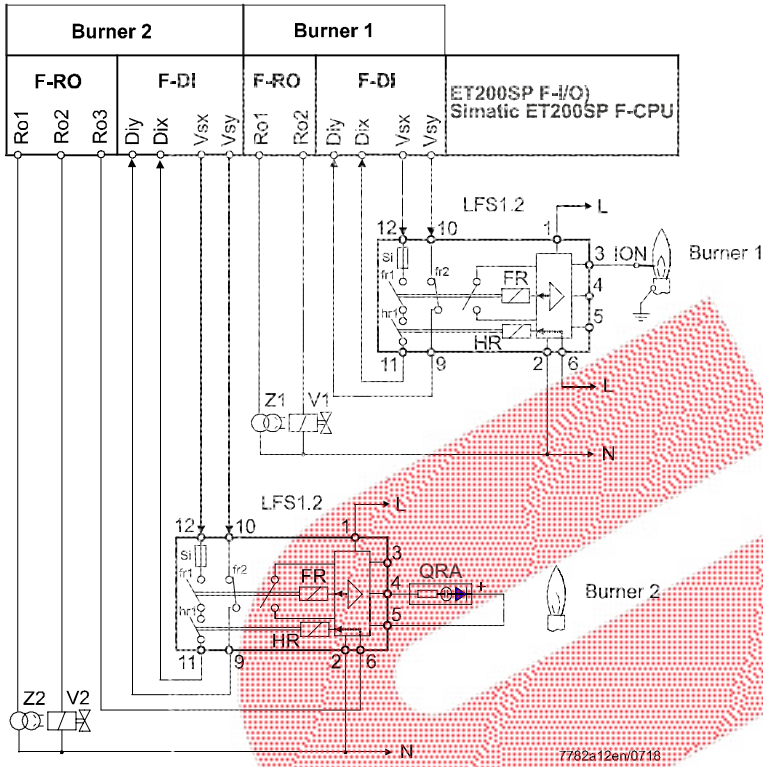

In the case of multiflame supervision, a fail-safe PLC performs the central control function (the example shown uses a Simatic ET200SP F-CPU and input / output modules ET200SP F-I/O). Each burner has its own ignition equipment, its own fuel valve, and its own flame supervision system (made up of a flame safeguard LFS1.2 and a flame detector). The control contacts for all the flame safeguards' flame relays are connected in parallel. In other words, each burner can be switched on and off independently of the other burner. The flame signal is evaluated in the PLC on a non-equivalent basis in line with the evaluation principle 1oo2 (1-OFF-2). This means that the 2-way start pulse is tested at terminals **Dix** and **Diy**. In the event of a flame ON signal, the fr1 (NO) contact closes and the fr2 (NC) contact opens at the same time. In the event of a flame OFF signal, the fr2 (NC) contact closes and the fr1 (NO) contact opens at the same time.

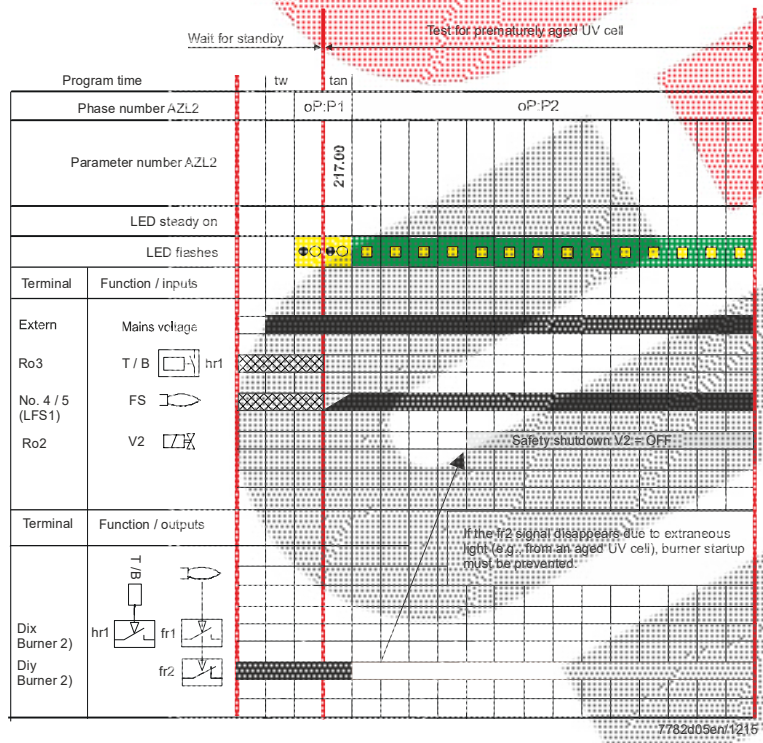

The test mode switchover for the burner 1 flame safeguard is inactive (terminal 6 is permanently connected to phase conductor "L"). The test mode switchover for the burner 2 flame safeguard is active. This means that terminal 6 is switched off by the PLC via a fail-safe relay output (Ro3) at set intervals or after 24 hours of uninterrupted burner operation at the very latest; refer to the adjacent control sequence. The PLC must prevent further burner operation until the cause of the error has been rectified.

**Mode of operation of the flame safeguards in the case of multiflame supervision with pilot burner and a PLC, intermittent operating mode**

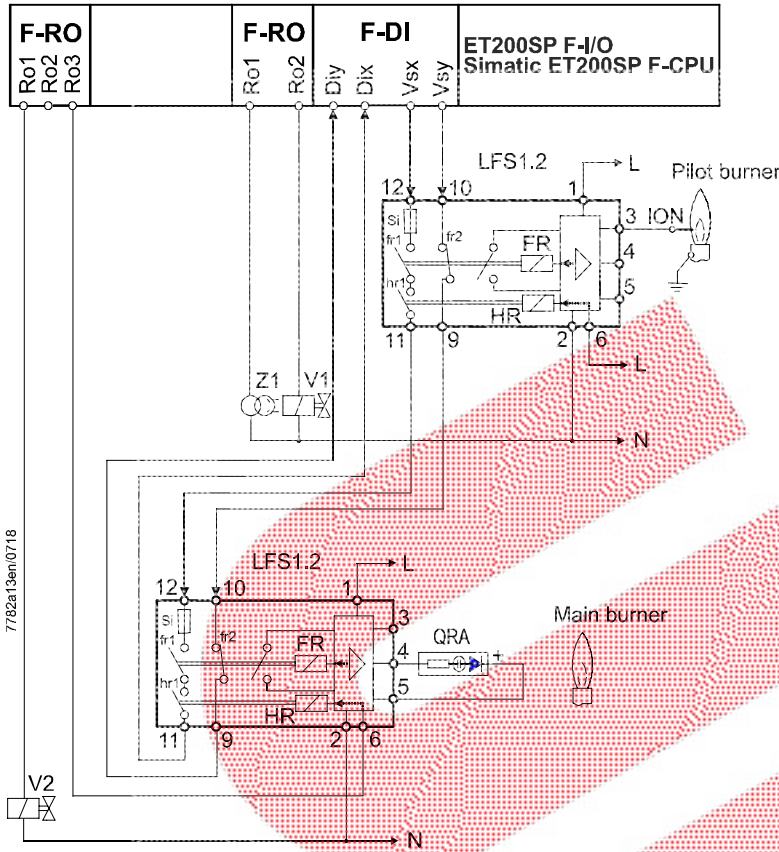

In the case multiflame supervision with a pilot burner, a fail-safe PLC performs the central control function (the example shown uses a Simatic ET200SP F-CPU and input / output modules ET200SP F-I/O). The pilot burner has its own ignition equipment (Z1), its own fuel valve (V1), and its own flame supervision system made up of a flame safeguard LFS1.2 and an ionization probe (ION). The main burner has its own fuel valve (V2) and its own flame supervision system made up of a flame safeguard LFS1 and a UV flame detector QRA. The main burner does not have its own ignition equipment (Z1) as its flame is safely ignited by the pilot burner. The flame relay control contacts for both flame safeguards LFS1.2 are connected in series. This means that both burners can only be switched on and off together with the other burner in each case. The flame ON signal at terminals **Dix / Diy** on the digital input module F-DI can therefore only occur when both flame signals are present. Extinguishing 1 of the 2 flames, or even both flames, leads to a flame OFF signal. The flame signal is evaluated in the PLC on a non-equivalent basis in line with the evaluation principle 1oo2 (1-OFF-2). This means that the 2-way start pulse is tested at terminals *Dix* and *Diy*. In the event of a flame ON signal, the fr1 (NO) contact closes and the fr2 (NC) contact opens at the same time. In the event of a flame OFF signal, the fr2 (NC) contact closes and the fr1 (NO) contact opens at the same time.

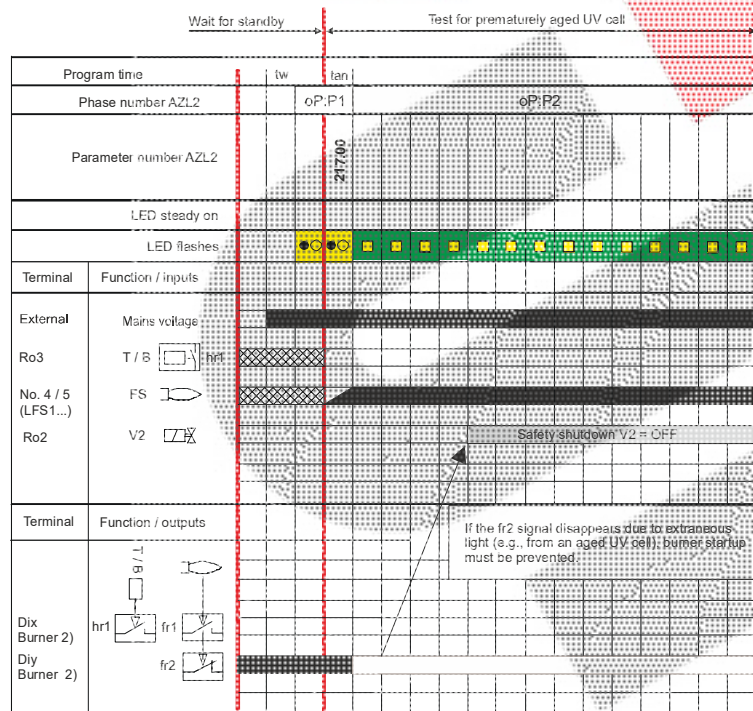

The test mode switchover for the pilot burner flame safeguard is inactive (terminal 6 is permanently connected to phase conductor "L"). The test mode switchover for the main burner flame safeguard is active. This means terminal 6 is switched off by the PLC via a fail-safe relay output (Ro3) at set intervals or after 24 hours of uninterrupted burner operation at the very latest; refer to the adjacent control sequence. The PLC must prevent further burner operation until the cause of the error has been rectified.



**Attention!**

A fail-safe PLC must be used!

Key

F-CPU	Fail-safe CPU (central processing unit) of PLC
F-DI	PLC fail-safe digital input modules
F-RO	PLC fail-safe digital relay output modules
ION	ionization probe
L / N	Phase conductor / neutral conductor
FR / HR	Flame relay / auxiliary relay
V1 / V2	Fuel valve for burner 1 / burner 2
QRA	UV flame detector
PLC	Programmable logic controller
Z1	Ignition transformer for pilot burner

Operation

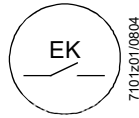

The lockout reset button (EK) is the key operating element for resetting the burner control and for activating / deactivating the diagnostics functions.

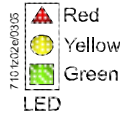

The multicolor signal lamp (LED) in the lockout reset button is the key indicating element for both visual diagnostics and interface diagnostics.

Both elements (EK / LED) are located under the transparent cover of the lockout reset button.

There are 2 diagnostics options:

1. Visual diagnostics: Operational status indication or diagnostics of the cause of error.
2. Interface diagnostics: With the help of interface adapter OCI400 and PC software ACS410 (in preparation).

A description of the visual diagnostics is provided below.

Operational status indication

In normal operation, the different operating states are indicated in the form of color codes according to the color code table below:

Color code table for the multicolor signal lamp (LED)

Status	Color code	Color
Waiting time (tw) or no operating voltage		OFF
Waiting for flame signal		Yellow
Test mode active, no extraneous light signal available		Flashing yellow
Test mode active, extraneous light signal available		Yellow-green
Operation, flame OK		Green
Operation, flame not OK		Flashing green
Undervoltage		Yellow-red
Error, alarm		Red
Error code output; refer to Error code table		Flashing red
Interface diagnostics		Red flickering light
Warning message: 1 million switching cycles exceeded (switching cycle counter)		Also flashes yellow in addition to the current color "x"

Key

- ..... Permanent
- OFF



Service counter

Press the lockout reset button (EK) for 10 seconds to activate a yellow flashing warning signal when 1 million switching cycles have been performed. In this case, it is advisable to carry out a safety test or to replace the unit. If 1 million switching cycles have not yet been performed, there will be no yellow flashing warning signal. Press the lockout reset button (EK) for 10 seconds again to deactivate this function.

Diagnostics of cause of error

After lockout, the red signal lamp (LED) lights up. In this status, visual diagnostics of the cause of the error according to the error code table can be activated by pressing the lockout reset button for more than 3 seconds. By pressing the lockout reset button again for more than 3 seconds, the interface diagnostics will be activated. The interface diagnostics only work if the AGK20 lockout reset button extension is not fitted. If the interface diagnostics have been activated by accident – in which case the slightly red light of the signal lamp (LED) flickers – it can be deactivated by pressing the lockout reset button again for more than 3 seconds. The moment of switching over is indicated by a yellow light pulse.

The following sequence activates diagnostics of the cause of the error:

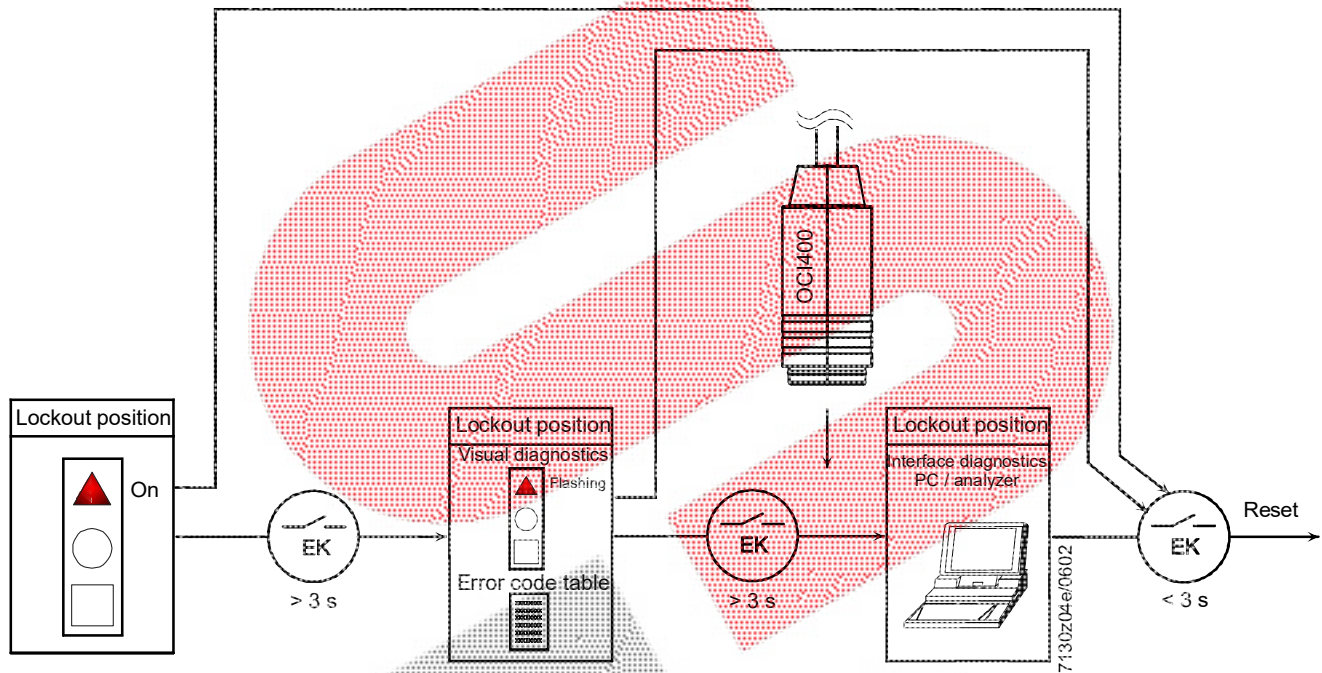

Signal lamp (LED) flashing code	Possible cause
1...9 flashes	Free
10 flashes	Wiring error or internal error, output contact error, other errors. Flame detector RAR9 current outside permissible range (defective flame detector RAR9 or glare). Short circuit at the connection terminals of the UV flame detectors QRA at the operating level (terminal 6 of the LFS1 active)
15 flashes	Manual locking active (Loc: 167)

When diagnosing the cause of errors, the built-in relays **FR** and **HR** are in the no-load position.

Reset to quit the diagnostics of the cause of the error and switch the flame safeguard on again. Press the lockout reset button for about 1 second (less than 3 seconds).

BC interface

The BC interface connection jacks are located on the underside in the LFS1 base area; refer to the figure. Parameters can be set in accordance with the parameter list below using the display and operating unit AZL2 and signal cable AGV50. The signal cable AGV50 is preassembled and fitted with a RJ11 connector. When connecting, ensure that the orientation is correct – the clip on the RJ11 connector must be inserted into the notch on the connection jack. A click sound indicates that the clip has locked into place. To disconnect the connection, open the clip by gently tilting it towards the cable using your finger before pulling out the RJ11 connector.

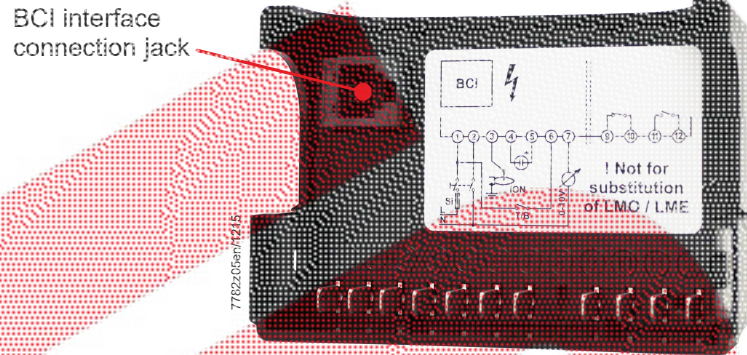

The display and operating unit AZL2 with LCD display enables simple operation, parameterization, and targeted diagnostics via menu-driven operation. When performing diagnostics, the display shows the operating statuses, the type of error, and the startup counter (IBZ). Passwords protect the different parameter levels for OEM (burner / boiler manufacturer) and heating engineers (HF) against unauthorized access. Simple settings that the plant operator can make on site do not require a password.

For detailed information on parameterization, refer to User Documentation A7782, *Operation via AZL2* chapter.

# Dimensions

Dimensions in mm

LFS1



Plug-in base AGK11.7 and AGK65.1

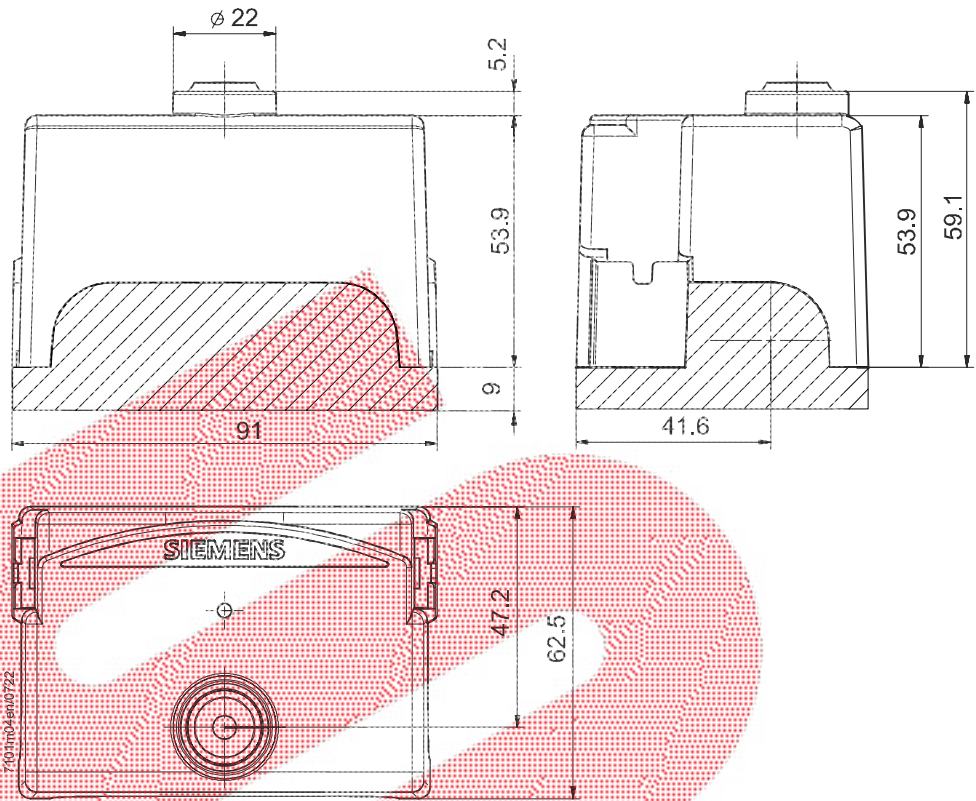

Plug-in base AGK11.7 with separating plate element (D)



AGK11.7 plug-in base

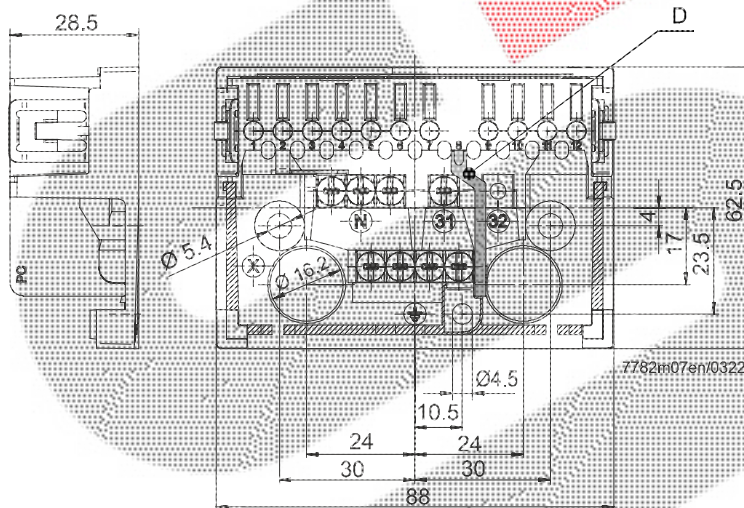

Dimensions (continued)

Dimensions in mm

Adapter KF8896

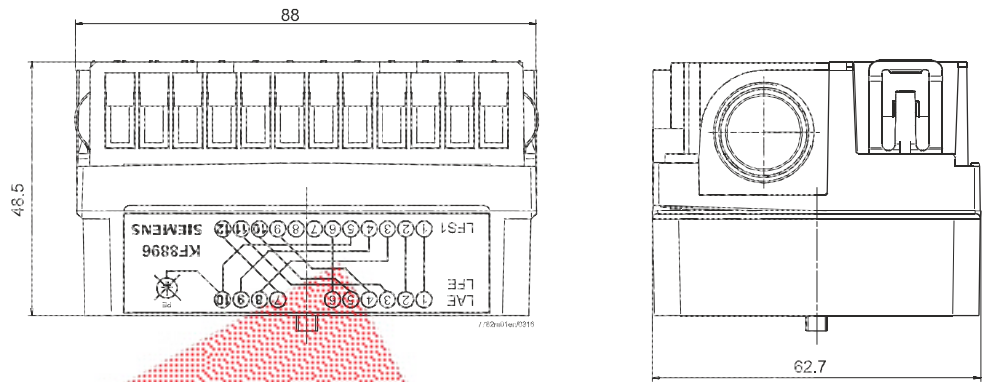

When replacing LAE10 and LFE10 with LFS1, adapter KF8896 ensures that the height can be adjusted mechanically and that the terminals are assigned correctly.

LFS1 with adapter KF8896 and plug-in base for LAE10 / low plug-in base for LFE10 AGK410413450

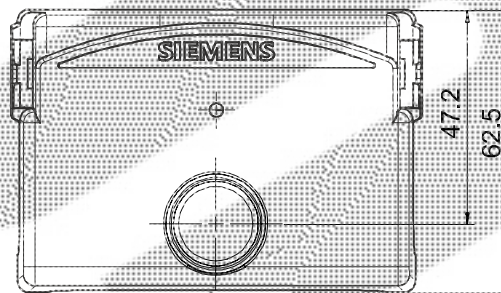
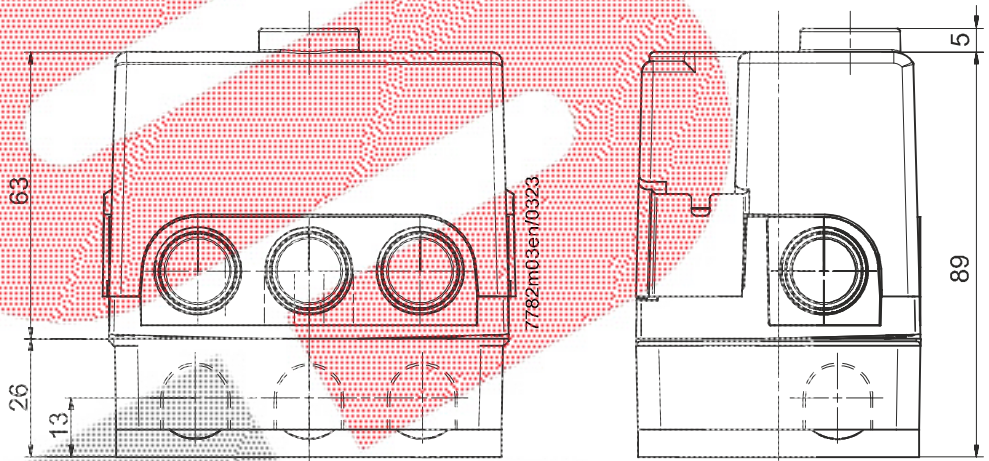

## Dimensions (continued)

Dimensions in mm

LFS1 with adapter KF8896  
and plug-in base for LAE10 /  
high plug-in base for LFE10  
AGK410490250

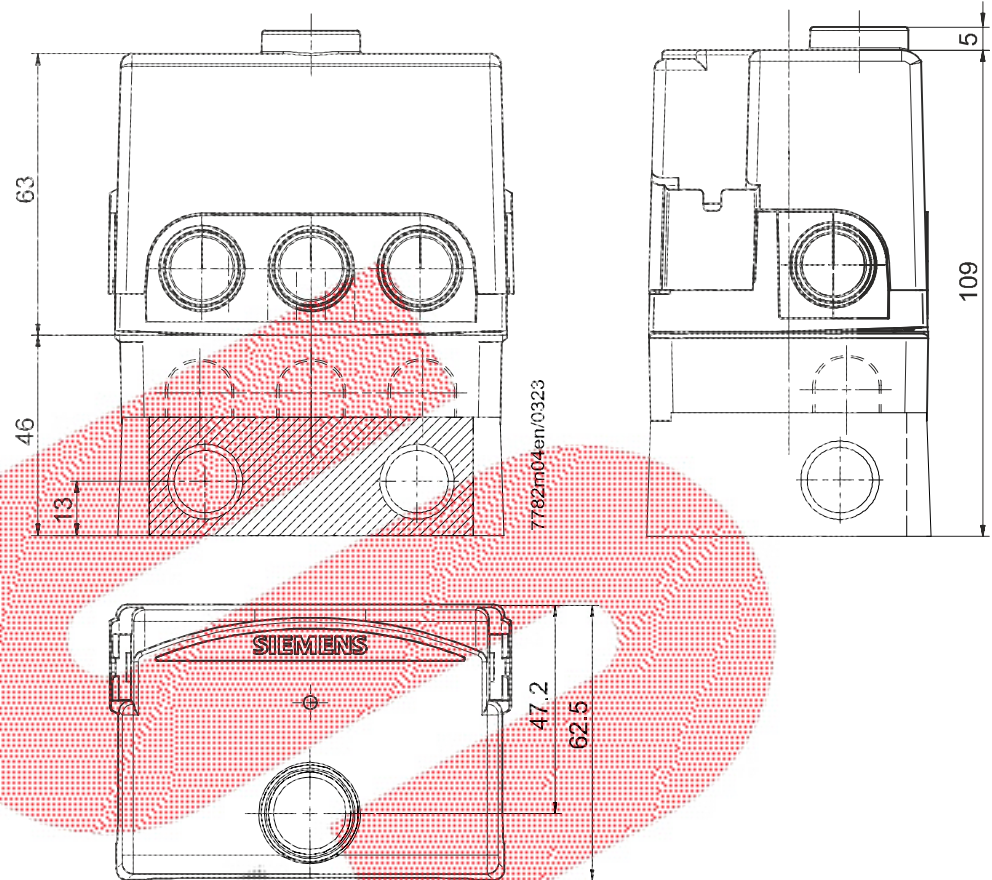

**Dimensions (continued)**

Dimensions in mm

LFS1 with lockout reset  
button extension  
AGK20

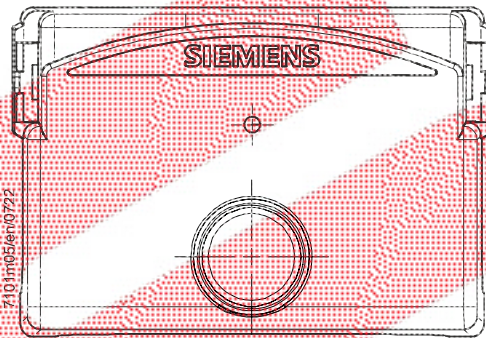
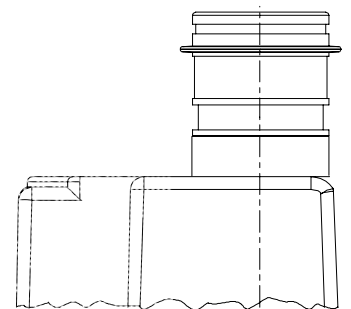
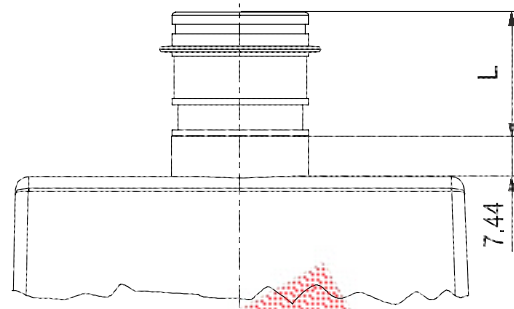

Designation	Length (L) in mm
AGK20.19	19
AGK20.43	43
AGK20.55	55