

BNM, BNM4 (close-coupled bronze version)

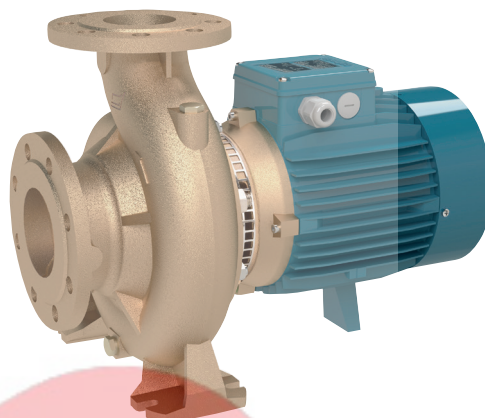

NM, NM4 (close-coupled cast iron version)

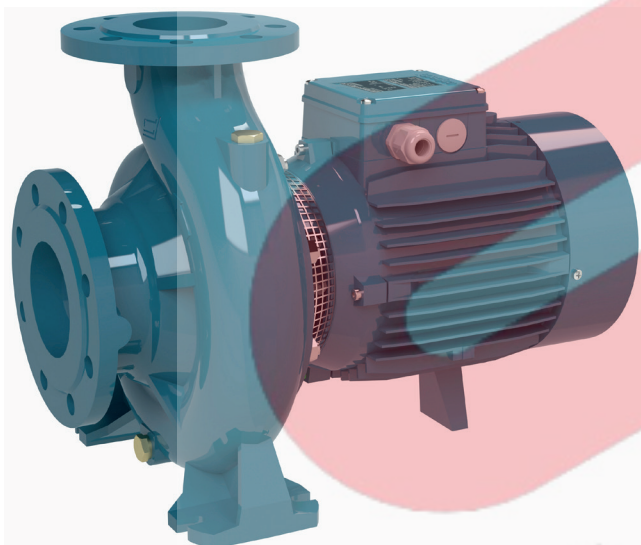

NM EI, NM4 EI (close-coupled with I-MAT version)

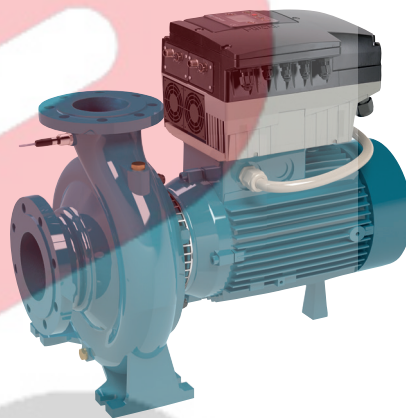

NMS, NMS4 (Stub-shaft cast iron version)

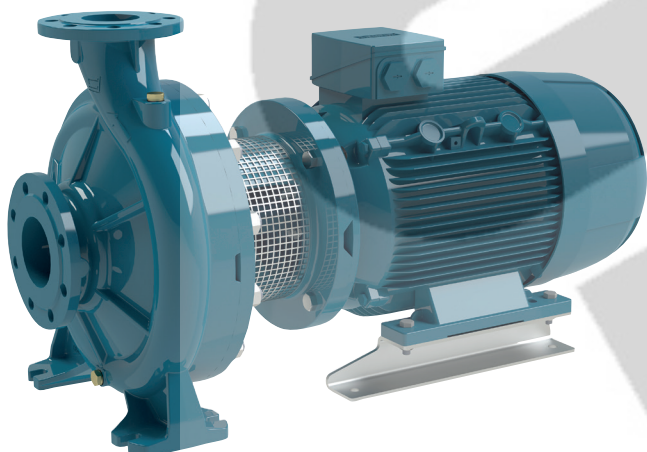

BNMS, BNMS4 (Stub-shaft bronze version)

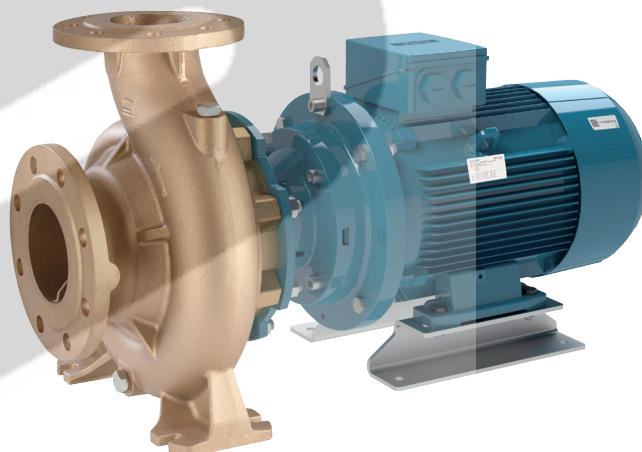

Close coupled centrifugal pumps with flanged connections

## Construction

NM, NM4 Close-coupled centrifugal pumps; electric motor with extended shaft directly connected to the pump up to 22 kW (15 kW for NM4).

NMS, NMS4 Close-coupled centrifugal pumps, new bracket construction for standard motors (stub-shaft construction) with integrated thrust bearing.

Rated speed of rotation (50 Hz):  
 NM, NMS ≈ 2900 rpm.  
 NM4, NMS4 ≈ 1450 rpm.

Pump casing with axial suction and radial delivery on top, main dimensions and performance according to EN 733 with additional sizes for completion. (NMS4 80/400).

**NM(S), NM(S)4:** version with pump casing and lantern bracket in cast iron.

**BNM(S), BNM(S)4:** version with pump casing and lantern bracket/casing cover in bronze.

The pumps are supplied fully painted.

### Version with frequency converter (on request)

**Connections:** Flanges PN 10-16, EN 1092-2 (PN 10 for DN 200)

### Counter-flanges (on request)

Sizes	Flanges
from NM, NM4 32/.. to NM, NM4 50/..	Screwed flanges EN 1092-1, PN 16
from NM, NM4 65/.. to NMS4 150/..	Flanges for welding EN 1092-1, PN 10-16 (PN 10 for DN 200)

## Applications

For clean liquids without abrasives, which are non-aggressive for the pump materials (solids content up to 0.2%).

For water supply.

For heating, air-conditioning, cooling and circulation plants.

For civil and industrial applications.

For irrigation.

## Operating conditions

Liquid temperature from -10 °C to +90 °C.

Ambient temperature up to 40° C.

Total suction lift up to 7 m.

Maximum permissible working pressure up to 16 bar (10 bar for NM 32/12; NM, NM4 32/16,20; NM, NM4 40/25; NM, NM4 50/20,25; NM4 65/31; NM, NM4 100/25; NM4 100/315,400; NM4 125/250 and bronze version).

Continuous duty.

## Materials

Components	NM, NM4, NMS, NMS4	BNM, BNM4, BNMS, BNMS4
Pump casing	Cast iron GJL 250 EN 1561 for PN 10 Cast iron GJS 400-15 EN 1563 for PN 16	Bronze CC480K EN 1982
Lantern bracket NM	Cast iron GJL 200 EN 1561	Bronze CC480K EN 1982
Casing cover for NMS(4)	Cast iron GJL 200 EN 1561	Bronze CC480K EN 1982
Lantern bracket NMS(4)	Cast iron GJL 200 EN 1561	Cast iron GJL 200 EN 1561
Impeller	Cast iron GJL 200 EN 1561	Bronze CC480K EN 1982
	Cast iron GJL 250 EN 1561 For ..80/315,400; 100/315,400; 125/315,400; 150/315,400	
	Brass CW617N EN 12167 For .. 32/12-16-20, .. NM 40/20	
Shaft	Chrome-nickel steel 1.4305 EN 10088 (AISI 303)	Steel 1.4401 EN 10088 (AISI 316)
	Steel 1.4104 EN 10088 (AISI 430F) from 3kW to 75kW	Steel 1.4401 EN 10088 (AISI 316)
	Steel 1.4462 EN 10088 (AISI 2205) for NMS4150/400S	Steel 1.4462 EN 10088 (AISI 2205) for BNMS4150/400S
Mechanical seal	Carbon - Ceramic - NBR	Carbon - Ceramic - NBR
Counter-flanges	Steel 1.0044 EN 10025-2 (Fe 430B)	Steel 1.0044 EN 10025-2 (Fe 430B)

## Motor

2-pole induction motor, 50 Hz (n ≈ 2900 rpm).

**NM, NMS:** three-phase 230/400 V ± 10% up to 3 kW;  
 400/690 V ± 10% from 4 to 75 kW.

4-pole induction motor, 50 Hz (n ≈ 1450 rpm).

**NM4, NMS4:** three-phase 230/400 V ± 10% up to 3 kW;  
 400/690 V ± 10%, from 4 to 90 kW;

Insulation class F.

Protection IP 54 (IP 55 for NMS, NMS4).

Motor suitable for operation with frequency converter.

**Three-phase motors with efficiency class IE2 up to 0.65 kW, IE3 from 0.75 to 55 kW, IE4 from 75 kW.**

Constructed in accordance with: EN 60034-1; EN 60034-30-1.

## Special features on request

Other voltages.

Impeller in chrome-nickel stainless steel for: 32/12, 40/12-16, 50/12-16

Frequency 60 Hz (as per 60 Hz data sheet).

Protection IP 55.

Special mechanical seal

IE4 efficiency class for three-phase motors

Single-phase motor (NMM) up to 1,8 kW.

Higher or lower liquid or ambient temperatures.

## Designation

Example: BNM(S) EI 32/16A/B

B = Bronze version (without Cast Iron version indication)

NM = Series

S = Series Version Stub-Shaft

EI = With frequency converter I-MAT

32 = Delivery port diameter in mm

16 = Nominal impeller diameter

A = Impeller size

/B = It refers to a revision

The electropumps comply with the European Regulation no. 547/2012.

## EI: Pumps with frequency converter

The NM(4) EI pumps are available with power from 0,37 kW up to 37 kW, the pumps are equipped with I-MAT installed on board. Which allows to realize a variable-speed system extremely compact and efficient, ideal in applications of water supply and in the distribution of hot and cold water. The pump is equipped with transducers suitable for operation and is already programmed at the factory.

### Features

- Energy saving
- Compact design
- Easy to use
- Programmable to suit the system requirements
- Reliability

### Construction

The system comprises of:

- Pump
- Induction motor
- I-MAT Frequency converter
- Motor adapter for the motor mounting of the frequency converter
- Connection cable between frequency converter and induction motor
- Single pressure transducer for 2 poles and differential transducer for 4 poles

### Main features

- Rated motor power output from 0,37 kW to 37 kW.
- Control range from 1750 to 2900 rpm (2-pole)
- Control range 870÷1750 1/min (4-pole)
- Protection against dry running
- Protection against operations with closed valve ports
- Protection against system leakages
- Protection against overcurrent in the motor
- Protection against overvoltage and undervoltage of the power supply
- Protection against current unbalances between phases

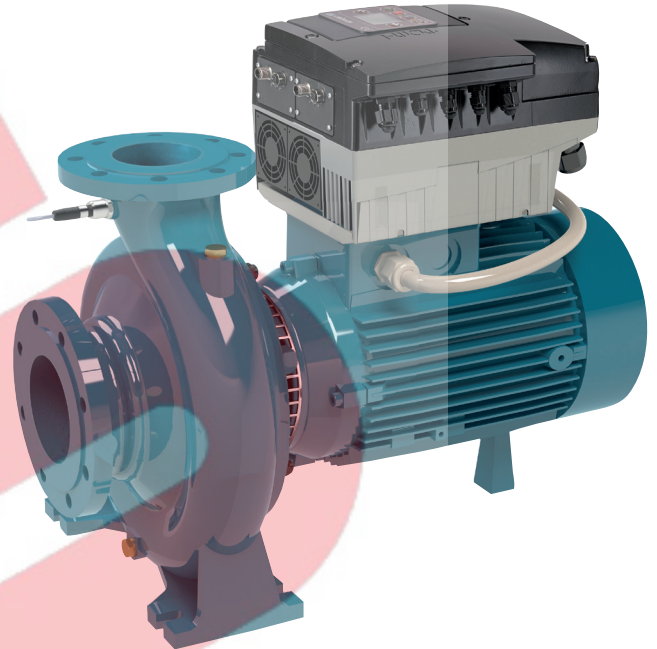

### Operating modes



#### Constant pressure mode

with pressure transducer

In this mode, the system maintains the preset pressure when the flow required by the installation changes.

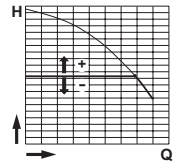

#### Proportional pressure mode

with pressure transducer

In this mode the system changes the working pressure according to the required flow rate.

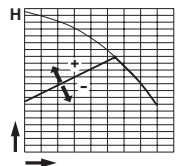

#### Constant flow mode

with flow meter

In this mode the system maintains a constant flow rate value in a point of the installation according to the required pressure.

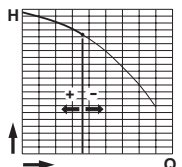

#### Fixed speed mode

with setting of the speed preferential rotation.

In this mode, by changing the working frequency, you may choose any operational curve included within the working range.

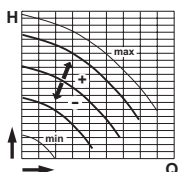

#### Constant temperature mode

with temperature transducer

In this mode the system keeps the temperature constant inside a system by changing the speed of the pump.

Coverage chart n ≈ 2900 rpm

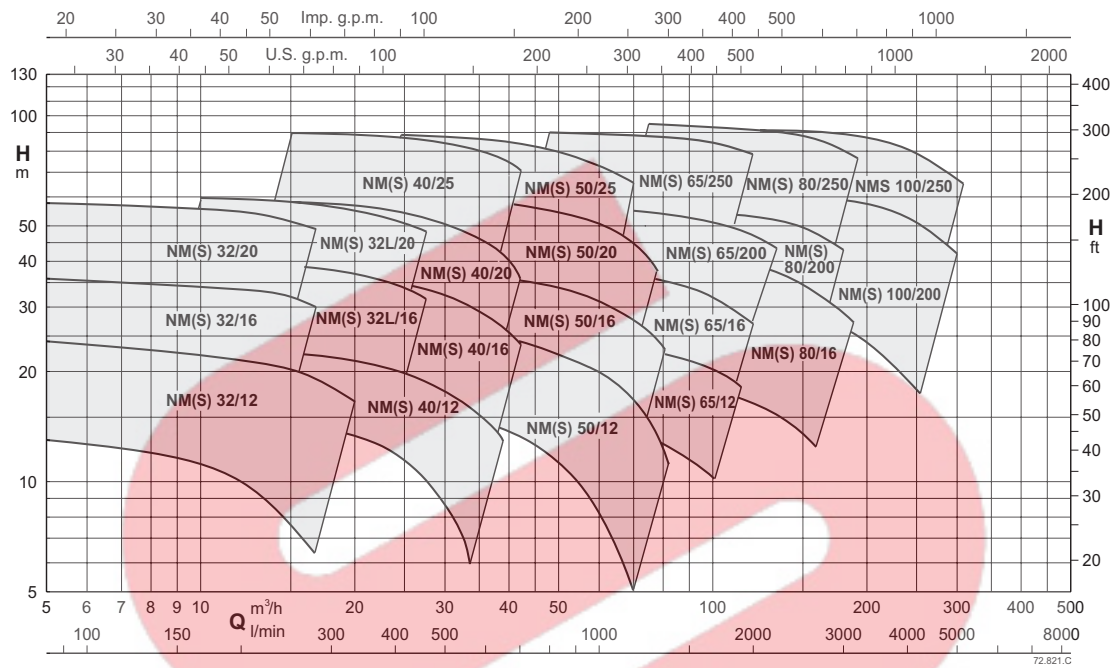

Coverage chart n ≈ 2900 rpm

Three-phase

Model		Electrical Data					Q = Flow													
							H (m) = Total head													
		230V	400V	690V	P2	HP	0	6,6	7,5	8,4	9,6	10,8	12	13,2	15	16,8	18,9	21	24	
							m³/h	110	125	140	160	180	200	220	250	280	315	350	400	
							l/min	300	350	400	450	500	550	600	650	700	750	800	850	900
BNM	NM 32/12F	4	2,3	-	0,55	0,75	13,2	12,5	12,5	12	11,5	11	10	9	7,5	-	-	-	-	
BNM	NM 32/12D	4	2,3	-	0,75	1	18,4	18	17,8	17,5	17,1	16,6	16	15,3	14,1	-	-	-	-	
BNM	NM 32/12A/A	4,6	2,7	-	1,1	1,5	23,5	23	22,8	22,5	22,1	21,6	21,1	20,4	19,3	-	-	-	-	
BNM	NM 32/12S/A	7,5	4,3	-	1,5	2	24	23,6	23,2	22,8	22,4	22	21,6	21,1	20,4	19,5	18,1	16,4	13,1	
BNM	NM 32/16B/A	7,5	4,3	-	1,5	2	30	29,5	29,5	29	28,5	27,5	27	26	25	22,5	-	-	-	
BNM	NM 32/16A/B	9,2	5,3	-	2,2	3	36	35,5	35,2	34,9	34,5	34,1	33,6	33	31,8	30,1	-	-	-	
BNM	NM 32/20D/B	9,2	5,3	-	2,2	3	41	37,5	36,7	35,9	35	34,1	33,1	32	-	-	-	-	-	
BNM	NM 32/20C/A	11,5	6,6	-	3	4	46,4	44,5	44	43,5	42,8	42	41,2	40,2	38,3	35,9	-	-	-	
BNM	NM 32/20A/B	-	9,6	5,5	4	5,5	58,6	57	56,5	56	55,3	54,5	53,6	52,6	50,9	48,9	-	-	-	

Three-phase

Model		Electrical Data					Q = Flow													
							H (m) = Total head													
		230V	400V	690V	P2	HP	0	9,6	10,8	12	13,2	15	16,8	18,9	21	24	27	29	32	
							m³/h	160	180	200	220	250	280	315	350	400	450	483	533	
							l/min	450	500	550	600	650	700	750	800	850	900	950	1000	1050
BNM	NM 32L/16C	9,2	5,3	-	2,2	3	25	25,1	24,9	24,7	24,4	23,8	23	21,8	20,3	17,3	13,4	-	-	
BNM	NM 32L/16B	11,5	6,6	-	3	4	30	30,4	30,3	30,2	30	29,6	29	28,1	26,8	24,2	20,8	17,9	-	
BNM	NM 32L/16A	-	9,6	5,5	4	5,5	38	39,9	39,9	39,8	39,6	39,3	38,8	37,9	36,8	34,7	31,9	29,7	25,6	
BNM	NM 32L/20C	-	9,6	5,5	4	5,5	43	42,1	41,9	41,5	41,1	40,1	38,9	37	34,5	29,8	23,8	-	-	
BNM	NM 32L/20B	-	10,8	6,2	5,5	7,5	52	51,7	51,6	51,4	51,2	50,7	50	48,7	46,9	43,2	37,9	33,4	-	
BNM	NM 32L/20A	-	14,3	8,3	7,5	10	59	59,4	59,5	59,5	59,5	59,3	58,8	57,9	56,4	53,3	48,8	44,9	37,5	

P2: Rated motor power output.

H: Total head in m

Tolerances according to UNI EN ISO 9906:2012

## Coverage chart n ≈ 2900 rpm

### Three-phase

Model		230V 400V 690V P2				Q = Flow														
						m³/h	0													
						l/min	15	16,8	18,9	21	24	27	30	33	37,8	39	42	45	48	
		A	kW	HP	H (m) = Total head															
BNM	NM 40/12F/B	4,6	2,7	-	1,1	1,5	14	14	13,5	12,9	12,1	11	9,6	7,9	6	-	-	-	-	-
BNM	NM 40/12C/B	7,5	4,3	-	1,5	2	17	17,5	17,1	16,6	15,9	14,9	13,6	12,1	10,4	7,4	6,6	-	-	-
BNM	NM 40/12A/C	9,2	5,3	-	2,2	3	21,8	22	21,8	21,5	21	20,1	19,1	17,9	16,4	13,9	13,2	11,4	-	-
BNM	NM 40/16C/C	9,2	5,3	-	2,2	3	23	23	22,7	22,1	21,4	20	18,4	16,6	14,5	11	10	-	-	-
BNM	NM 40/16B/B	11,5	6,6	-	3	4	28	29	28,6	28,1	27,5	26,4	25,1	23,5	21,6	18	16,9	14,1	-	-
BNM	NM 40/16A/C	-	9,6	5,5	4	5,5	36	37	36,7	36,4	35,8	34,9	33,7	32,2	30,4	27	26	23,3	20,3	16,9
BNM	NM 40/20D/B	-	9,6	5,5	4	5,5	42	39	38,1	37	35,6	33,3	30,5	26,9	22,7	14	-	-	-	-
BNM	NM 40/20C/B	-	9,6	5,5	4	5,5	43,5	41,5	40,6	39,4	38,1	36	33,5	-	-	-	-	-	-	-
BNM	NM 40/20B/A	-	10,8	6,2	5,5	7,5	51	50	49,3	48,4	47,4	45,8	43,7	41	37,7	30,5	-	-	-	-
BNM	NM 40/20AR/A	-	10,8	6,2	5,5	7,5	55	55	54,7	53,9	52,9	51,1	49	-	-	-	-	-	-	-
BNM	NM 40/20A/A	-	14,3	8,3	7,5	10	57,5	57,5	57	56,3	55,5	54,3	52,7	50,7	48	42,2	40,4	35,2	-	-
BNM	NM 40/25C/C	-	18,5	10,7	9,2	12,5	62	61	60,9	60,6	59,9	58,4	56,2	53,3	49,6	42	39,7	33,4	-	-
BNM	NM 40/25B/C	-	21,5	12,4	11	15	70	69,5	69,3	68,9	68,4	67,3	65,7	63,4	60,3	53,4	51,2	44,9	-	-
BNM	NM 40/25A/C	-	27,3	15,8	15	20	90	90	89,8	89,5	89,1	88,3	87,1	85,3	82,9	77,5	75,7	70,7	-	-

### Three-phase

Model		230V 400V 690V P2				Q = Flow															
						m³/h	0														
						l/min	24	27	30	33	37,8	42	48	54	60	66	69	72	75	78	81
		A	kW	HP	H (m) = Total head																
BNM	NM 50/12F/C	9,2	5,3	-	2,2	3	16,5	-	-	15,5	15,1	14,2	13,3	11,8	10,1	8,1	5,9	-	-	-	-
BNM	NM 50/12D/B	11,5	6,6	-	3	4	20,5	-	-	20	19,5	18,7	17,8	16,4	14,7	12,8	10,5	9,2	7,9	-	-
BNM	NM 50/12A/C	-	9,6	5,5	4	5,5	24,5	-	-	24	23,8	23,2	22,5	21,1	19,4	17,4	15,1	13,9	12,7	11,4	10
BNM	NM 50/12S/C	-	9,6	5,5	4	5,5	27	-	-	26,5	26,1	25,4	24,7	23,4	21,9	20	17,9	16,7	15,5	14,1	12,7
BNM	NM 50/16B/B	-	10,8	6,2	5,5	7,5	30,5	-	-	31	30,3	29,2	28	26,2	24,1	21,7	18,8	17,2	15,5	13,6	11,6
BNM	NM 50/16A/B	-	14,3	8,3	7,5	10	38	-	-	38,5	38,2	37,4	36,4	34,7	32,5	29,9	27,1	25,5	24	22,3	20,7
BNM	NM 50/20B/C	-	18,5	10,7	9,2	12,5	48	48	47,7	47,3	46,8	45,7	44,6	42,6	40	36,7	32,9	30,6	28,2	25,6	22,8
BNM	NM 50/20A/C	-	21,5	12,4	11	15	54	55	54,9	54,6	54,2	53,3	52,3	50,3	47,9	44,9	41,4	39,4	37,2	35	32,5
BNM	NM 50/20S/C	-	27,3	15,8	15	20	58	60	59,8	59,6	59,2	58,4	57,5	55,8	53,5	50,6	47	45	42,7	40,2	37,5
BNM	NM 50/25C/C	-	21,5	12,4	11	15	55,5	55	54,5	53,9	53,1	51,4	49,5	46	41,4	35,6	28,5	24,5	-	-	-
BNM	NM 50/25B/C	-	27,3	15,8	15	20	68	69	68,6	68	67,3	65,8	64,2	61,1	57,1	52,3	46,4	43,1	-	-	-
BNM	NM 50/25A/D	-	34	19,6	18,5	25	80	80,5	80,3	80	79,5	78,4	77,1	74,6	71,3	67	61,6	58,5	-	-	-
BNM	NM 50/25S	-	41	23,7	22	30	88	88,5	88,5	88	87	86	84	81,5	78,5	75	71	68,5	-	-	-

**P2:** Rated motor power output.

**H:** Total head in m

Tolerances according to UNI EN ISO 9906:2012

### Coverage chart n ≈ 2900 rpm

#### Three-phase

Model		400V 690V P2				Q = Flow															
						m³/h	0														
							37,8	42	48	54	60	66	75	84	96	108	120	132	141		
						l/min	630	700	800	900	1000	1100	1250	1400	1600	1800	2000	2200	2350		
		A		kW		HP		H (m) = Total head													
BNM	NM 65/12E/C	9,6	5,5	4	5,5	16,5	16,5	16,4	16,2	15,9	15,5	15,1	14,3	13,2	11,4	9,2	-	-	-		
BNM	NM 65/12C/B	10,8	6,2	5,5	7,5	20,5	21,1	21	20,8	20,6	20,3	19,9	19,1	18,2	16,5	14,4	11,8	-	-		
BNM	NM 65/12A/B	14,3	8,3	7,5	10	25,5	25,9	25,8	25,6	25,4	25,1	24,8	24,1	23,3	21,9	20	17,6	-	-		
BNM	NM 65/16D/B	14,3	8,3	7,5	10	24	-	-	24,3	24,1	23,9	23,6	23,1	22,3	20,8	18,8	16,3	-	-		
BNM	NM 65/16C/C	18,5	10,7	9,2	12,5	26,5	-	-	28,1	28	27,8	27,6	27,1	26,3	24,9	23,1	20,7	17,7	-		
BNM	NM 65/16B/C	21,5	12,4	11	15	31,8	-	-	32,6	32,5	32,3	32	31,5	30,8	29,5	27,9	25,7	23	-		
BNM	NM 65/16AR	27,3	15,8	15	20	35,5	-	-	36,4	36,3	36,2	35,9	35,5	34,8	33,7	32,1	30	27,5	-		
BNM	NM 65/16A/C	27,3	15,8	15	20	39	-	-	40,5	40,4	40,2	40	39,5	38,8	37,6	36,1	34,1	31,7	-		
BNM	NM 65/20C/C	27,3	15,8	15	20	41	-	-	44	43,8	43,5	43,1	42,3	41,2	39,4	37,1	34,4	31,4	28,8		
-	NM 65/20B/D	34	19,6	18,5	25	47	-	-	50,5	50,4	50,2	49,9	49,2	48,3	46,8	44,8	42,5	39,8	37,5		
-	NM 65/20A/A	41	23,7	22	30	54	-	-	57	57	56,9	56,6	56,1	55,4	54	52,3	50,1	47,6	45,4		
BNM	NM 65/25C/A	41	23,7	22	30	56	-	-	61	60,8	60,4	59,8	58,7	57,2	54,6	51,3	47,5	43	-		
BNMS	NMS 65/250B/B	-	-	30	40	68	-	-	73,5	73,7	73,7	73,5	72,8	71,6	69,4	66,6	63,1	59	-		
BNMS	NMS 65/250A/B	-	-	37	50	80	-	-	86,5	86,7	86,8	86,7	86,1	85,2	83,5	81,1	78,1	74,5	-		

#### Three-phase

Model		400V 690V P2				Q = Flow															
						m³/h	0														
							75	84	96	108	120	132	150	168	180	192	210	240	270	300	
						l/min	1250	1400	1600	1800	2000	2200	2500	2800	3000	3200	3500	4000	4500	5000	
		A		kW		HP		H (m) = Total head													
BNM	NM 80/16E/B	14,3	8,3	7,5	10	24	21,5	20,9	19,9	18,7	17,4	15,9	13,4	10,6	-	-	-	-	-	-	
BNM	NM 80/16D/C	18,5	10,7	9,2	12,5	26	25,2	24,5	23,5	22,4	21,1	19,6	17,2	14,4	-	-	-	-	-	-	
BNM	NM 80/16C/C	22,4	12,9	11	15	28	28,7	28,2	27,4	26,4	25,2	23,8	21,3	18,5	16,4	-	-	-	-	-	
BNM	NM 80/16B/C	27,3	15,8	15	20	35	34,8	34,4	33,8	33	32,1	30,9	28,9	26,4	24,5	22,4	-	-	-	-	
BNM	NM 80/16A/D	34	19,6	18,5	25	40	39,9	39,5	39	38,3	37,4	36,4	34,5	32,2	30,3	28,1	-	-	-	-	
-	NM 80/20B/A	41	23,7	22	30	42	44,4	43,9	43,2	42,4	41,5	40,5	38,6	36,4	34,6	32,5	-	-	-	-	
BNMS	NMS 80/200A/B	-	-	30	40	54,4	56,6	56,3	55,8	55,2	54,4	53,5	51,7	49,4	47,7	45,6	-	-	-	-	
-	NM 80/25E	41	23,7	22	30	52	51	50	48,4	46,6	44,5	42,1	37,9	32,9	29,1	-	-	-	-	-	
BNMS	NMS 80/250D/A	-	-	30	40	65	65	63,9	62,4	60,8	58,9	56,9	53,2	48,7	45,2	41,2	-	-	-	-	
BNMS	NMS 80/250C/A	-	-	37	50	74	73,5	72,9	71,9	70,6	68,9	66,9	63,3	58,8	55,4	51,6	-	-	-	-	
BNMS	NMS 80/250B/A	-	-	45	60	84	84	83,5	82,6	81,4	79,9	78,1	74,7	70,4	66,9	63,1	-	-	-	-	
BNMS	NMS 80/250A/A	-	-	55	75	95	95	94,3	93,4	92,5	91,5	90,2	87,5	83,8	80,5	76,5	-	-	-	-	
-	NM 100/20E/A	34	19,6	18,5	25	30	-	-	-	30	29,5	29	28,1	26,9	26	25	23,1	19	-	-	
-	NM 100/20D	41	23,7	22	30	36	-	-	-	36	35,5	35	34,1	32,9	32	30,9	28,9	24,7	18,9	-	
BNMS	NMS 100/200C/A	-	-	30	40	45,5	-	-	-	45	44,6	44,2	43,4	42,4	41,6	40,5	38,7	34,6	29,1	21,9	
BNMS	NMS 100/200B/A	-	-	37	50	54,2	-	-	-	54	53,6	53,2	52,4	51,4	50,6	49,6	47,8	43,9	38,7	31,9	
BNMS	NMS 100/200A/A	-	-	45	60	62	-	-	-	61,5	61,1	60,8	60,1	59,3	58,6	57,8	56,4	53	48,3	41,9	
BNMS	NMS 100/250B/A	-	-	55	75	74	-	-	-	73,5	73	72,4	71,2	69,8	68,7	67,4	65,2	60,8	55,3	48,6	
BNMS	NMS 100/250A/A	-	-	75	100	92	-	-	-	91	90,6	90,2	89,5	88,6	87,8	86,9	85,1	81	75,1	66,9	

**P2:** Rated motor power output.

**H:** Total head in m

Tolerances according to UNI EN ISO 9906:2012

Coverage chart n ≈ 2900 rpm

Rated current

Motor P2	IE3			IE4		
	400V	690V	la/In	400V	690V	la/In
0.55	2.3	-	4.8	2.3	-	4.8
0.75	2.3	-	6.1	2.3	-	6.1
1.1	2.7	-	5.5	2.7	-	5.5
1.5	4.3	-	6.1	4.3	-	6.1
2.2	5.3	-	8.4	5.3	-	8.4
3	6.6	-	8.2	6.6	-	8.2
4	9.6	5.5	8.9	7.3	4.2	7.5
5.5	10.8	6.2	9.1	10.8	6.2	9.1
7.5	14.3	8.3	9.1	13.4	7.8	7.5
9.2	18.5	10.7	8.2	18.5	10.7	8.2
11	21.5	12.4	8.5	21.5	12.4	8.5
15	27.3	15.8	9.5	27.3	15.8	9.5
18.5	34	19.6	9.5	34	19.6	9.5
22	41	23.7	9.5	38	22	9.5
30	53	30.5	8.6	51.5	29.9	9
37	65	37.5	7.1	63.3	36.7	9
45	78	45	6.9	76.8	44.5	9
55	95	55	6.7	93.6	54.3	9
75	128	74	6.8	127.2	73.7	8.5

A\*: Calpeda motor Standard  
 la/In D.O.L. starting current / Nominal current

Coverage chart n ≈ 2900 rpm

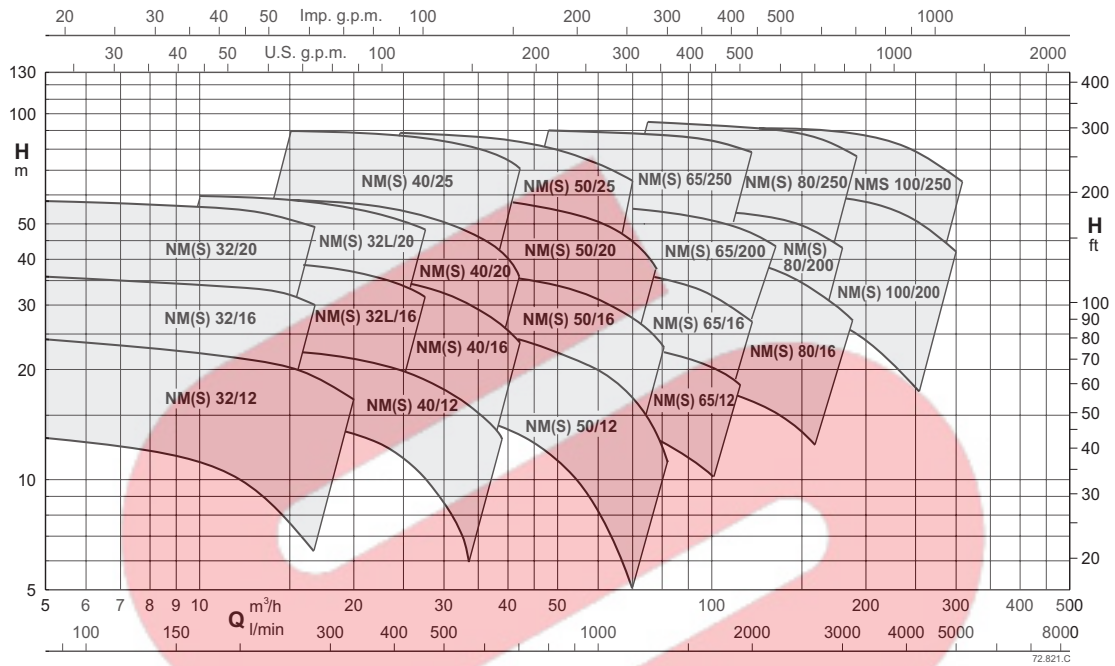

Coverage chart n ≈ 2900 rpm

Three-phase

Model		P2		Q = Flow															
				m³/h	0	6,6	7,5	8,4	9,6	10,8	12	13,2	15	16,8	18,9	21	24	27	
				l/min	110	125	140	160	180	200	220	250	280	315	350	400	450		
		kW		HP		H (m) = Total head													
BNMS	NMS 32/125D	0,75	1		18,4	18	17,8	17,5	17,1	-	-	-	-	-	-	-	-	-	
BNMS	NMS 32/125D-S	1,1	1,5		18,4	18	17,8	17,5	17,1	16,6	16	15,3	14,1	12,7	10,8	8,6	-	-	
BNMS	NMS 32/125A	1,1	1,5		24,3	23	22,8	22,5	22,1	21,6	21,1	20,4	-	-	-	-	-	-	
BNMS	NMS 32/125A-S	1,5	2		24,3	23	22,8	22,5	22,1	21,6	21,1	20,4	19,3	18	16,2	13,9	10	-	
BNMS	NMS 32/125S	1,5	2		25	23,6	23,2	22,8	22,4	22	21,6	21,1	20,4	19,5	18,1	16,4	13,1	-	
BNMS	NMS 32/160B	1,5	2		29,3	29,5	29,3	29	28,4	27,8	27	26,1	24,5	-	-	-	-	-	
BNMS	NMS 32/160B-S	2,2	3		31,8	29,5	29,3	29	28,4	27,8	27	26,1	24,5	22,7	20,2	17,3	12,5	-	
BNMS	NMS 32/160A	2,2	3		36	35,5	35,2	34,9	34,5	34,1	33,6	33	31,8	30,1	-	-	-	-	
BNMS	NMS 32/160A-S	3	4		36	35,5	35,2	34,9	34,5	34,1	33,6	33	31,8	30,1	28	25,3	20,8	15	
BNMS	NMS 32/200D	2,2	3		41	37,5	36,7	35,9	35	34,1	-	-	-	-	-	-	-	-	
BNMS	NMS 32/200D-S	3	4		41	37,5	36,7	35,9	35	34,1	33,1	32	29,9	26,9	22,1	-	-	-	
BNMS	NMS 32/200C	3	4		46,1	44,5	44	43,5	42,8	42	41,2	40,2	38,3	35,9	32,1	-	-	-	
BNMS	NMS 32/200A	4	5,5		58,7	57	56,5	56	55,3	54,5	53,6	52,6	50,9	-	-	-	-	-	
BNMS	NMS 32/200A-S	5,5	7,5		58,7	57	56,5	56	55,3	54,5	53,6	52,6	50,9	48,9	46,1	-	-	-	

Three-phase

Model		P2		Q = Flow														
				m³/h	0	9,6	10,8	12	13,2	15	16,8	18,9	21	24	27	29	32	
				l/min	160	180	200	220	250	280	315	350	400	450	483	533		
		kW		HP		H (m) = Total head												
BNMS	NMS 32L/160C	2,2	3		25,7	25,1	24,9	24,7	24,4	23,8	23	21,8	20,3	17,3	13,4	-	-	
BNMS	NMS 32L/160B	3	4		30,4	30,4	30,3	30,2	30	29,6	29	28,1	26,8	24,2	20,8	17,9	-	
BNMS	NMS 32L/160A	4	5,5		38,5	39,9	39,9	39,8	39,6	39,3	38,8	37,9	36,8	34,7	31,9	29,7	25,6	
BNMS	NMS 32L/200C	4	5,5		41,3	42,1	41,9	41,5	41,1	40,1	38,9	37	34,5	29,8	23,8	-	-	
BNMS	NMS 32L/200B	5,5	7,5		53	51,7	51,6	51,4	51,2	50,7	50	48,7	46,9	43,2	37,9	33,4	-	
BNMS	NMS 32L/200A	7,5	10		57,7	59,4	59,5	59,5	59,5	59,3	58,8	57,9	56,4	53,3	48,8	44,9	37,5	

P2: Rated motor power output.

H: Total head in m

Tolerances according to UNI EN ISO 9906:2012

## Coverage chart n ≈ 2900 rpm

### Three-phase

		P2		Q = Flow																
				m³/h	0	15	16,8	18,9	21	24	27	30	33	37,8	39	42	45	48		
Model		P2		l/min	250	280	315	350	400	450	500	550	630	650	700	750	800			
		kW		HP		H (m) = Total head														
BNMS	NMS 40/125F	1,1	1,5		14	14	13,5	12,9	12,1	11	9,6	7,9	6	-	-	-	-	-		
BNMS	NMS 40/125C	1,5	2		17	17,5	17,1	16,6	15,9	14,9	13,6	12,1	10,4	7,4	6,6	-	-	-		
BNMS	NMS 40/125A	2,2	3		21,8	22	21,8	21,5	21	20,1	19,1	17,9	16,4	13,9	13,2	11,4	-	-		
BNMS	NMS 40/160C	2,2	3		23	23	22,7	22,1	21,4	20	18,4	16,6	14,5	11	10	-	-	-		
BNMS	NMS 40/160B	3	4		29,9	29	28,6	28,1	27,5	26,4	25,1	23,5	21,6	18	16,9	14,1	-	-		
BNMS	NMS 40/160A	4	5,5		36	37	36,7	36,4	35,8	34,9	33,7	32,2	30,4	27	-	-	-	-		
BNMS	NMS 40/160A-S	5,5	7,5		36	37	36,7	36,4	35,8	34,9	33,7	32,2	30,4	27	26	23,3	20,3	16,9		
BNMS	NMS 40/200D	4	5,5		41	39	38,1	37	35,6	33,3	30,5	-	-	-	-	-	-	-		
BNMS	NMS 40/200D-S	5,5	7,5		41	39	38,1	37	35,6	33,3	30,5	26,9	22,7	14	-	-	-	-		
BNMS	NMS 40/200C	4	5,5		43	41,5	40,6	39,4	38,1	-	-	-	-	-	-	-	-	-		
BNMS	NMS 40/200C-S	5,5	7,5		43	41,5	40,6	39,4	38,1	36	33,5	-	-	-	-	-	-	-		
BNMS	NMS 40/200B	5,5	7,5		50,5	50	49,3	48,4	47,4	45,8	43,7	41	37,7	-	-	-	-	-		
BNMS	NMS 40/200B-S	7,5	10		50,5	50	49,3	48,4	47,4	45,8	43,7	41	37,7	30,5	-	-	-	-		
BNMS	NMS 40/200AR	5,5	7,5		55	55	54,7	53,9	52,9	51,1	-	-	-	-	-	-	-	-		
BNMS	NMS 40/200AR-S	7,5	10		55	55	54,7	53,9	52,9	51,1	49	-	-	-	-	-	-	-		
BNMS	NMS 40/200A	7,5	10		57,5	57,5	57	56,3	55,5	54,3	52,7	50,7	48	42,2	40,4	35,2	-	-		
BNMS	NMS 40/250C	11	15		62	61	60,9	60,6	59,9	58,4	56,2	53,3	49,6	42	39,7	33,4	-	-		
BNMS	NMS 40/250B	11	15		70	69,5	69,3	68,9	68,4	67,3	65,7	63,4	60,3	53,4	51,2	44,9	-	-		
BNMS	NMS 40/250A	15	20		90	90	89,8	89,5	89,1	88,3	87,1	85,3	82,9	77,5	75,7	70,7	-	-		

### Three-phase

		P2		Q = Flow																
				m³/h	0	24	27	30	33	37,8	42	48	54	60	66	69	72	75	78	81
Model		P2		l/min	400	450	500	550	630	700	800	900	1000	1100	1150	1200	1250	1300	1350	
		kW		HP		H (m) = Total head														
BNMS	NMS 50/125F	2,2	3		16,5	-	-	15,5	15,1	14,2	13,3	11,8	10,1	8,1	5,9	-	-	-	-	-
BNMS	NMS 50/125D	3	4		20,5	-	-	20	19,5	18,7	17,8	16,4	14,7	12,8	10,5	9,2	7,9	-	-	-
BNMS	NMS 50/125A	4	5,5		24,1	-	-	24	23,8	23,2	22,5	21,1	19,4	17,4	15,1	13,9	12,7	11,4	10	-
BNMS	NMS 50/125S	4	5,5		27,6	-	-	26,5	26,1	25,4	24,7	23,4	21,9	-	-	-	-	-	-	-
BNMS	NMS 50/125S-S	5,5	7,5		27,6	-	-	26,5	26,1	25,4	24,7	23,4	21,9	20	17,9	16,7	15,5	14,1	12,7	11,1
BNMS	NMS 50/160B	5,5	7,5		30,5	-	-	31	30,3	29,2	28	26,2	24,1	21,7	18,8	17,2	15,5	13,6	11,6	9,5
BNMS	NMS 50/160A	7,5	10		38	-	-	38,5	38,2	37,4	36,4	34,7	32,5	29,9	27,1	25,5	24	22,3	20,7	19
BNMS	NMS 50/200B	11	15		48,4	48	47,7	47,3	46,8	45,7	44,6	42,6	40	36,7	32,9	30,6	28,2	25,6	22,8	-
BNMS	NMS 50/200A	11	15		54	55	54,9	54,6	54,2	53,3	52,3	50,3	47,9	44,9	41,4	39,4	37,2	35	32,5	-
BNMS	NMS 50/200S	15	20		59	60	59,8	59,6	59,2	58,4	57,5	55,8	53,5	50,6	47	45	42,7	40,2	37,5	-
BNMS	NMS 50/250C	11	15		55,1	55	54,5	53,9	53,1	51,4	49,5	46	41,4	35,6	28,5	24,5	-	-	-	-
BNMS	NMS 50/250B	15	20		69	69	68,6	68	67,3	65,8	64,2	61,1	57,1	52,3	46,4	43,1	-	-	-	-
BNMS	NMS 50/250A	18,5	25		80	80,5	80,3	80	79,5	78,4	77,1	74,6	71,3	67	61,6	58,5	-	-	-	-

**P2:** Rated motor power output.

**H:** Total head in m

Tolerances according to UNI EN ISO 9906:2012

## Coverage chart n ≈ 2900 rpm

### Three-phase

Model		P2		Q = Flow															
				m³/h	0	37,8	42	48	54	60	66	75	84	96	108	120	132	141	
				l/min	630	700	800	900	1000	1100	1250	1400	1600	1800	2000	2200	2350		
		kW		HP		H (m) = Total head													
BNMS	NMS 65/125E	4	5,5		16,2	16,5	16,4	16,2	15,9	15,5	15,1	14,3	13,2	11,4	9,2	-	-	-	
BNMS	NMS 65/125C	5,5	7,5		20,8	21,1	21	20,8	20,6	20,3	19,9	19,1	18,2	16,5	14,4	11,8	-	-	
BNMS	NMS 65/125A	7,5	10		26	25,9	25,8	25,6	25,4	25,1	24,8	24,1	23,3	21,9	20	17,6	-	-	
BNMS	NMS 65/160D	7,5	10		24	-	-	24,3	24,1	23,9	23,6	23,1	22,3	20,8	18,8	16,3	-	-	
BNMS	NMS 65/160C	11	15		27,8	-	-	28,1	28	27,8	27,6	27,1	26,3	24,9	23,1	20,7	17,7	-	
BNMS	NMS 65/160B	11	15		31,8	-	-	32,6	32,5	32,3	32	31,5	30,8	29,5	27,9	25,7	23	-	
BNMS	NMS 65/160AR	15	20		35,8	-	-	36,4	36,3	36,2	35,9	35,5	34,8	33,7	32,1	30	27,5	-	
BNMS	NMS 65/160A	15	20		38,8	-	-	40,5	40,4	40,2	40	39,5	38,8	37,6	36,1	34,1	31,7	-	
BNMS	NMS 65/200C	15	20		41	-	-	44	43,8	43,5	43,1	42,3	41,2	39,4	37,1	34,4	31,4	28,8	
BNMS	NMS 65/200B	18,5	25		47	-	-	50,5	50,4	50,2	49,9	49,2	48,3	46,8	44,8	42,5	39,8	37,5	
BNMS	NMS 65/200A	22	30		54	-	-	57	57	56,9	56,6	56,1	55,4	54	52,3	50,1	47,6	45,4	
BNMS	NMS 65/250C	22	30		56	-	-	61	60,8	60,4	59,8	58,7	57,2	54,6	51,3	47,5	43	-	
BNMS	NMS 65/250B/B	30	40		68	-	-	73,5	73,7	73,7	73,5	72,8	71,6	69,4	66,6	63,1	59	-	
BNMS	NMS 65/250A/B	37	50		80	-	-	86,5	86,7	86,8	86,7	86,1	85,2	83,5	81,1	78,1	74,5	-	

### Three-phase

Model		P2		Q = Flow															
				m³/h	0	75	84	96	108	120	132	150	168	180	192	210	240	270	300
				l/min	1250	1400	1600	1800	2000	2200	2500	2800	3000	3200	3500	4000	4500	5000	
		kW		HP		H (m) = Total head													
BNMS	NMS 80/160E	7,5	10		23	21,5	20,9	19,9	18,7	17,4	15,9	13,4	10,6	-	-	-	-	-	
BNMS	NMS 80/160D	11	15		26	25,2	24,5	23,5	22,4	21,1	19,6	17,2	14,4	-	-	-	-	-	
BNMS	NMS 80/160C	11	15		29	28,7	28,2	27,4	26,4	25,2	23,8	21,3	18,5	16,4	-	-	-	-	
BNMS	NMS 80/160B	15	20		35	34,8	34,4	33,8	33	32,1	30,9	28,9	26,4	24,5	22,4	-	-	-	
BNMS	NMS 80/160A	18,5	25		40	39,9	39,5	39	38,3	37,4	36,4	34,5	32,2	30,3	28,1	-	-	-	
BNMS	NMS 80/200B/B	22	30		42	44,4	43,9	43,2	42,4	41,5	40,5	38,6	36,4	34,6	32,5	-	-	-	
BNMS	NMS 80/200A/B	30	40		54,4	56,6	56,3	55,8	55,2	54,4	53,5	51,7	49,4	47,7	45,6	-	-	-	
BNMS	NMS 80/250E	22	30		52	51	50	48,4	46,6	44,5	42,1	37,9	32,9	29,1	-	-	-	-	
BNMS	NMS 80/250D/A	30	40		65	65	63,9	62,4	60,8	58,9	56,9	53,2	48,7	45,2	41,2	-	-	-	
BNMS	NMS 80/250C/A	37	50		74	73,5	72,9	71,9	70,6	68,9	66,9	63,3	58,8	55,4	51,6	-	-	-	
BNMS	NMS 80/250B/A	45	60		84	84	83,5	82,6	81,4	79,9	78,1	74,7	70,4	66,9	63,1	-	-	-	
BNMS	NMS 80/250A/A	55	75		95	95	94,3	93,4	92,5	91,5	90,2	87,5	83,8	80,5	76,5	-	-	-	
BNMS	NMS 100/200E	18,5	25		30	-	-	-	30	29,5	29	28,1	26,9	26	25	23,1	19	-	
BNMS	NMS 100/200D/A	22	30		36	-	-	-	36	35,5	35	34,1	32,9	32	30,9	28,9	24,7	18,9	
BNMS	NMS 100/200C/A	30	40		45,5	-	-	-	45	44,6	44,2	43,4	42,4	41,6	40,5	38,7	34,6	29,1	
BNMS	NMS 100/200B/A	37	50		54,2	-	-	-	54	53,6	53,2	52,4	51,4	50,6	49,6	47,8	43,9	38,7	
BNMS	NMS 100/200A/A	45	60		62	-	-	-	61,5	61,1	60,8	60,1	59,3	58,6	57,8	56,4	53	48,3	
BNMS	NMS 100/250B/A	55	75		74	-	-	-	73,5	73	72,4	71,2	69,8	68,7	67,4	65,2	60,8	55,3	
BNMS	NMS 100/250A/A	75	100		92	-	-	-	91	90,6	90,2	89,5	88,6	87,8	86,9	85,1	81	75,1	

**P2:** Rated motor power output.

**H:** Total head in m

Tolerances according to UNI EN ISO 9906:2012

## Coverage chart n ≈ 2900 rpm

### Rated current

Motor	IE3			IE4		
	400V	690V	la/In	400V	690V	la/In
P2	A	A		A	A	
kW	A	A	la/In	A	A	la/In
0.55	2.3	-	4.8	2.3	-	4.8
0.75	2.3	-	6.1	2.3	-	6.1
1.1	2.7	-	5.5	2.7	-	5.5
1.5	4.3	-	6.1	4.3	-	6.1
2.2	5.3	-	8.4	5.3	-	8.4
3	6.6	-	8.2	6.6	-	8.2
4	9.6	5.5	8.9	7.3	4.2	7.5
5.5	10.8	6.2	9.1	10.8	6.2	9.1
7.5	14.3	8.3	9.1	13.4	7.8	7.5
9.2	18.5	10.7	8.2	18.5	10.7	8.2
11	21.5	12.4	8.5	21.5	12.4	8.5
15	27.3	15.8	9.5	27.3	15.8	9.5
18.5	34	19.6	9.5	34	19.6	9.5
22	41	23.7	9.5	38	22	9.5
30	53	30.5	8.6	51.5	29.9	9
37	65	37.5	7.1	63.3	36.7	9
45	78	45	6.9	76.8	44.5	9
55	95	55	6.7	93.6	54.3	9
75	128	74	6.8	127.2	73.7	8.5

A\*: Calpeda motor Standard  
**la/In** D.O.L. starting current / Nominal current

## Coverage chart n ≈ 1450 rpm

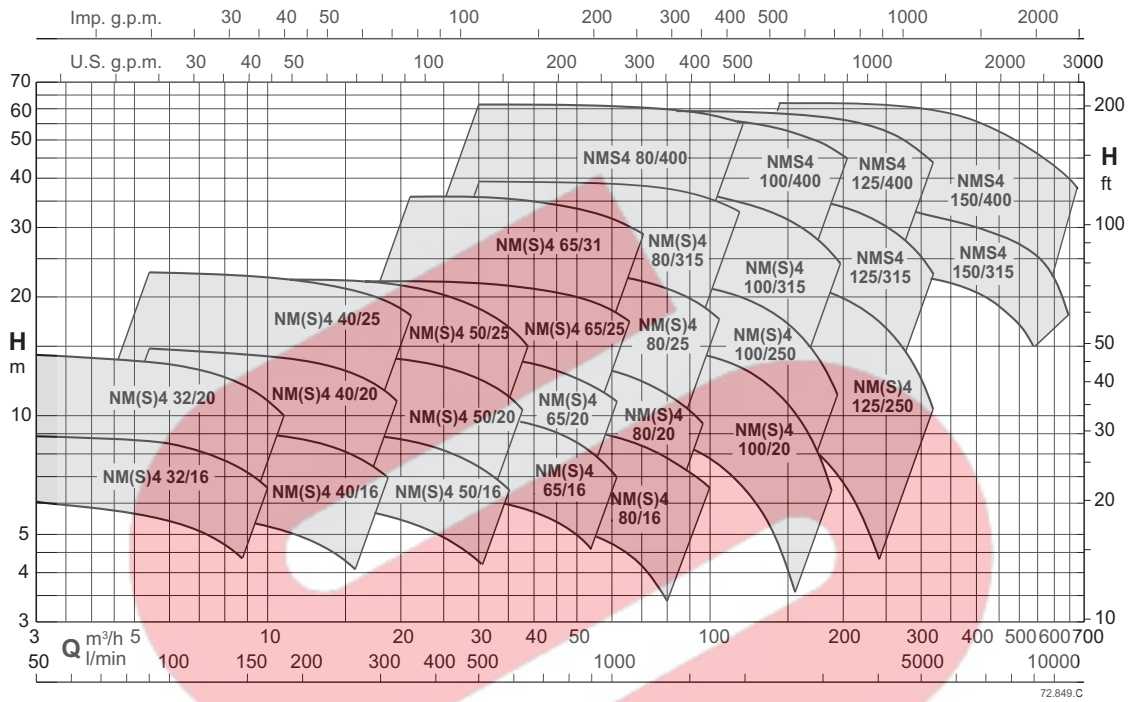

## Performance n ≈ 1450 rpm

### Three-phase

Model		230V		400V		P2		Q = Flow															
		A	kW	HP	m³/h	l/min	0	2,4	3	3,6	4,2	4,8	5,4	6	7,5	8,4	9,6	10,8	12	13,2			
								H (m) = Total head															
BNM4	NM4 32/16B/A	1,65	0,95	0,37	0,5		7,6	7,6	7,5	7,4	-	7,2	7,1	6,9	6,3	5,9	5,2	4,2	-	-			
BNM4	NM4 32/16A/A	1,65	0,95	0,37	0,5		9	9	8,9	8,9	-	8,7	8,6	8,5	7,9	7,5	6,8	6	5,1	-			
BNM4	NM4 32/20B/A	2,6	1,5	0,55	0,75		12,5	12,5	12,4	12,4	12,2	12	11,8	11,5	10,6	9,9	8,9	7,7	6,2	4,7			
BNM4	NM4 32/20A/B	3,3	1,9	0,75	1		14,2	14,3	14,2	14,2	14,1	13,9	13,7	13,5	12,8	12,2	11,3	10,3	9	7,4			

### Three-phase

Model		230V		400V		P2		Q = Flow															
		A	kW	HP	m³/h	l/min	0	5,4	6	7,5	8,4	9,6	10,8	12	13,2	15	16,8	18,9	21	24	27	30	
								H (m) = Total head															
BNM4	NM4 40/16C/B	1,65	0,95	0,37	0,5		5,9	6,1	6	5,9	5,8	5,6	5,4	5,2	5	4,5	3,9	3,1	2,3	-	-	-	
BNM4	NM4 40/16B/B	2,6	1,5	0,55	0,75		7,3	7,6	7,6	7,6	7,6	7,3	7,1	6,9	6,6	6,3	5,7	5	4	2,7	-	-	
BNM4	NM4 40/16A/C	3,3	1,9	0,75	1		9,3	9,6	9,6	9,6	9,4	9,3	9,1	9	8,8	8,4	7,9	7,2	6,4	5,1	3,5	-	
BNM4	NM4 40/20B/B	5	2,9	1,1	1,5		13	13	12,9	12,7	12,6	12,4	12,2	12	11,5	10,8	10	8,6	7	-	-	-	
BNM4	NM4 40/20A/B	5	2,9	1,1	1,5		14,8	14,8	14,7	14,5	14,4	14,2	14	13,8	13,6	13	12,2	11,3	10	-	-	-	
BNM4	NM4 40/25C/C	6	3,5	1,5	2		17,4	17,4	17,3	17,2	17	16,8	16,6	16,3	16	15,1	13,8	12,1	10,4	7,2	2,8	-	
BNM4	NM4 40/25B/C	8,6	5	2,2	3		21,3	21,4	21,5	21,3	21,2	21	20,9	20,8	20,5	20	19,5	18,3	16,4	13,3	10	5	
BNM4	NM4 40/25A/B	11,1	6,4	3	4		22,8	22,9	22,8	22,9	22,8	22,5	22,5	22,2	22	21,8	21,4	20,4	18,9	16	12,6	8	

P2: Rated motor power output.

H: Total head in m

Tolerances according to UNI EN ISO 9906:2012

## Performance n ≈ 1450 rpm

### Three-phase

Model		230V 400V 690V P2				Q = Flow															
						m³/h	0														
							10,8	12	13,2	15	16,8	18,9	21	24	27	30	33	37,8	42	48	
						l/min	180	200	220	250	280	315	350	400	450	500	550	630	700	800	
		A		kW HP		H (m) = Total head															
BNM4	NM4 50/16B/C	5	2,9	-	1,1	1,5	8	8,2	8,2	8,2	8,1	8	7,8	7,6	7,2	6,7	6,2	5,5	4,4	3,3	-
BNM4	NM4 50/16A/C	5	2,9	-	1,1	1,5	9,5	9,6	9,6	9,6	9,5	9,5	9,3	9,1	8,8	8,3	7,8	7,2	6,1	4,9	3,1
BNM4	NM4 50/20C/C	5	2,9	-	1,1	1,5	11,3	11,8	11,8	11,7	11,7	11,5	11,3	10,9	10,4	9,8	9	8,1	6,3	4,7	-
BNM4	NM4 50/20B/C	6	3,5	-	1,5	2	13	13,4	13,4	13,4	13,3	13,1	12,9	12,6	12,1	11,5	10,8	9,9	8,2	6,4	3,7
BNM4	NM4 50/20A/C	8,6	5	-	2,2	3	14,5	14,9	14,9	14,9	14,9	14,8	14,6	14,4	14	13,4	12,8	12	10,4	8,6	6
BNM4	NM4 50/25D/B	8,6	5	-	2,2	3	14,4	14,5	14,4	14,3	14	13,7	13,4	13	12,2	11,2	9,7	8,1	5,4	2,3	-
BNM4	NM4 50/25C/C	8,6	5	-	2,2	3	17,2	17,8	17,8	17,7	17,5	17,2	16,8	16,4	15,7	14,9	13,8	12,4	9,7	6,8	-
BNM4	NM4 50/25B/B	11,1	6,4	-	3	4	20,4	20,7	20,7	20,7	20,6	20,4	20	19,5	18,9	18,2	17,1	15,9	13,2	10,6	5,8
BNM4	NM4 50/25A/B	-	8,3	4,8	4	5,5	22,3	22,7	22,7	22,6	22,5	22,4	22,1	21,6	21	20,2	19,4	18,3	16,4	13,6	9

### Three-phase

Model		230V 400V 690V P2				Q = Flow															
						m³/h	0														
							21	24	27	30	33	37,8	42	48	54	60	66	75	84	96	
						l/min	350	400	450	500	550	630	700	800	900	1000	1100	1250	1400	1600	
		A		kW HP		H (m) = Total head															
BNM4	NM4 65/16C/C	5	2,9	-	1,1	1,5	6	6,1	6,1	6	6	5,9	5,8	5,6	5,3	4,8	4,2	-	-	-	-
BNM4	NM4 65/16B/C	5	2,9	-	1,1	1,5	7,1	7,2	7,1	7,1	7	7	6,8	6,6	6,3	5,8	5,2	4,5	-	-	-
BNM4	NM4 65/16A/C	6	3,5	-	1,5	2	8,6	8,8	8,8	8,7	8,7	8,6	8,5	8,3	8	7,6	7,1	6,4	5,2	-	-
BNM4	NM4 65/16S/A	8,6	5	-	2,2	3	9,9	10,2	10,2	10,1	10,1	10	9,9	9,7	9,4	9,1	8,6	8	7	5,7	-
BNM4	NM4 65/20B/C	8,6	5	-	2,2	3	11,1	11,7	11,7	11,6	11,6	11,5	11,3	11	10,6	10,1	9,5	8,7	7,4	5,8	3,3
BNM4	NM4 65/20A/B	11,1	6,4	-	3	4	13,5	14,2	14,2	14,2	14,1	14,1	13,9	13,7	13,4	13	12,5	11,8	10,7	9,3	7
BNM4	NM4 65/25B/B	-	8,3	4,8	4	5,5	16,5	17,9	18	18	18	18	17,8	17,5	17	16,3	15,4	14,4	12,5	10,4	7
BNM4	NM4 65/25A/C	-	12,5	7,2	5,5	7,5	21	22,2	22,3	22,4	22,4	22,4	22,2	22	21,6	21	20,2	19,3	17,6	15,7	12,6
BNM4	NM4 65/31C/B	-	12,5	7,2	5,5	7,5	26	25,8	25,7	25,5	25,3	25	24,4	23,8	22,8	21,5	20	18,2	15	11	-
BNM4	NM4 65/31B/B	-	16	9,2	7,5	10	31	31	31	30,9	30,8	30,6	30,2	29,7	28,8	27,8	26,5	25	22,2	18,6	-
BNM4	NM4 65/31A/B	-	20,5	11,8	9,2	12,5	36	35,9	35,9	35,8	35,7	35,5	35,1	34,6	33,8	32,8	31,6	30,2	27,8	25	-

### Three-phase

Model		230V 400V 690V P2				Q = Flow																	
						m³/h	0																
							30	33	37,8	42	48	54	60	66	75	84	96	108	120	132	150	168	180
						l/min	500	550	630	700	800	900	1000	1100	1250	1400	1600	1800	2000	2200	2500	2800	3000
		A		kW HP		H (m) = Total head																	
-	NM4 80/16C/C	5	2,9	-	1,1	1,5	6,6	6,1	6,1	5,9	5,8	5,5	5,2	4,9	4,6	4	3,3	-	-	-	-	-	-
-	NM4 80/16B/C	6	3,5	-	1,5	2	8,1	7,8	7,7	7,6	7,5	7,3	7	6,8	6,4	5,9	5,2	4,1	-	-	-	-	-
-	NM4 80/16A/C	8,6	5	-	2,2	3	10,1	10	10	9,9	9,8	9,7	9,5	9,3	9	8,5	8	7	5,9	-	-	-	-
BNM4	NM4 80/20C/C	8,6	5	-	2,2	3	8,6	9	9	8,9	8,8	8,7	8,5	8,2	7,9	7,4	6,8	5,7	4,3	2,7	-	-	-
BNM4	NM4 80/20B/B	11,1	6,4	-	3	4	11,3	11,7	11,7	11,7	11,6	11,5	11,3	11,1	10,8	10,3	9,7	8,7	7,4	5,9	4,1	-	-
BNM4	NM4 80/20A/B	-	8,3	4,8	4	5,5	13,7	14,2	14,2	14,1	14	13,9	13,7	13,5	13,2	12,7	12,1	11,1	9,9	8,5	6,9	-	-
BNM4	NM4 80/25C/A	-	8,3	4,8	4	5,5	17	16,9	16,8	16,7	16,6	16,3	15,9	15,4	14,8	13,9	12,7	11,1	9,3	7,2	-	-	
-	NM4 80/25B/B	-	12,5	7,2	5,5	7,5	20,8	20,7	20,7	20,6	20,5	20,3	20	19,6	19,1	18,2	17,1	15,4	13,5	11,4	9	-	-
-	NM4 80/25A/B	-	16	9,2	7,5	10	23,8	23,7	23,7	23,6	23,5	23,3	23	22,7	22,2	21,5	20,5	19	17,2	15,1	12,7	-	-
BNM4	NM4 80/31C/B	-	20,5	11,8	9,2	12,5	24,3	25,7	25,8	25,8	25,8	25,6	25,4	25,1	24,4	23,6	22,2	20,4	18,3	15,9	-	-	-
-	NM4 80/31B	-	22,5	13	11	15	28,5	30,3	30,5	30,6	30,7	30,7	30,5	30,2	29,6	28,8	27,5	25,9	24,1	22	-	-	-
-	NM4 80/31A	-	29	16,7	15	20	34,5	36,3	36,4	36,5	36,5	36,6	36,5	36,3	36,1	35,7	35	33,9	32,5	30,9	28,9	25,4	-
BNMS4	NMS4 80/315S	-	-	-	18,5	25	38	39,1	39,2	39,3	39,4	39,5	39,4	39,3	39,2	38,7	38,1	37,1	35,7	34,1	32,1	28,3	22,5
BNMS4	NMS4 80/400C/B	-	-	-	18,5	25	42	42,8	42,8	42,9	42,9	42,7	42,5	42,2	41,8	40,9	39,8	37,9	35,4	32,5	29	-	-
BNMS4	NMS4 80/400B/B	-	-	-	22	30	47	48,2	48,2	48,2	48,2	48,1	47,9	47,7	47,3	46,6	45,7	44,1	42,1	39,5	36,3	30,5	-
BNMS4	NMS4 80/400A/B	-	-	-	30	40	60	61,4	61,5	61,5	61,6	61,5	61,5	61,3	61,1	60,7	60,1	59	57,6	55,8	53,6	49,5	-
BNMS4	NMS4 80/400S	-	-	-	37	50	60	61,4	61,5	61,5	61,6	61,5	61,3	61,1	60,7	60,1	59	57,6	55,8	53,7	49,5	43,9	39,2

P2: Rated motor power output.

H: Total head in m

Tolerances according to UNI EN ISO 9906:2012

## Performance n ≈ 1450 rpm

### Three-phase

Model		Voltage				P2		Q = Flow																
		230V	400V	690V				m³/h	0															
								l/min	48	54	60	66	75	84	96	108	120	132	150	168	180	192	210	
		A		kW	HP	H (m) = Total head																		
BNM4	NM4 100/20C/A	11,1	6,4	-	3	4		9,4	9,4	9,3	9,2	9,1	8,8	8,5	8	7,3	6,5	5,6	4	-	-	-	-	
BNM4	NM4 100/20B/A	-	8,3	4,8	4	5,5		12	12	11,9	11,8	11,7	11,5	11,2	10,7	10,1	9,3	8,4	6,7	4,5	-	-	-	
BNM4	NM4 100/20A/C	-	12,5	7,2	5,5	7,5		15,1	15,2	15,2	15,1	15,1	14,9	14,7	14,3	13,7	13,1	12,2	10,8	8,9	7,5	6	-	
-	NM4 100/25B/B	-	16	9,2	7,5	10		19,3	19,5	19,5	19,4	19,3	19,1	18,7	18,2	17,5	16,6	15,6	13,8	11,7	10,1	8,4	5,5	
-	NM4 100/25A/B	-	20,5	11,8	9,2	12,5		22,1	22,3	22,3	22,2	22,1	21,9	21,7	21,2	20,5	19,8	18,8	17,1	15	13,4	11,7	8,9	
-	NM4 100/31C	-	22,5	13	11	15		27	26,9	26,8	26,7	26,5	26,2	25,7	24,9	23,9	22,7	21,3	18,8	15,9	13,7	11,3	-	
-	NM4 100/31B	-	29	16,7	15	20		31,5	31,5	31,5	31,5	31,4	31,2	30,8	30,2	29,3	28,2	26,9	24,6	21,9	19,8	17,6	14	
BNMS4	NMS4 100/315A/A	-	-	-	18,5	25		36,8	36,8	36,9	36,9	36,9	36,7	36,4	35,9	35,2	34,4	33,3	31,4	29,1	27,3	25,4	22,1	
BNMS4	NMS4 100/400C/A	-	-	-	22	30		41,5	41,3	41,2	41,2	41	40,8	40,4	39,8	38,9	37,8	36,5	34,1	31,1	28,7	26	-	
BNMS4	NMS4 100/400B/A	-	-	-	30	40		50	50,2	50,1	50,1	49,9	49,7	49,4	48,8	48	47,1	46	43,9	41,4	39,4	37,2	33,4	
BNMS4	NMS4 100/400A/A	-	-	-	37	50		58	58,2	58,1	58,1	58	57,8	57,6	57	56,4	55,5	54,6	52,8	50,6	48,9	47,1	44	

### Three-phase

Model		Voltage				P2		Q = Flow																
		400V	690V					m³/h	0															
								l/min	84	96	108	120	132	150	168	180	192	210	240	270	300	330		
		A		kW	HP	H (m) = Total head																		
-	NM4 125/25E/B	12,5	7,2	5,5	7,5			11	11	10,8	10,5	10,1	9,7	9,1	8,3	7,8	7,2	6,2	4,4	-	-	-		
-	NM4 125/25D/B	16	9,2	7,5	10			14	14	13,9	13,7	13,4	13	12,4	11,6	11	10,4	9,4	7,4	5,1	-	-		
-	NM4 125/25C/B	20,5	11,8	9,2	12,5			16,7	16,7	16,6	16,5	16,2	15,9	15,4	14,6	14,1	13,5	12,4	10,5	8,2	5,8	-		
-	NM4 125/25B	22,5	13	11	15			19,1	19,3	19,2	19,1	18,9	18,7	18,2	17,5	16,9	16,3	15,3	13,3	10,9	8,2	-		
-	NM4 125/25A	29	16,7	15	20			22,8	22,7	22,7	22,6	22,4	22,2	21,8	21,2	20,7	20,2	19,3	17,4	15,1	12,4	9,3		
BNMS4	NMS4 125/315C/A	-	-	18,5	25			28	27,9	27,9	27,7	27,5	27,2	26,5	25,6	24,9	24,1	22,8	20,1	17	13,5	9,5		
BNMS4	NMS4 125/315B/A	-	-	22	30			31,9	31,8	31,7	31,6	31,4	31,1	30,5	29,8	29,2	28,5	27,3	24,9	22	18,4	14,3		
BNMS4	NMS4 125/315A/A	-	-	30	40			36,4	36,8	36,8	36,7	36,6	36,4	35,9	35,2	34,7	34,2	33,2	31	28,4	25,3	21,6		
BNMS4	NMS4 125/400C/A	-	-	37	50			45,5	45,3	45,5	45,5	45,3	45,1	44,4	43,5	42,7	41,8	40,2	37	33,1	28,6	23,4		
BNMS4	NMS4 125/400B/A	-	-	45	60			51,8	51,4	51,3	51,2	51,1	50,9	50,4	49,7	49	48,2	46,8	44	40,5	36	31,5		
BNMS4	NMS4 125/400A/A	-	-	55	75			59,2	59,2	59,1	59,1	58,9	58,7	58,3	57,7	57,2	56,6	55,6	53,4	50,5	46,8	42,3		

### Three-phase

Model		Voltage				P2		Q = Flow																
								m³/h	0															
								l/min	132	150	168	180	192	210	240	270	300	330	360	390	420	450	480	540
		kW		HP	H (m) = Total head																			
BNMS4	NMS4 150/315D/B	18,5	25		22,4	23,1	22,8	22,5	22,2	21,9	21,3	20,3	19,1	17,8	16,4	15	13,5	11,9	10,2	-	-	-	-	
BNMS4	NMS4 150/315C/B	22	30		25,9	26,7	26,4	26,1	25,8	25,4	24,9	23,8	22,5	21	19,5	17,9	16,2	14,5	12,7	10,8	-	-	-	
BNMS4	NMS4 150/315B/B	30	40		24	25,3	25,2	25,1	25	24,9	24,7	24,3	23,8	23,2	22,4	21,6	20,8	19,8	18,7	17,6	15,1	-	-	
BNMS4	NMS4 150/315A/B	37	50		28	29,5	29,5	29,5	29,5	29,4	29,3	29	28,6	28,1	27,5	26,7	25,9	24,9	23,8	22,6	19,9	16,7	-	
BNMS4	NMS4 150/315S	45	60		33,5	34,9	34,9	34,9	34,9	34,8	34,7	34,5	34,1	33,6	33	32,2	31,4	30,4	29,4	28,2	25,5	22,3	18,7	
BNMS4	NMS4 150/400B/B	55	75		39	42,2	42,3	42,3	42,2	42,2	42	41,6	41	40,3	39,5	38,6	37,5	36,4	35	33,5	29,8	25,4	-	
BNMS4	NMS4 150/400A/B	75	100		50	52,5	52,6	52,6	52,6	52,5	52,4	52,2	51,8	51,3	50,6	49,6	48,5	47,2	45,8	44,2	40,6	36,7	32,2	
BNMS4	NMS4 150/400S	90	120		58,6	60,8	60,9	61	61	61	61	60,7	60,3	59,6	58,8	57,7	56,4	54,9	53,2	51,4	47,3	42,7	37,6	

**P2:** Rated motor power output.

**H:** Total head in m

Tolerances according to UNI EN ISO 9906:2012

**Performance n ≈ 1450 rpm**

**Rated current**

Motor P2	IE3			IE4		
	400V	690V	la/In	400V	690V	la/In
0.37	0.95	-	4.2	-	-	-
0.55	1.5	-	4.8	-	-	-
0.75	1.9	-	7.2	1.7	-	7.3
1.1	2.9	-	6.6	2.4	-	7.5
1.5	3.5	-	8.3	3.2	-	7.6
2.2	5	-	8.6	4.6	-	7.5
3	6.4	-	5.8	6.1	-	7.4
4	8.3	4.8	7.2	8.1	4.7	7.6
5.5	12.5	7.2	7.2	10.9	6.3	7.5
7.5	16	9.2	7.1	14.6	8.5	7.7
9.2	20.5	11.8	7.4	-	-	-
11	22.5	13	9.6	20.5	11.9	9.5
15	29	16.7	9.1	27.4	15.9	9.5
18.5	35	20.5	7.2	33.3	19.3	9.5
22	41	24	6.8	39.5	22.9	9.5
30	55	32	7.3	53.7	31.1	9
37	66	38.5	6.4	66	38.3	9
45	80	46.5	6.4	80.1	46.4	9
55	96	56	6.8	96.5	55.9	9
75	133	77	6.9	129.6	75.1	8.5
90	-	-	-	153.6	89	8.5

**A\*:** Calpeda motor Standard

**la/In** D.O.L. starting current / Nominal current

## Coverage chart $n \approx 1450$ rpm

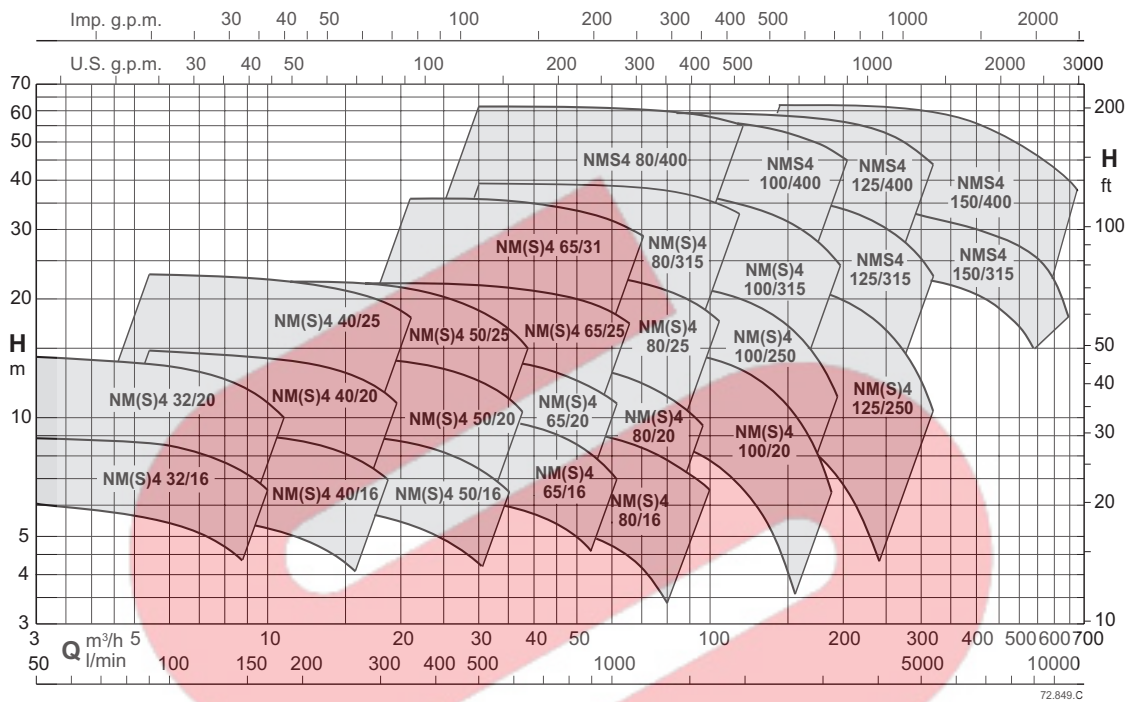

## Performance $n \approx 1450$ rpm

### Three-phase

Model		P2		Q = Flow														
				m³/h	0	2,4	3	3,6	4,2	4,8	5,4	6	7,5	8,4	9,6	10,8	12	13,2
				l/min	40	50	60	70	80	90	100	125	140	160	180	200	220	
BNMS4	NMS4 32/200A	0,75	1		14,2	14,3	14,2	14,2	14,1	13,9	13,7	13,5	12,8	12,2	11,3	10,3	9	7,4

### Three-phase

Model		P2		Q = Flow																
				m³/h	0	5,4	6	7,5	8,4	9,6	10,8	12	13,2	15	16,8	18,9	21	24	27	30
				l/min	90	100	125	140	160	180	200	220	250	280	315	350	400	450	500	
BNMS4	NMS4 40/160A	0,75	1		9,4	9,6	9,6	9,6	9,4	9,3	9,1	9	8,8	8,4	7,9	7,2	6,4	5,1	3,5	-
BNMS4	NMS4 40/200B	1,1	1,5		13	13	12,9	12,7	12,6	12,4	12,2	12	11,5	10,8	10	8,6	7	-	-	-
BNMS4	NMS4 40/200A	1,1	1,5		14,9	14,8	14,7	14,5	14,4	14,2	14	13,8	13,6	13	12,2	11,3	10	-	-	-
BNMS4	NMS4 40/250C	1,5	2		17,2	17,4	17,3	17,2	17	16,8	16,6	16,3	16	15,1	13,8	12,1	10,4	7,2	2,8	-
BNMS4	NMS4 40/250B	2,2	3		21,4	21,4	21,5	21,3	21,2	21	20,9	20,8	20,5	20	19,5	18,3	16,4	13,3	10	5
BNMS4	NMS4 40/250A	3	4		22,8	22,9	22,8	22,9	22,8	22,5	22,5	22,2	22	21,8	21,4	20,4	18,9	16	12,6	8

**P2:** Rated motor power output.

**H:** Total head in m

Tolerances according to UNI EN ISO 9906:2012

## Performance n ≈ 1450 rpm

### Three-phase

Model		P2		Q = Flow														
				m³/h	0	10,8	12	13,2	15	16,8	18,9	21	24	27	30	33	37,8	42
				l/min	180	200	220	250	280	315	350	400	450	500	550	630	700	800
		kW	HP	H (m) = Total head														
BNMS4	NMS4 50/160B	1,1	1,5	8	8,2	8,2	8,2	8,1	8	7,8	7,6	7,2	6,7	6,2	5,5	4,4	3,3	-
BNMS4	NMS4 50/160A	1,1	1,5	9,5	9,6	9,6	9,6	9,5	9,5	9,3	9,1	8,8	8,3	7,8	7,2	6,1	4,9	3,1
BNMS4	NMS4 50/200C	1,1	1,5	11,3	11,8	11,8	11,7	11,7	11,5	11,3	10,9	10,4	9,8	9	8,1	6,3	4,7	-
BNMS4	NMS4 50/200B	1,5	2	13	13,4	13,4	13,4	13,3	13,1	12,9	12,6	12,1	11,5	10,8	9,9	8,2	6,4	3,7
BNMS4	NMS4 50/200A	2,2	3	14,4	14,9	14,9	14,9	14,9	14,8	14,6	14,4	14	13,4	12,8	12	10,4	8,6	6
BNMS4	NMS4 50/250C	2,2	3	17,2	17,8	17,8	17,7	17,5	17,2	16,8	16,4	15,7	14,9	13,8	12,4	9,7	6,8	-
BNMS4	NMS4 50/250D	2,2	3	14,5	14,5	14,4	14,3	14	13,7	13,4	13	12,2	11,2	9,7	8,1	5,4	2,3	-
BNMS4	NMS4 50/250B	3	4	20,2	20,7	20,7	20,7	20,6	20,4	20	19,5	18,9	18,2	17,1	15,9	13,2	10,6	5,8
BNMS4	NMS4 50/250A	4	5,5	24,2	22,7	22,7	22,6	22,5	22,4	22,1	21,6	21	20,2	19,4	18,3	16,4	13,6	9

### Three-phase

Model		P2		Q = Flow														
				m³/h	0	21	24	27	30	33	37,8	42	48	54	60	66	75	84
				l/min	350	400	450	500	550	630	700	800	900	1000	1100	1250	1400	1600
		kW	HP	H (m) = Total head														
BNMS4	NMS4 65/160C	1,1	1,5	6,4	6,1	6,1	6	6	5,9	5,8	5,6	5,3	4,8	4,2	-	-	-	-
BNMS4	NMS4 65/160B	1,1	1,5	7,4	7,2	7,1	7,1	7	7	6,8	6,6	6,3	5,8	5,2	4,5	-	-	-
BNMS4	NMS4 65/160A	1,5	2	8,8	8,8	8,8	8,7	8,7	8,6	8,5	8,3	8	7,6	7,1	6,4	5,2	-	-
BNMS4	NMS4 65/160S	2,2	3	9,9	10,2	10,2	10,1	10,1	10	9,9	9,7	9,4	9,1	8,6	8	7	5,7	-
BNMS4	NMS4 65/200B	2,2	3	11,1	11,7	11,7	11,6	11,6	11,5	11,3	11	10,6	10,1	9,5	8,7	7,4	5,8	3,3
BNMS4	NMS4 65/200A	3	4	13,8	14,2	14,2	14,2	14,1	14,1	13,9	13,7	13,4	13	12,5	11,8	10,7	9,3	7
BNMS4	NMS4 65/250B	4	5,5	16,5	17,9	18	18	18	18	17,8	17,5	17	16,3	15,4	14,4	12,5	10,4	7
BNMS4	NMS4 65/250A	5,5	7,5	21	22,2	22,3	22,4	22,4	22,4	22,2	22	21,6	21	20,2	19,3	17,6	15,7	12,6
BNMS4	NMS4 65/315C	5,5	7,5	26	25,8	25,7	25,5	25,3	25	24,4	23,8	22,8	21,5	20	18,2	15	11	-
BNMS4	NMS4 65/315B	7,5	10	31	31	31	30,9	30,8	30,6	30,2	29,7	28,8	27,8	26,5	25	22,2	18,6	-
BNMS4	NMS4 65/315A	11	15	36	35,9	35,9	35,8	35,7	35,5	35,1	34,6	33,8	32,8	31,6	30,2	27,8	25	-

### Three-phase

Model		P2		Q = Flow																		
				m³/h	0	30	33	37,8	42	48	54	60	66	75	84	96	108	120	132	150	168	180
				l/min	500	550	630	700	800	900	1000	1100	1250	1400	1600	1800	2000	2200	2500	2800	3000	
		kW	HP	H (m) = Total head																		
BNMS4	NMS4 80/160C	1,1	1,5	6,5	6,1	6,1	5,9	5,8	5,5	5,2	4,9	4,6	4	3,3	-	-	-	-	-	-	-	-
BNMS4	NMS4 80/160B	1,5	2	8,2	7,8	7,7	7,6	7,5	7,3	7	6,8	6,4	5,9	5,2	4,1	-	-	-	-	-	-	-
BNMS4	NMS4 80/160A	2,2	3	10,1	10	10	9,9	9,8	9,7	9,5	9,3	9	8,5	8	7	5,9	-	-	-	-	-	-
BNMS4	NMS4 80/200C	2,2	3	8,7	9	9	8,9	8,8	8,7	8,5	8,2	7,9	7,4	6,8	5,7	4,3	2,7	-	-	-	-	-
BNMS4	NMS4 80/200B	3	4	11,2	11,7	11,7	11,7	11,6	11,5	11,3	11,1	10,8	10,3	9,7	8,7	7,4	5,9	-	-	-	-	-
BNMS4	NMS4 80/200A	4	5,5	13,8	14,2	14,2	14,1	14	13,9	13,7	13,5	13,2	12,7	12,1	11,1	9,9	8,5	6,9	-	-	-	-
BNMS4	NMS4 80/250C	4	5,5	17	16,9	16,8	16,7	16,6	16,3	15,9	15,4	14,8	13,9	12,7	11,1	9,3	7,2	-	-	-	-	-
BNMS4	NMS4 80/250B	5,5	7,5	20,8	20,7	20,7	20,6	20,5	20,3	20	19,6	19,1	18,2	17,1	15,4	13,5	11,4	9	-	-	-	-
BNMS4	NMS4 80/250A	7,5	10	23,8	23,7	23,7	23,6	23,5	23,3	23	22,7	22,2	21,5	20,5	19	17,2	15,1	12,7	-	-	-	-
BNMS4	NMS4 80/315C	11	15	24,2	25,7	25,8	25,8	25,8	25,8	25,6	25,4	25,1	24,4	23,6	22,2	20,4	18,3	15,9	-	-	-	-
BNMS4	NMS4 80/315B/A	11	15	28,3	30,3	30,5	30,6	30,7	30,7	30,7	30,5	30,2	29,6	28,8	27,5	25,9	24,1	22	-	-	-	-
BNMS4	NMS4 80/315A	15	20	34,8	36,3	36,4	36,5	36,5	36,6	36,5	36,3	36,1	35,7	35	33,9	32,5	30,9	28,9	25,4	-	-	-
BNMS4	NMS4 80/315S	18,5	25	38	39,1	39,2	39,3	39,4	39,5	39,4	39,3	39,2	38,7	38,1	37,1	35,7	34,1	32,1	28,3	22,5	-	-
BNMS4	NMS4 80/400C/B	18,5	25	42	42,8	42,8	42,9	42,9	42,7	42,5	42,2	41,8	40,9	39,8	37,9	35,4	32,5	29	-	-	-	-
BNMS4	NMS4 80/400B/B	22	30	47	48,2	48,2	48,2	48,2	48,1	47,9	47,7	47,3	46,6	45,7	44,1	42,1	39,5	36,3	30,5	-	-	-
BNMS4	NMS4 80/400A/B	30	40	60	61,4	61,5	61,5	61,6	61,5	61,5	61,3	61,1	60,7	60,1	59	57,6	55,8	53,6	49,5	-	-	-
BNMS4	NMS4 80/400S	37	50	60	61,4	61,5	61,5	61,6	61,6	61,5	61,3	61,1	60,7	60,1	59	57,6	55,8	53,7	49,5	43,9	39,2	-

**P2:** Rated motor power output.

**H:** Total head in m

Tolerances according to UNI EN ISO 9906:2012

## Performance n ≈ 1450 rpm

### Three-phase

		P2		Q = Flow															
				m³/h	0	48	54	60	66	75	84	96	108	120	132	150	168	180	192
Model		kW	HP	l/min	800	900	1000	1100	1250	1400	1600	1800	2000	2200	2500	2800	3000	3200	3500
				H (m) = Total head															
BNMS4	NMS4 100/200C	3	4	9,3	9,4	9,3	9,2	9,1	8,8	8,5	8	7,3	6,5	5,6	4	-	-	-	-
BNMS4	NMS4 100/200B	4	5,5	12	12	11,9	11,8	11,7	11,5	11,2	10,7	10,1	9,3	8,4	6,7	4,5	-	-	-
BNMS4	NMS4 100/200A	5,5	7,5	15,1	15,2	15,2	15,1	15,1	14,9	14,7	14,3	13,7	13,1	12,2	10,8	8,9	7,5	6	-
BNMS4	NMS4 100/250B	7,5	10	19,3	19,5	19,5	19,4	19,3	19,1	18,7	18,2	17,5	16,6	15,6	13,8	11,7	10,1	8,4	5,5
BNMS4	NMS4 100/250A/A	11	15	22,1	22,3	22,3	22,2	22,1	21,9	21,7	21,2	20,5	19,8	18,8	17,1	15	13,4	11,7	8,9
BNMS4	NMS4 100/315C/A	11	15	26,8	26,9	26,8	26,7	26,5	26,2	25,7	24,9	23,9	22,7	21,3	18,8	15,9	13,7	11,3	-
BNMS4	NMS4 100/315B/A	15	20	31,8	31,5	31,5	31,5	31,4	31,2	30,8	30,2	29,3	28,2	26,9	24,6	21,9	19,8	17,6	14
BNMS4	NMS4 100/315A/A	18,5	25	36,8	36,8	36,9	36,9	36,9	36,7	36,4	35,9	35,2	34,4	33,3	31,4	29,1	27,3	25,4	22,1
BNMS4	NMS4 100/400C/A	22	30	41,5	41,3	41,2	41,2	41	40,8	40,4	39,8	38,9	37,8	36,5	34,1	31,1	28,7	26	-
BNMS4	NMS4 100/400B/A	30	40	50	50,2	50,1	50,1	49,9	49,7	49,4	48,8	48	47,1	46	43,9	41,4	39,4	37,2	33,4
BNMS4	NMS4 100/400A/A	37	50	58	58,2	58,1	58,1	58	57,8	57,6	57	56,4	55,5	54,6	52,8	50,6	48,9	47,1	44

### Three-phase

		P2		Q = Flow														
				m³/h	0	84	96	108	120	132	150	168	180	192	210	240	270	300
Model		kW	HP	l/min	1400	1600	1800	2000	2200	2500	2800	3000	3200	3500	4000	4500	5000	5500
				H (m) = Total head														
BNMS4	NMS4 125/250E	5,5	7,5	11	11	10,8	10,5	10,1	9,7	9,1	8,3	7,8	7,2	6,2	4,4	-	-	-
BNMS4	NMS4 125/250D	7,5	10	14	14	13,9	13,7	13,4	13	12,4	11,6	11	10,4	9,4	7,4	5,1	-	-
BNMS4	NMS4 125/250C/A	11	15	16,8	16,7	16,6	16,5	16,2	15,9	15,4	14,6	14,1	13,5	12,4	10,5	8,2	5,8	-
BNMS4	NMS4 125/250B/A	11	15	19,1	19,3	19,2	19,1	18,9	18,7	18,2	17,5	16,9	16,3	15,3	13,3	10,9	8,2	-
BNMS4	NMS4 125/250A/A	15	20	22,8	22,7	22,7	22,6	22,4	22,2	21,8	21,2	20,7	20,2	19,3	17,4	15,1	12,4	9,3
BNMS4	NMS4 125/315C/A	18,5	25	28	27,9	27,9	27,7	27,5	27,2	26,5	25,6	24,9	24,1	22,8	20,1	17	13,5	9,5
BNMS4	NMS4 125/315B/A	22	30	31,9	31,8	31,7	31,6	31,4	31,1	30,5	29,8	29,2	28,5	27,3	24,9	22	18,4	14,3
BNMS4	NMS4 125/315A/A	30	40	36,4	36,8	36,8	36,7	36,6	36,4	35,9	35,2	34,7	34,2	33,2	31	28,4	25,3	21,6
BNMS4	NMS4 125/400C/A	37	50	45,5	45,3	45,5	45,5	45,3	45,1	44,4	43,5	42,7	41,8	40,2	37	33,1	28,6	23,4
BNMS4	NMS4 125/400B/A	45	60	51,8	51,4	51,3	51,2	51,1	50,9	50,4	49,7	49	48,2	46,8	44	40,5	36	31,5
BNMS4	NMS4 125/400A/A	55	75	59,2	59,2	59,1	59,1	58,9	58,7	58,3	57,7	57,2	56,6	55,6	53,4	50,5	46,8	42,3

### Three-phase

		P2		Q = Flow																		
				m³/h	0	132	150	168	180	192	210	240	270	300	330	360	390	420	450	480	540	600
Model		kW	HP	l/min	2200	2500	2800	3000	3200	3500	4000	4500	5000	5500	6000	6500	7000	7500	8000	9000	10000	11000
				H (m) = Total head																		
BNMS4	NMS4 150/315D/B	18,5	25	22,4	23,1	22,8	22,5	22,2	21,9	21,3	20,3	19,1	17,8	16,4	15	13,5	11,9	10,2	-	-	-	-
BNMS4	NMS4 150/315C/B	22	30	25,9	26,7	26,4	26,1	25,8	25,4	24,9	23,8	22,5	21	19,5	17,9	16,2	14,5	12,7	10,8	-	-	-
BNMS4	NMS4 150/315B/B	30	40	24	25,3	25,2	25,1	25	24,9	24,7	24,3	23,8	23,2	22,4	21,6	20,8	19,8	18,7	17,6	15,1	-	-
BNMS4	NMS4 150/315A/B	37	50	28	29,5	29,5	29,5	29,5	29,4	29,3	29	28,6	28,1	27,5	26,7	25,9	24,9	23,8	22,6	19,9	16,7	-
BNMS4	NMS4 150/315S	45	60	33,5	34,9	34,9	34,9	34,8	34,7	34,5	34,1	33,6	33	32,2	31,4	30,4	29,4	28,2	25,5	22,3	18,7	-
BNMS4	NMS4 150/400B/B	55	75	39	42,2	42,3	42,3	42,2	42,2	42	41,6	41	40,3	39,5	38,6	37,5	36,4	35	33,5	29,8	25,4	-
BNMS4	NMS4 150/400A/B	75	100	50	52,5	52,6	52,6	52,5	52,4	52,2	51,8	51,3	50,6	49,6	48,5	47,2	45,8	44,2	40,6	36,7	32,2	-
BNMS4	NMS4 150/400S	90	120	58,6	60,8	60,9	61	61	61	61	60,7	60,3	59,6	58,8	57,7	56,4	54,9	53,2	51,4	47,3	42,7	37,6

**P2:** Rated motor power output.

**H:** Total head in m

Tolerances according to UNI EN ISO 9906:2012

## Performance $n \approx 1450$ rpm

### Rated current

Motor	IE3			IE4		
	400V	690V	la/In	400V	690V	la/In
P2	A	A		A	A	
kW	A	A	la/In	A	A	la/In
0.37	0.95	-	4.2	-	-	-
0.55	1.5	-	4.8	-	-	-
0.75	1.9	-	7.2	1.7	-	7.3
1.1	2.9	-	6.6	2.4	-	7.5
1.5	3.5	-	8.3	3.2	-	7.6
2.2	5	-	8.6	4.6	-	7.5
3	6.4	-	5.8	6.1	-	7.4
4	8.3	4.8	7.2	8.1	4.7	7.6
5.5	12.5	7.2	7.2	10.9	6.3	7.5
7.5	16	9.2	7.1	14.6	8.5	7.7
9.2	20.5	11.8	7.4	-	-	-
11	22.5	13	9.6	20.5	11.9	9.5
15	29	16.7	9.1	27.4	15.9	9.5
18.5	35	20.5	7.2	33.3	19.3	9.5
22	41	24	6.8	39.5	22.9	9.5
30	55	32	7.3	53.7	31.1	9
37	66	38.5	6.4	66	38.3	9
45	80	46.5	6.4	80.1	46.4	9
55	96	56	6.8	96.5	55.9	9
75	133	77	6.9	129.6	75.1	8.5
90	-	-	-	153.6	89	8.5

A\*: Calpeda motor Standard

la/In D.O.L. starting current / Nominal current

## Characteristic curves $n \approx 2900$ rpm

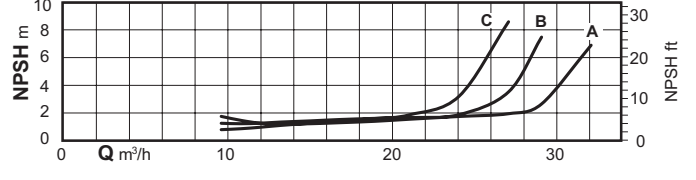
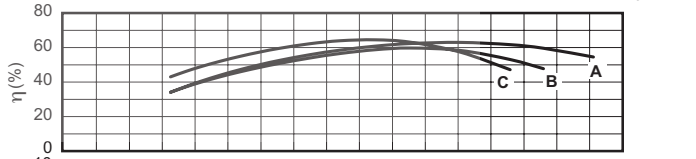
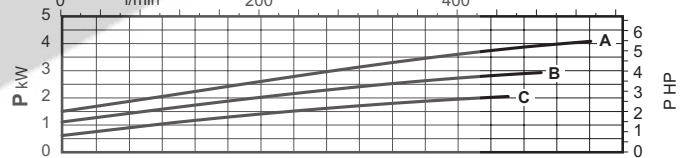
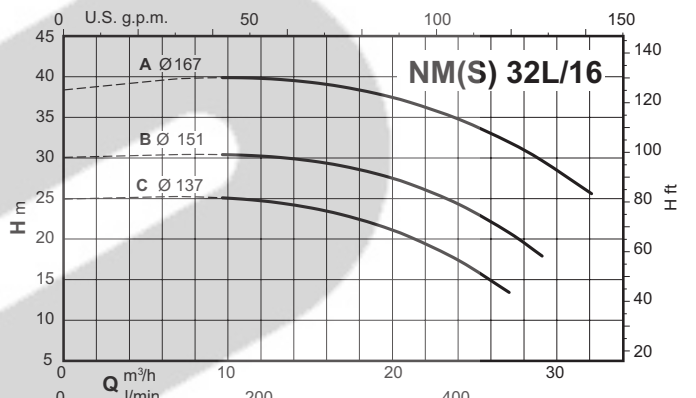
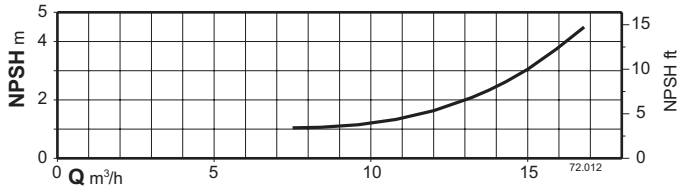
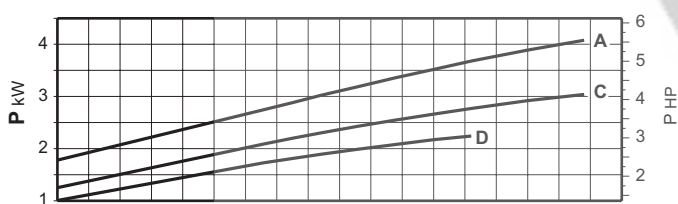
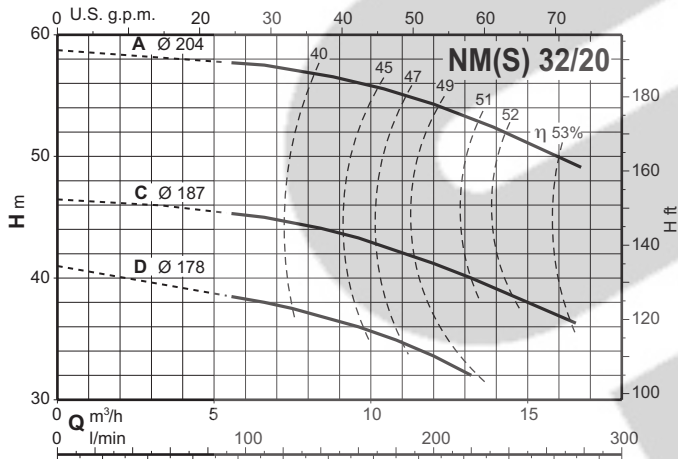
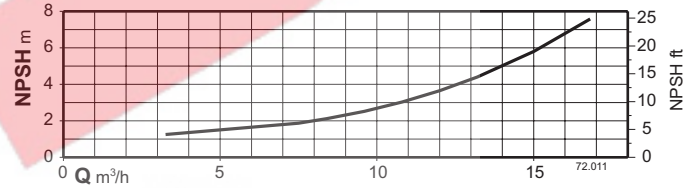
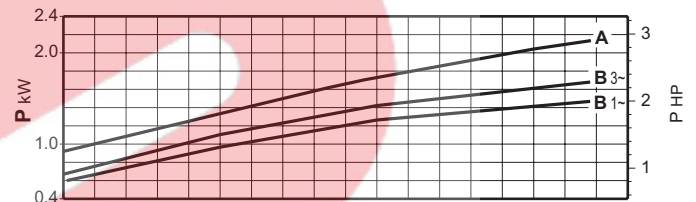
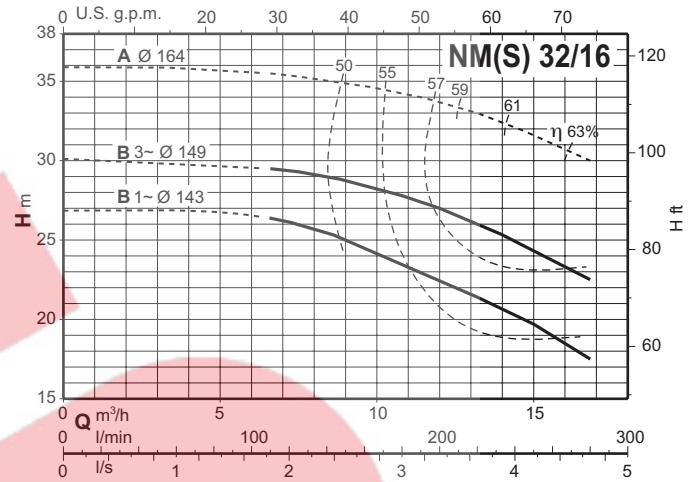
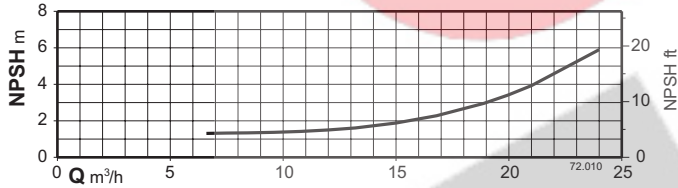
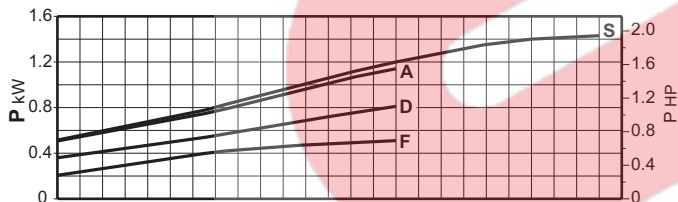
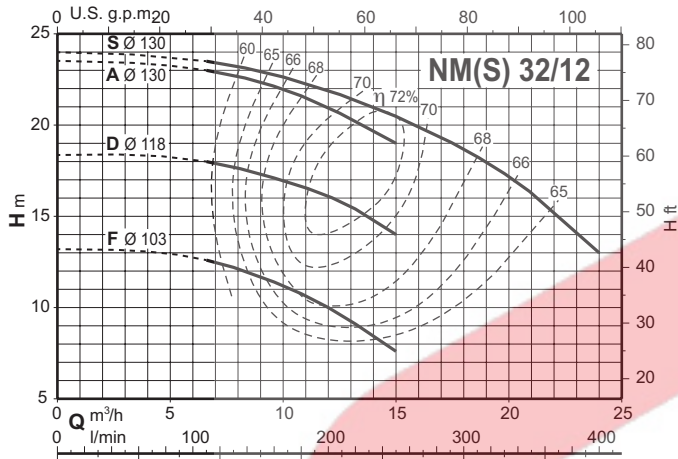

## Characteristic curves $n \approx 2900$ rpm

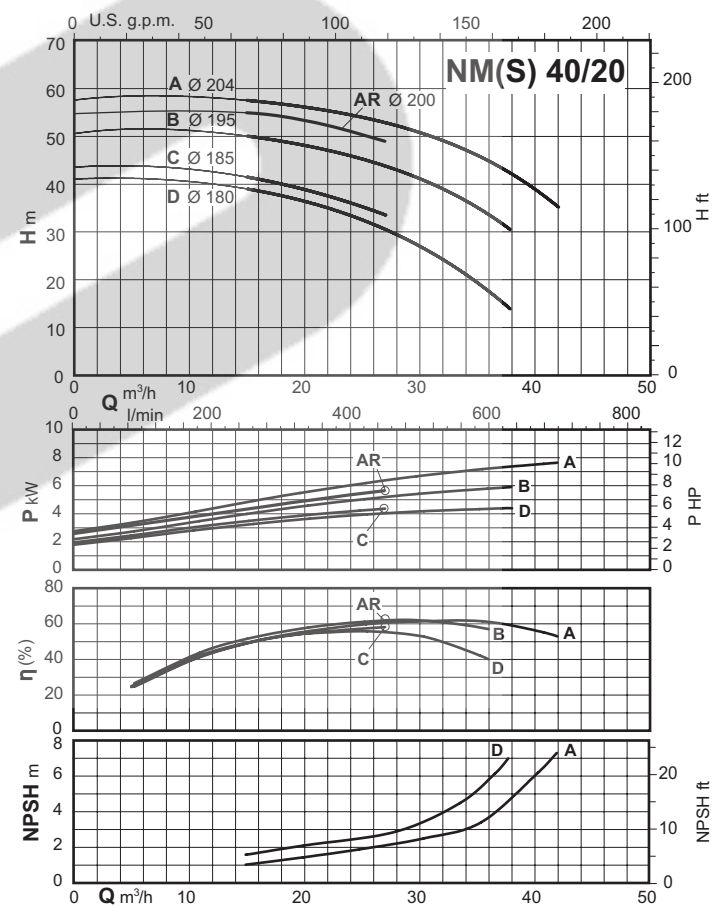
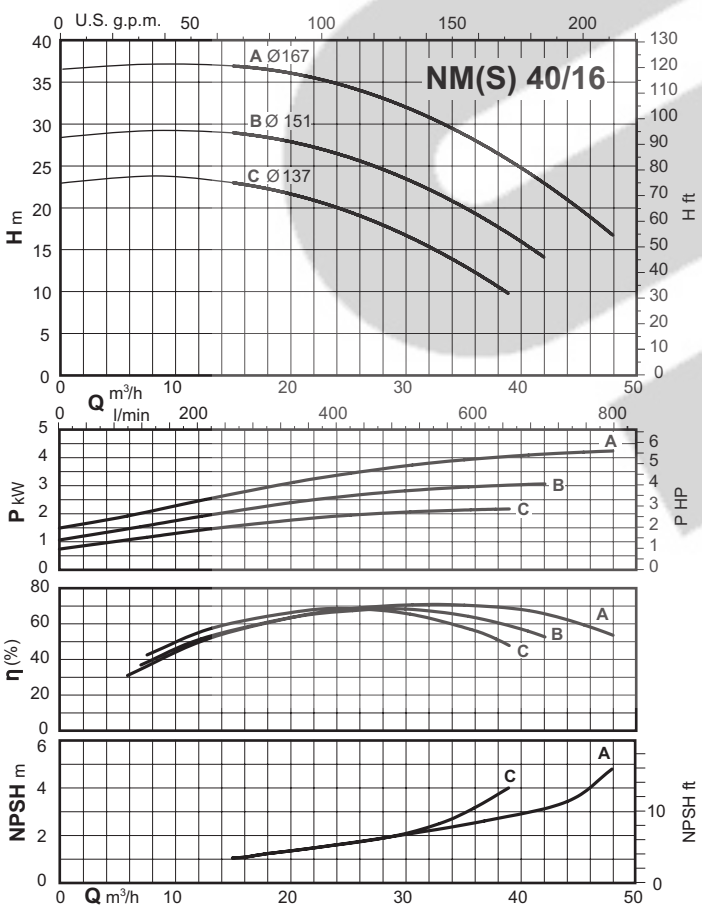
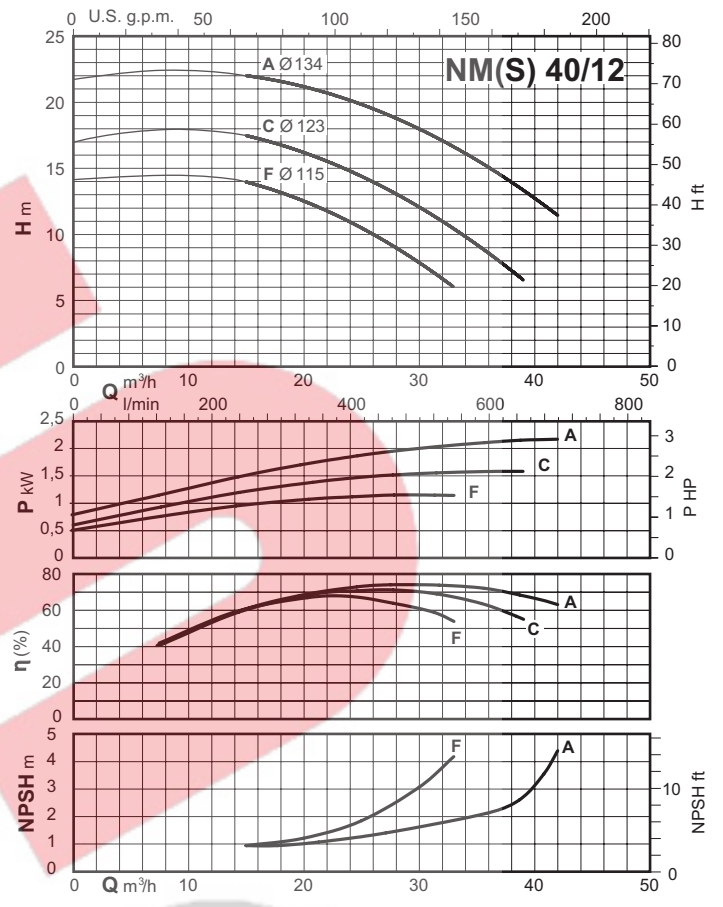
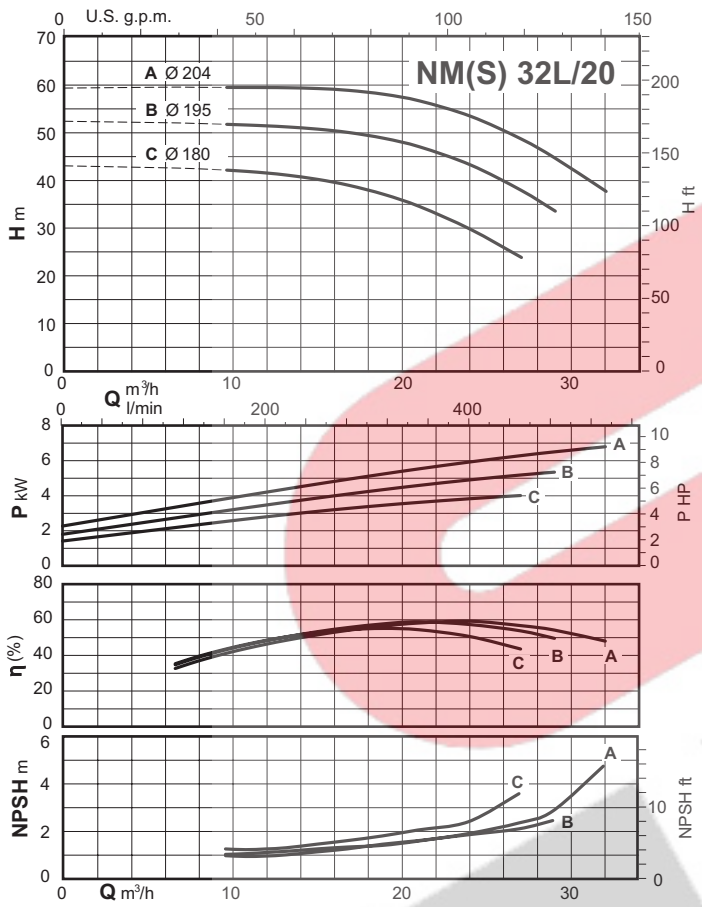

## Characteristic curves $n \approx 2900$ rpm

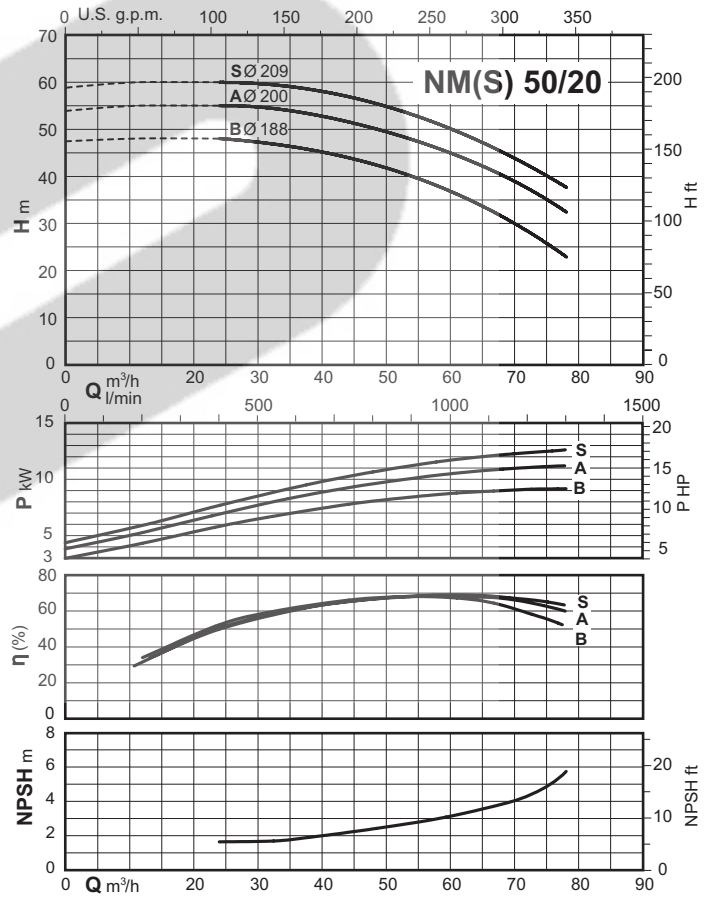
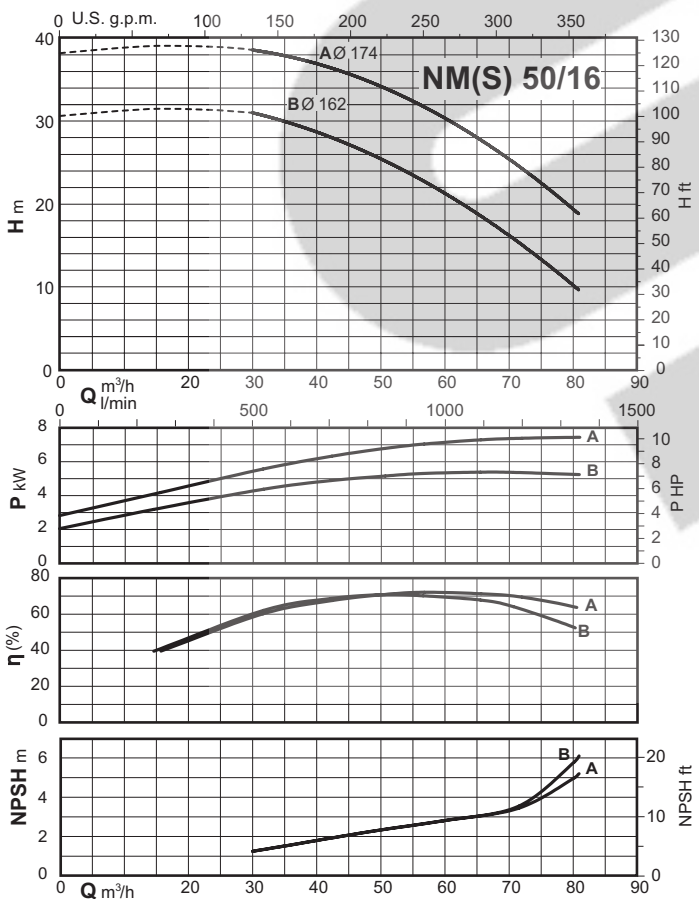
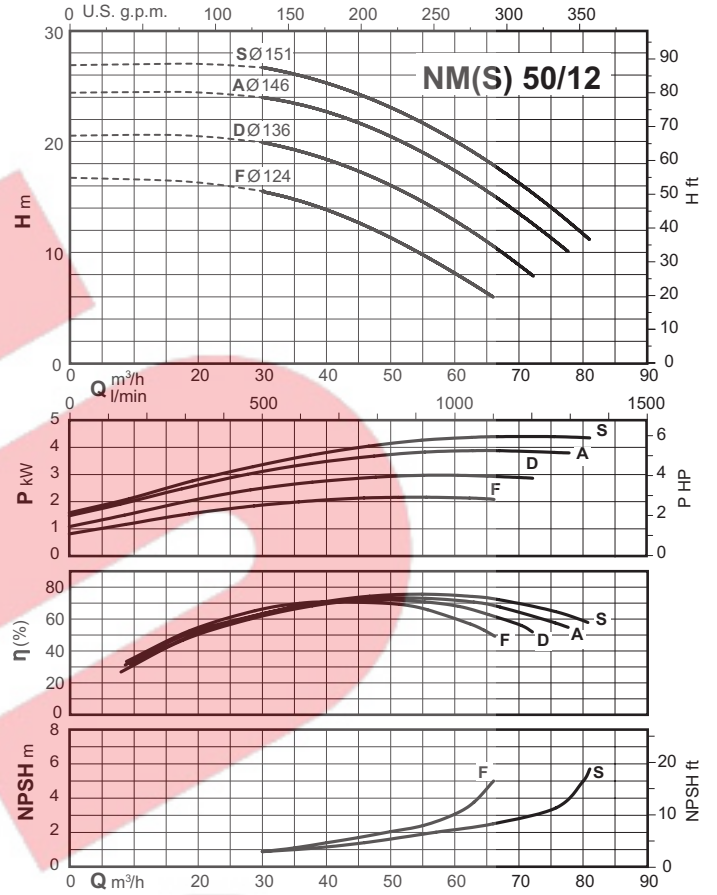
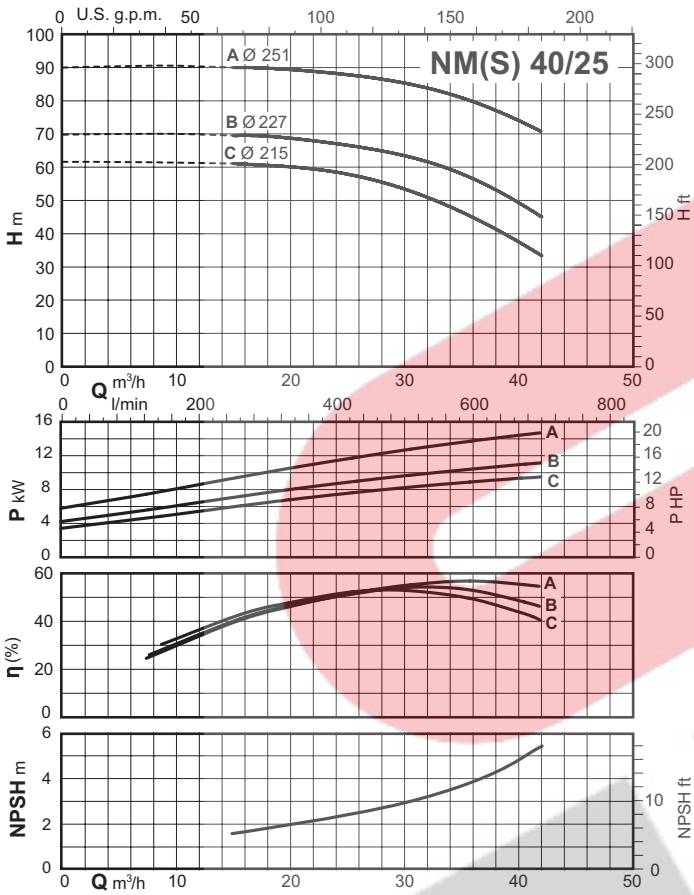

## Characteristic curves $n \approx 2900$ rpm

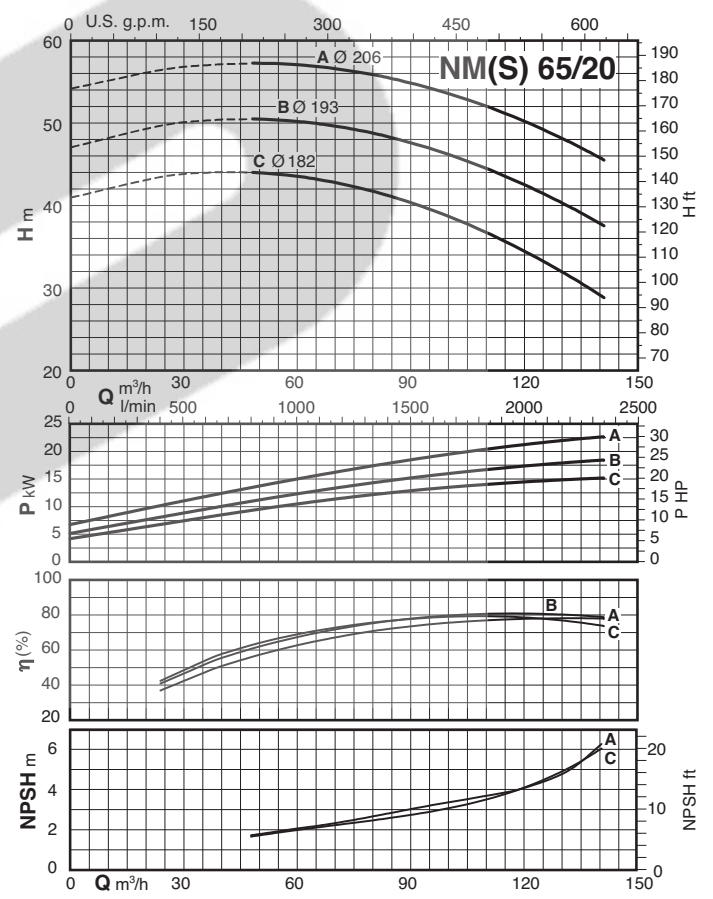
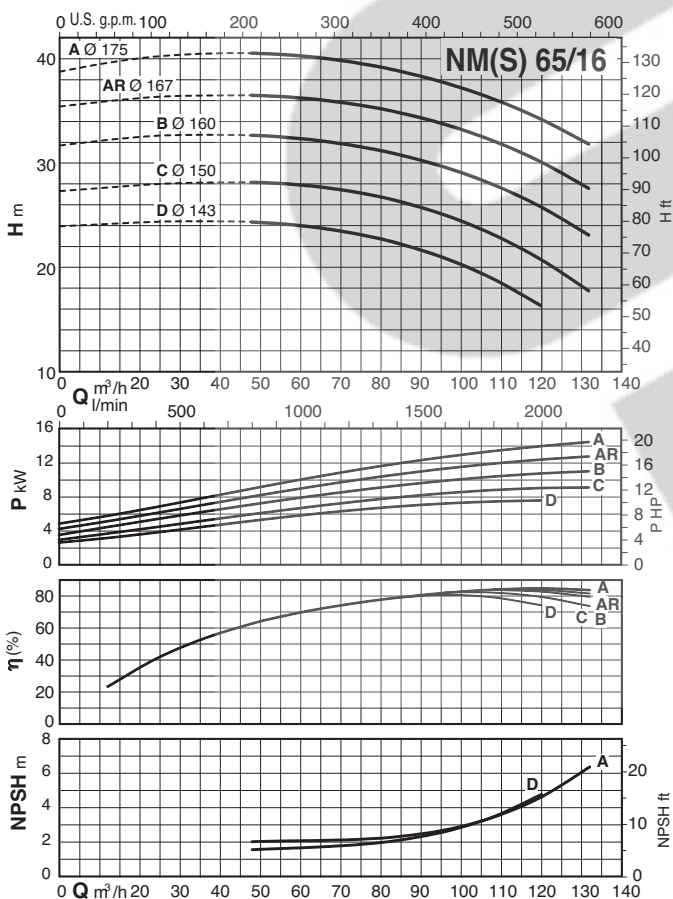
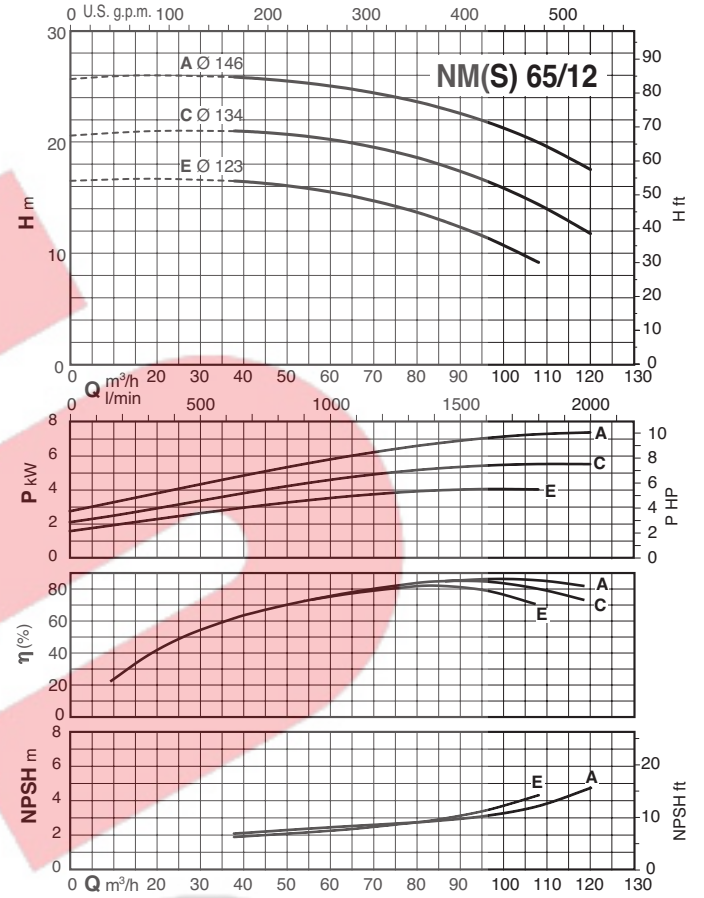
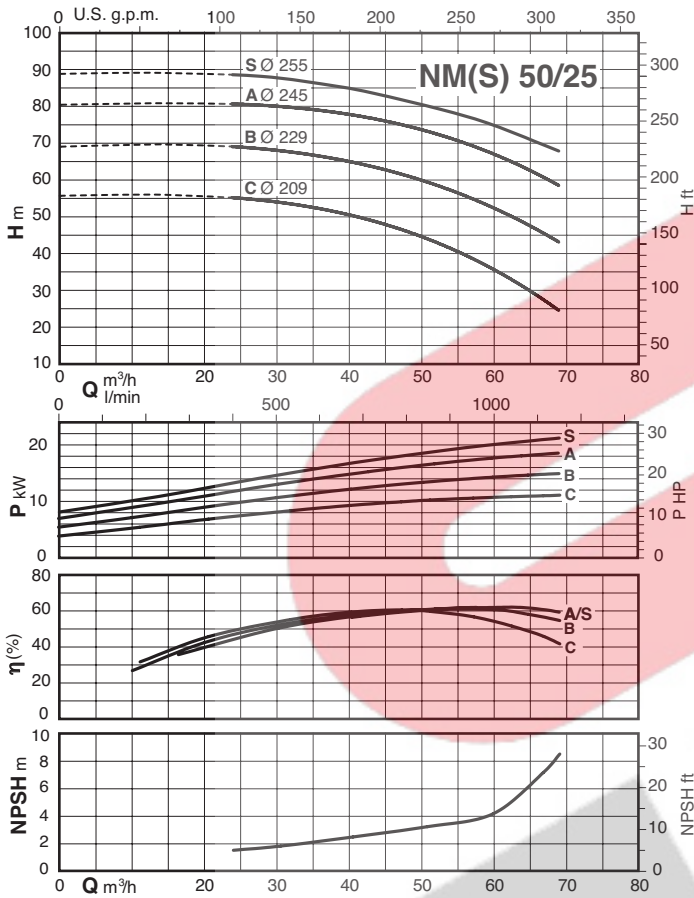

## Characteristic curves $n \approx 2900$ rpm

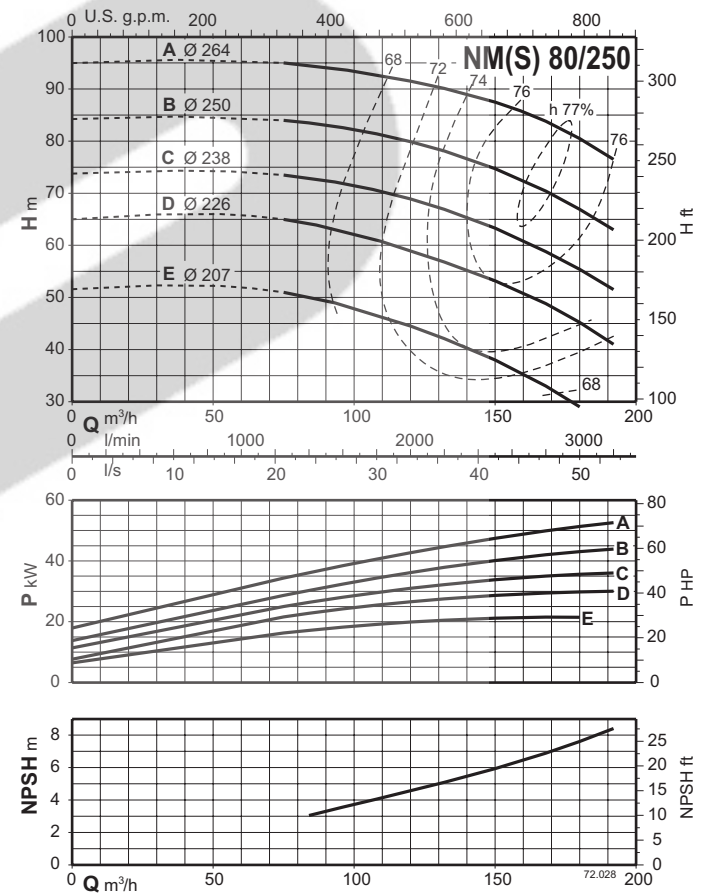
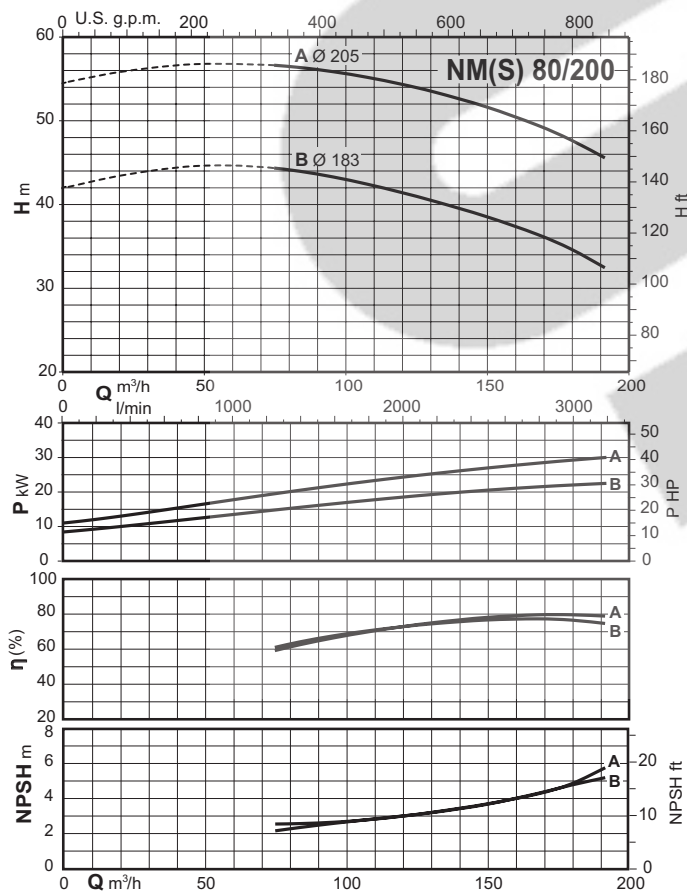
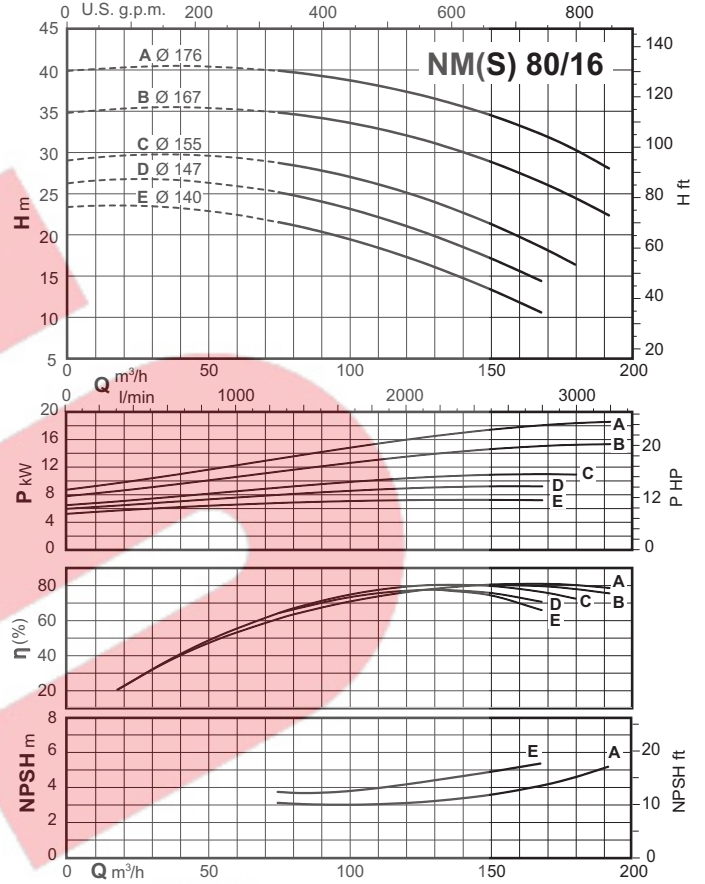
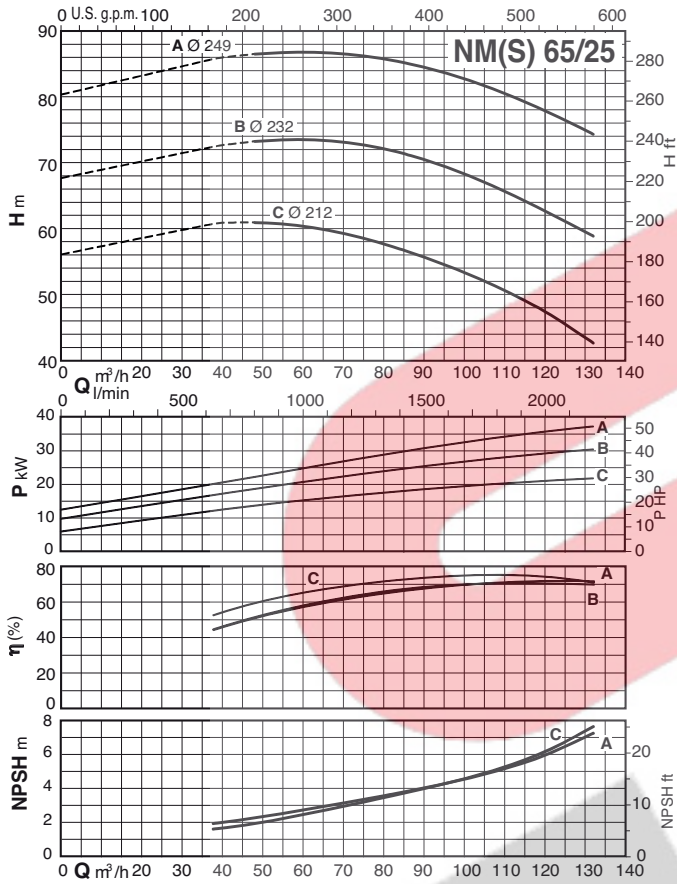

## Characteristic curves $n \approx 2900$ rpm

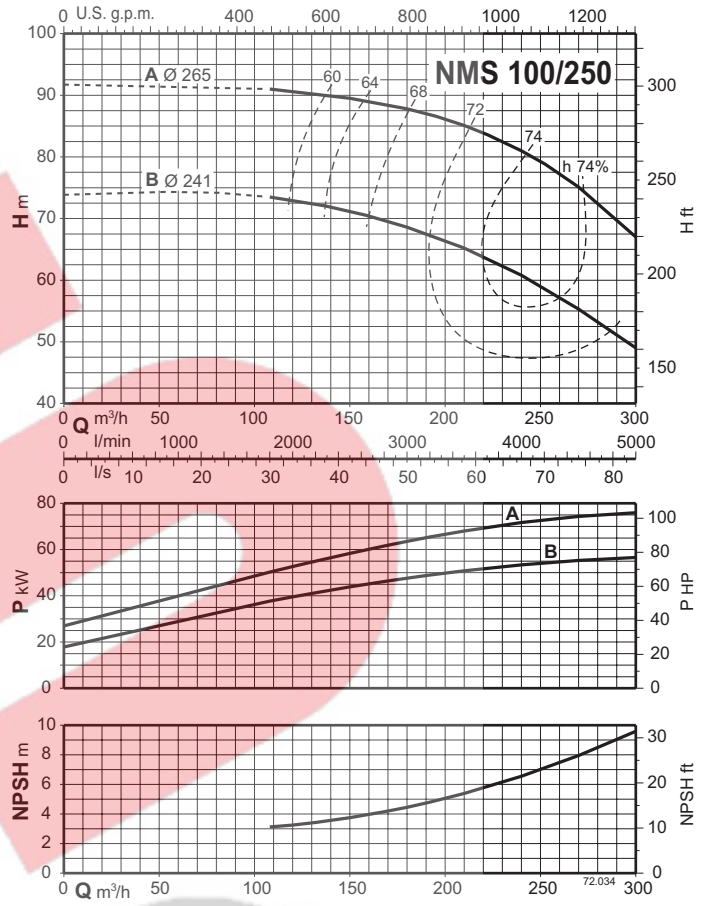
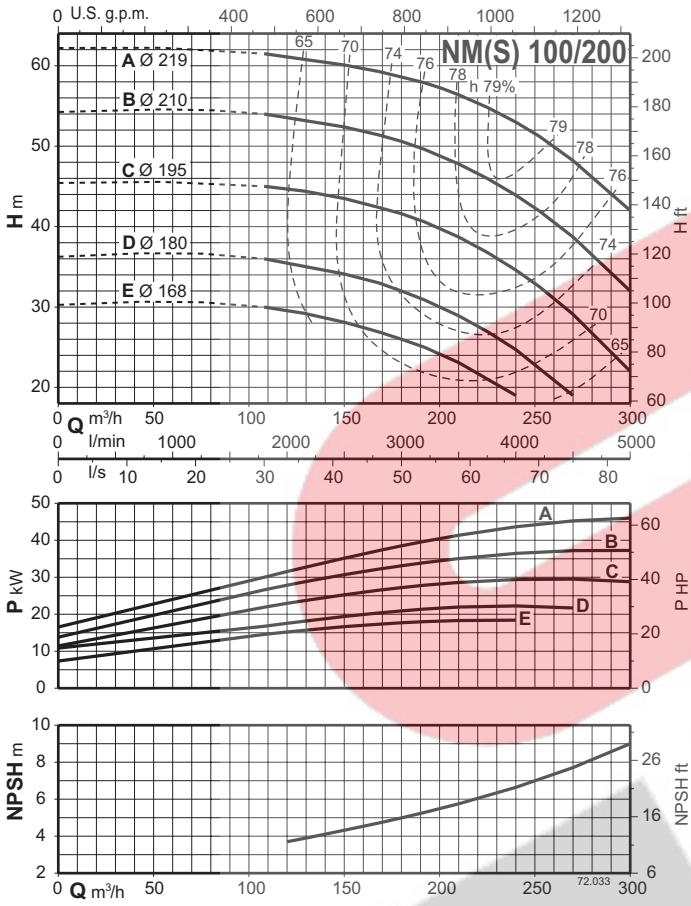

# NM4, NMS4



Characteristic curves  $n \approx 1450$  rpm

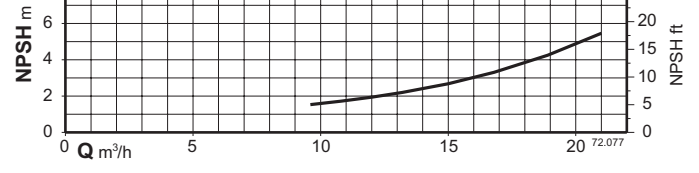
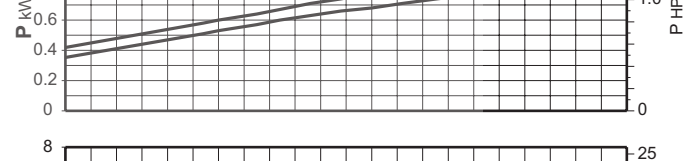
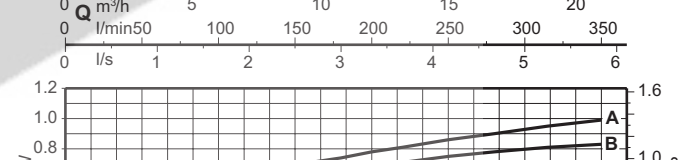
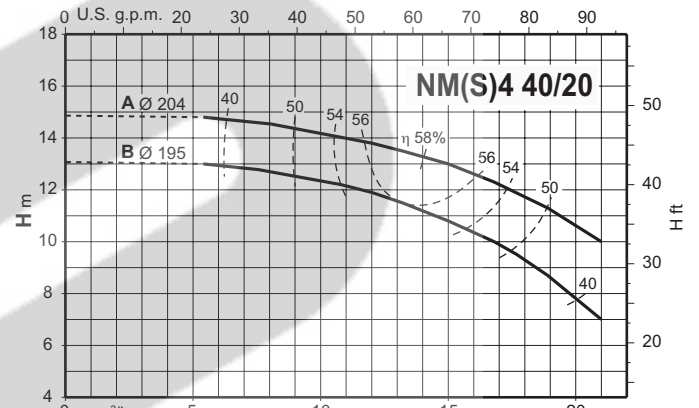
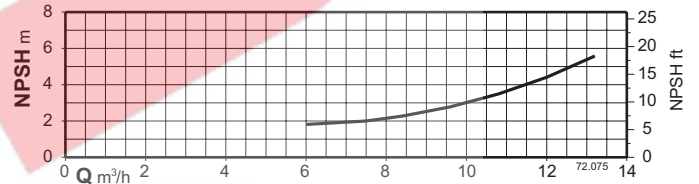
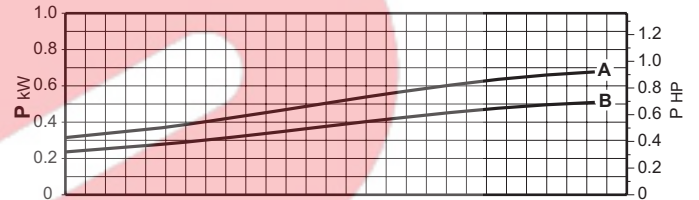
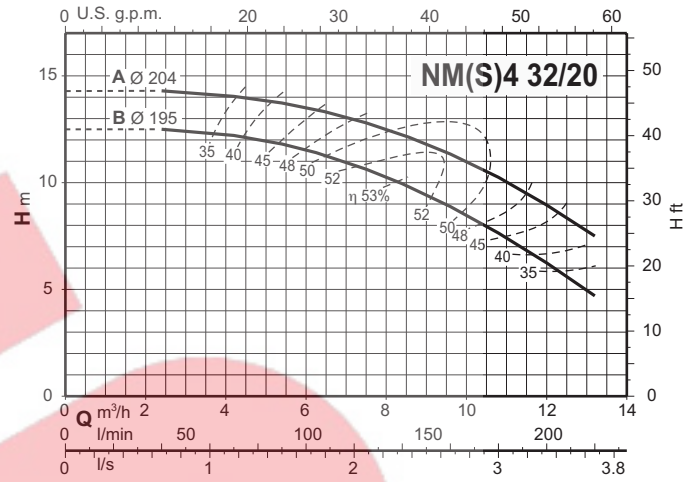
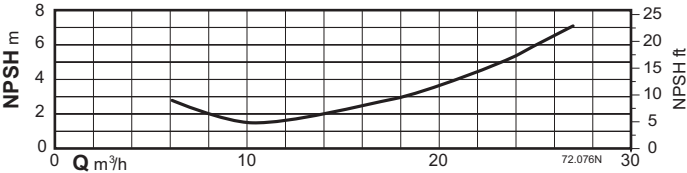
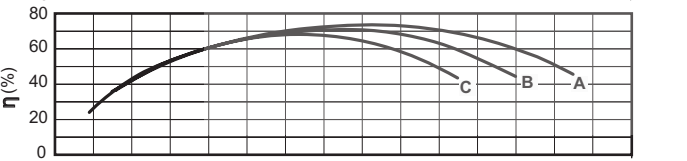
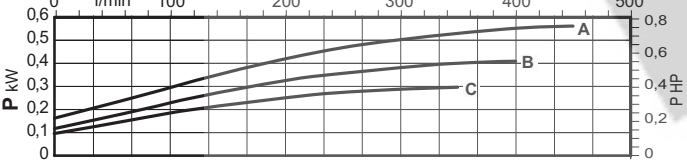
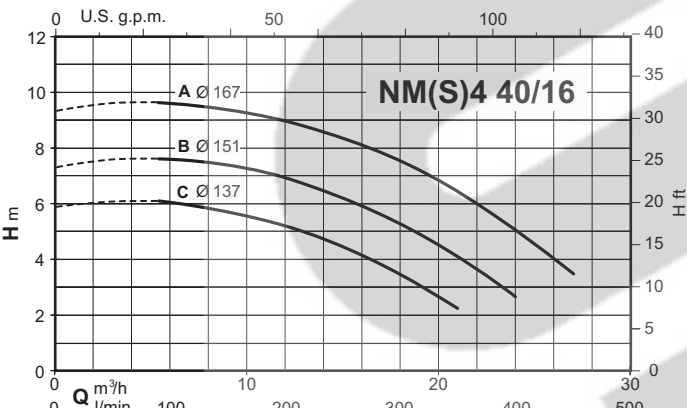
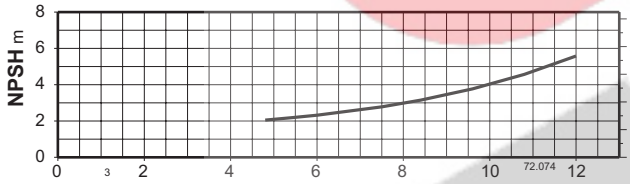
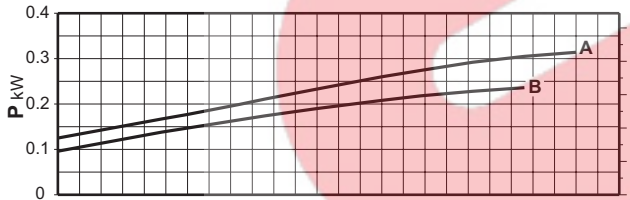
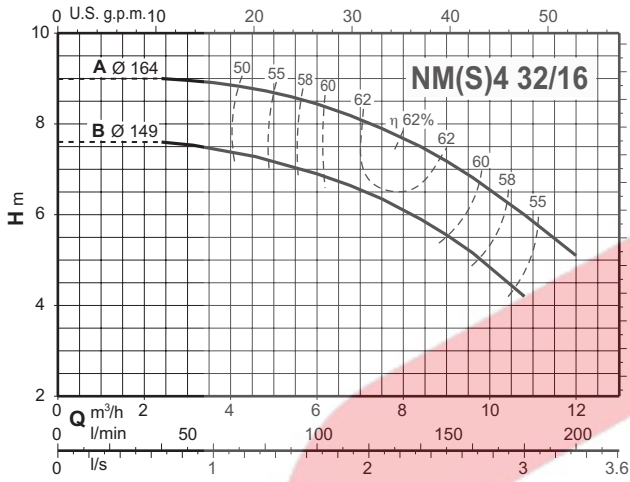

# NM4, NMS4



Characteristic curves  $n \approx 1450$  rpm

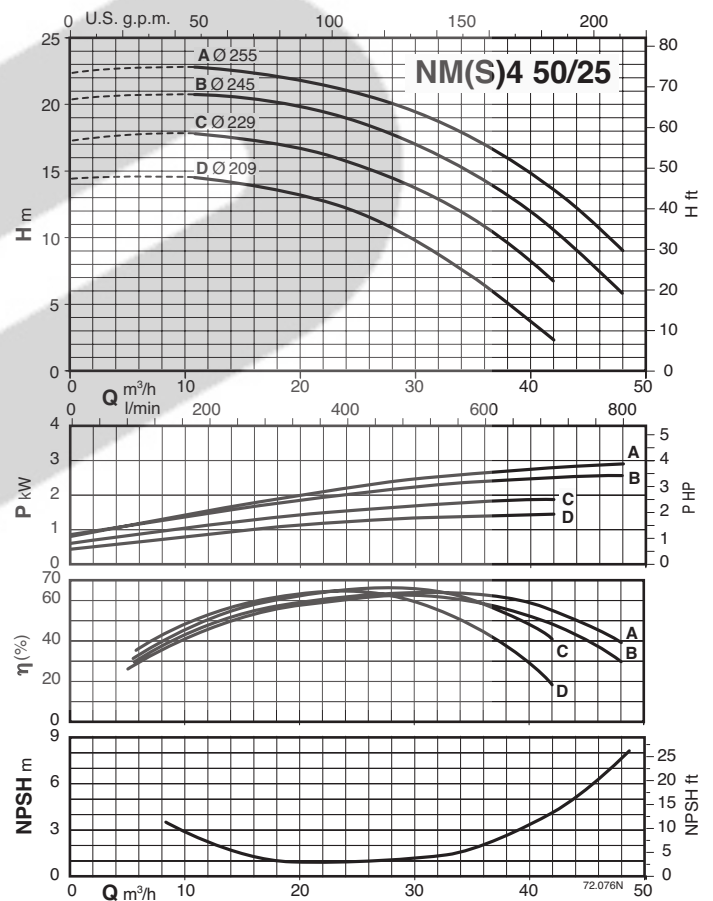
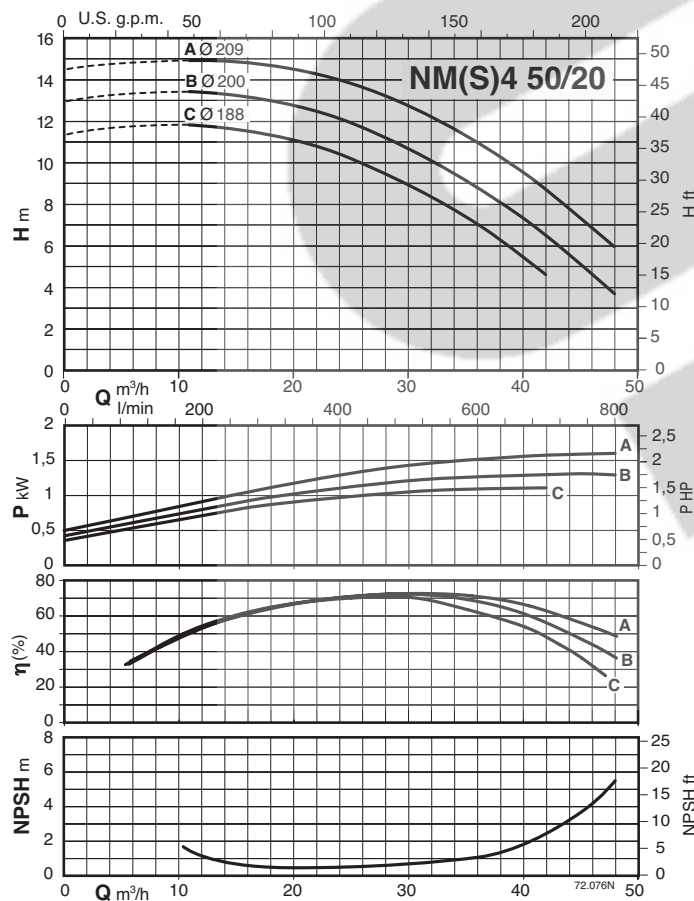
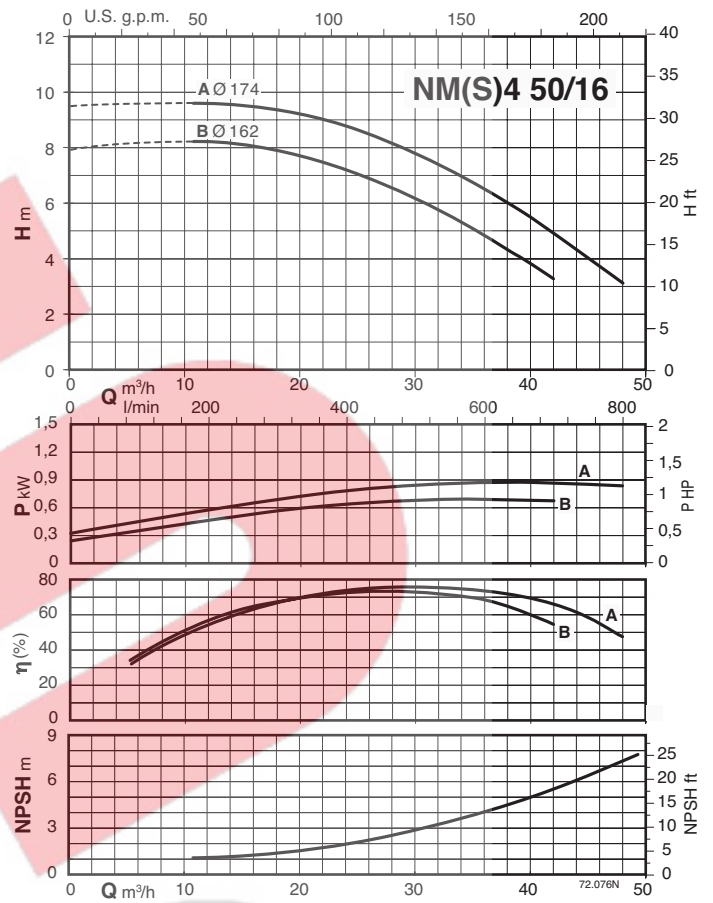
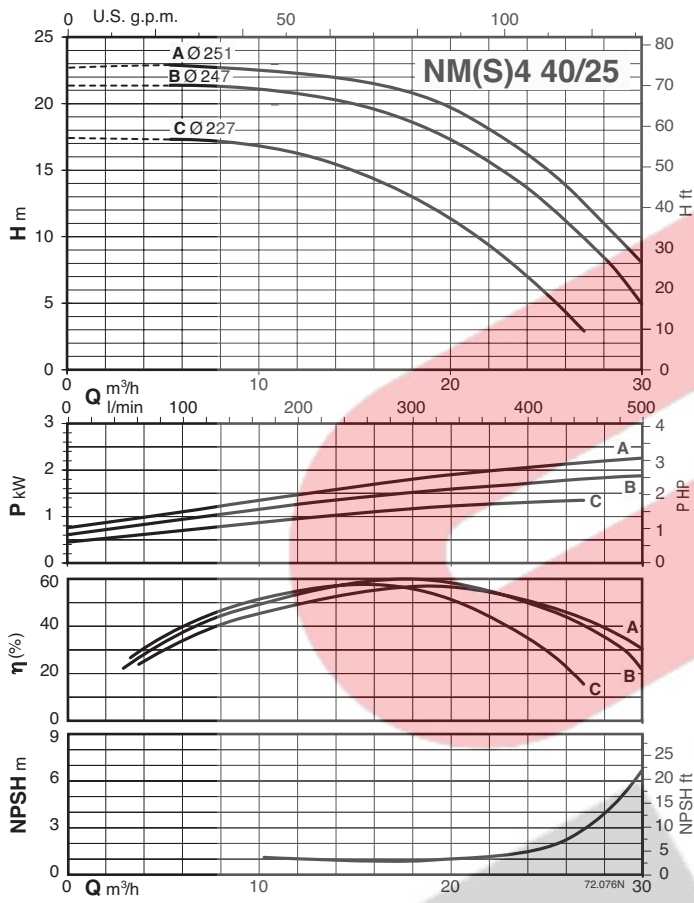

# NM4, NMS4



Characteristic curves  $n \approx 1450$  rpm

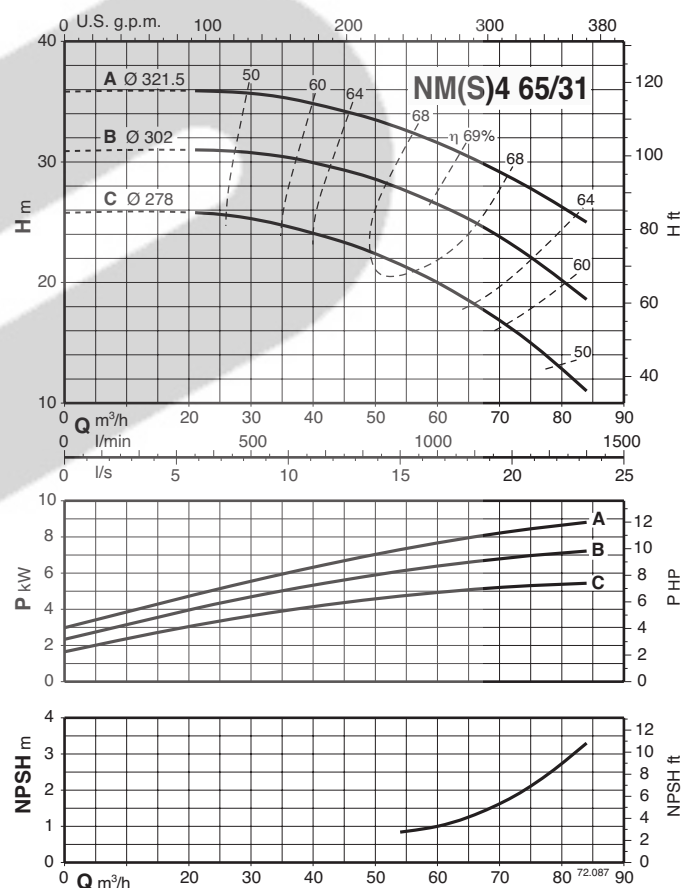
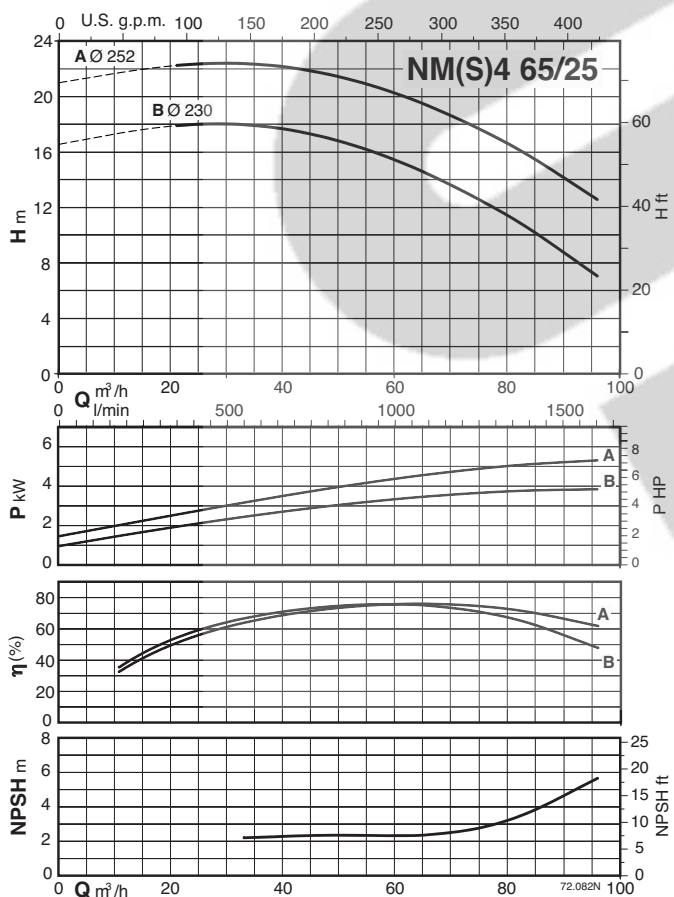
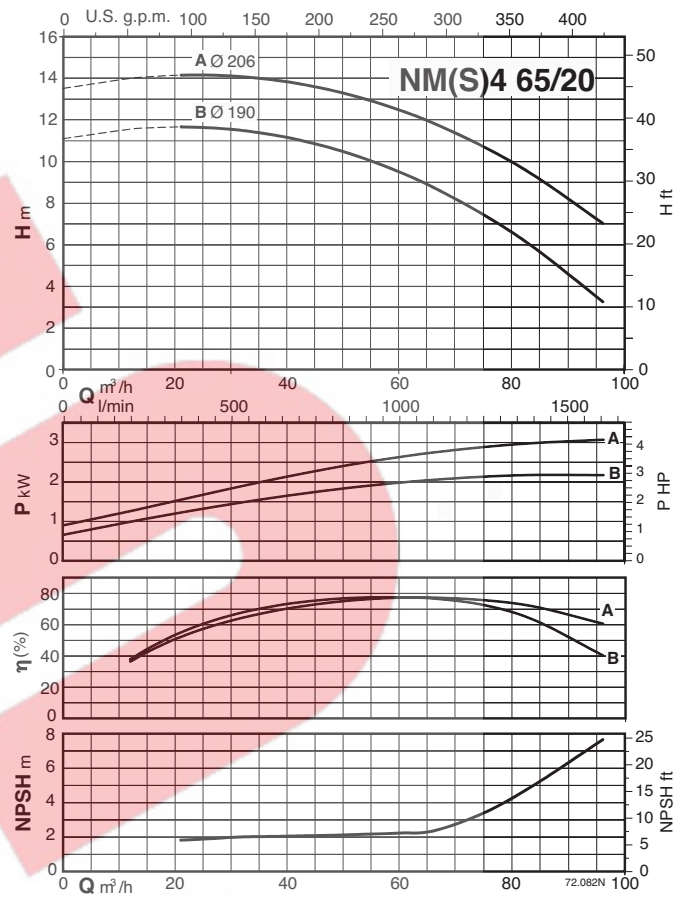
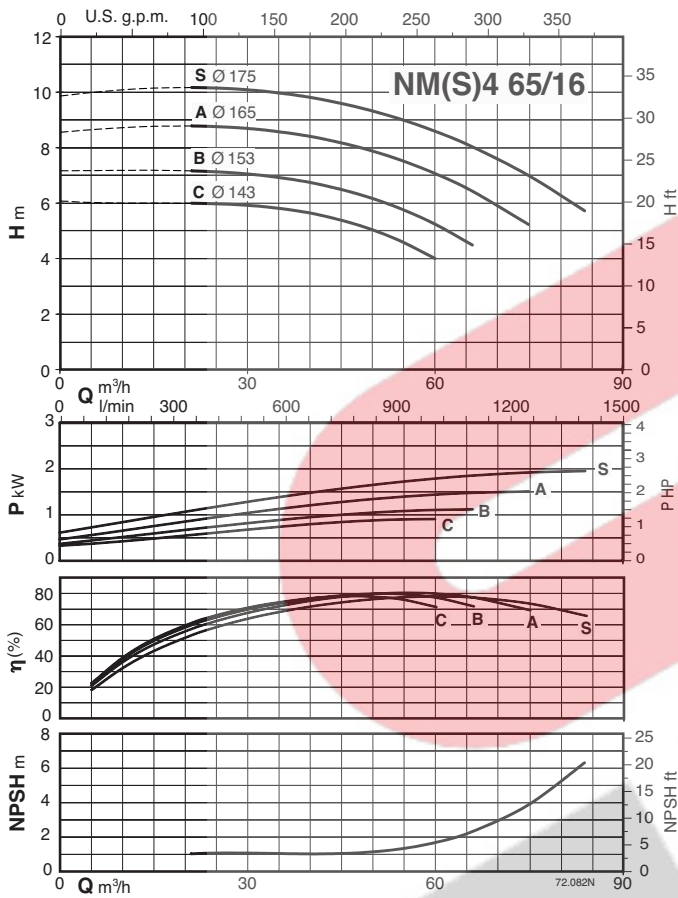

# NM4, NMS4



## Characteristic curves $n \approx 1450$ rpm

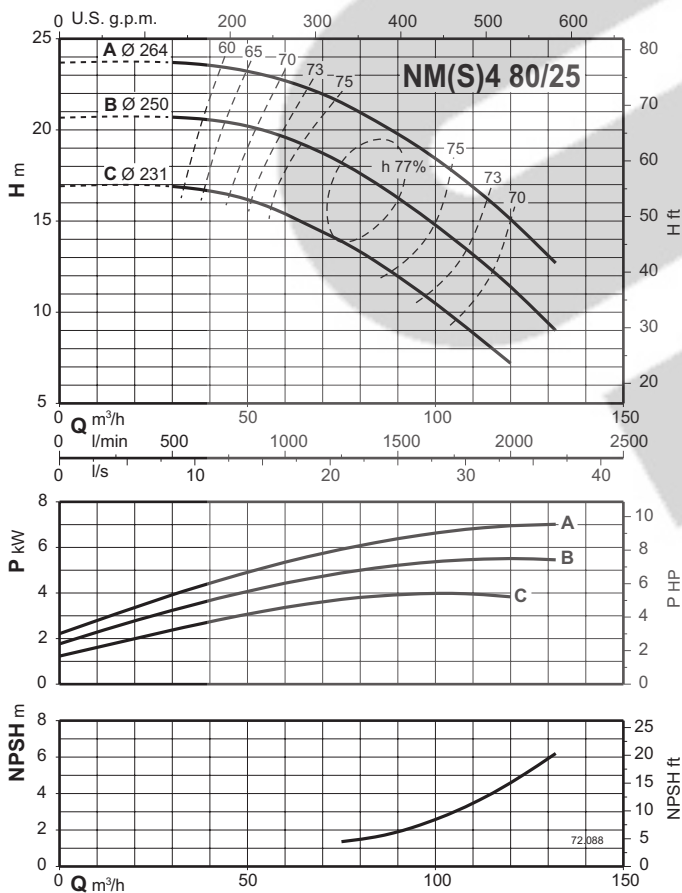
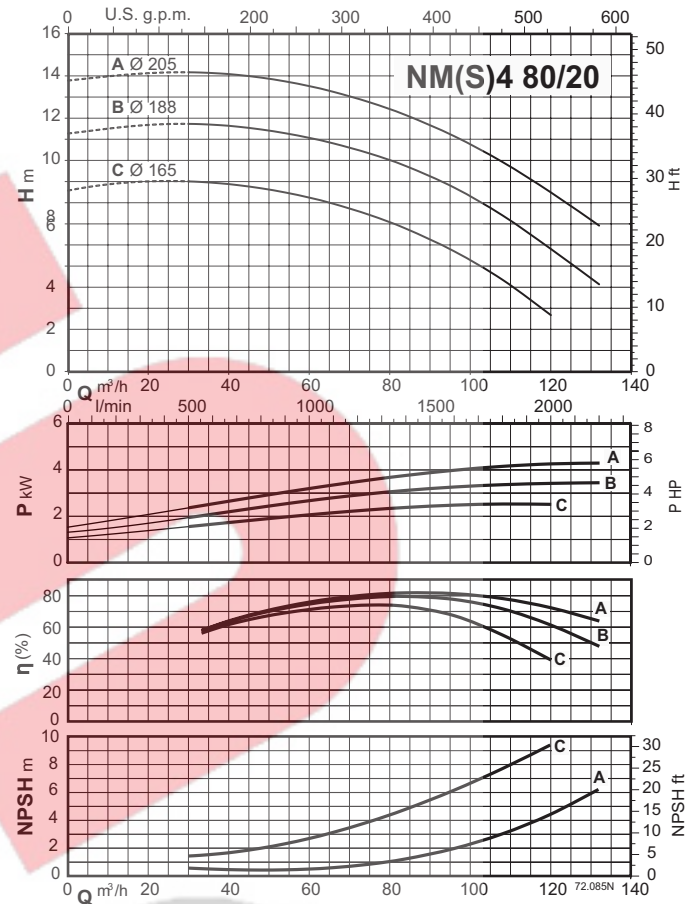
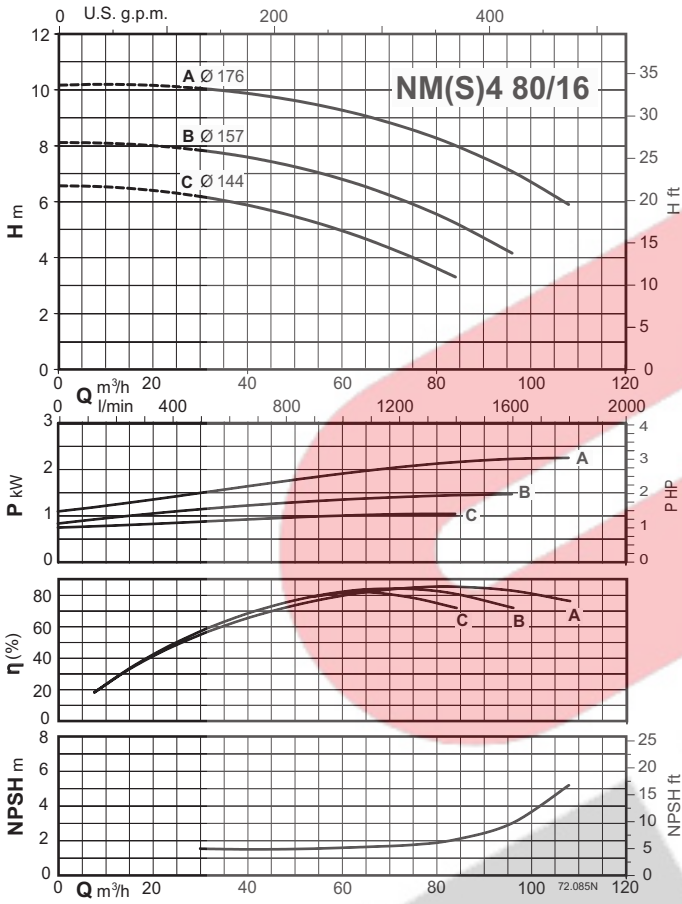

# NM4, NMS4



## Characteristic curves $n \approx 1450$ rpm

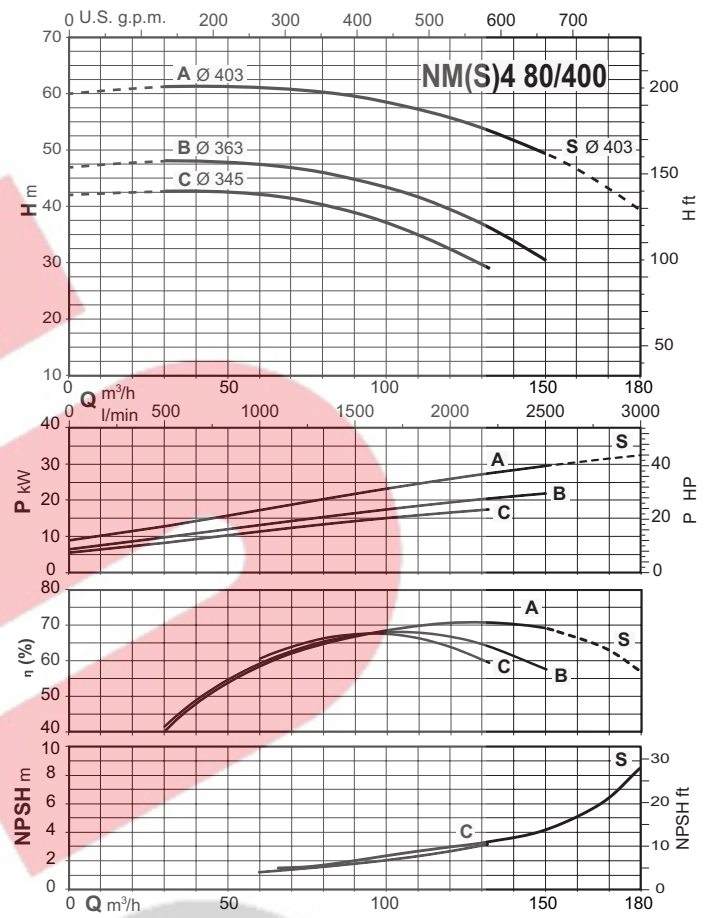
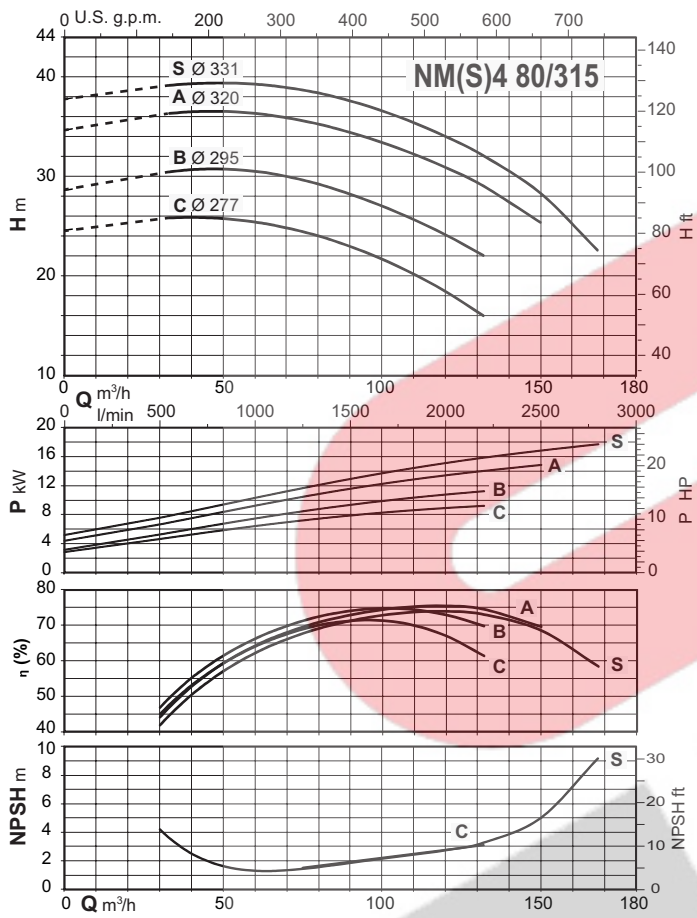

# NM4, NMS4



## Characteristic curves $n \approx 1450$ rpm

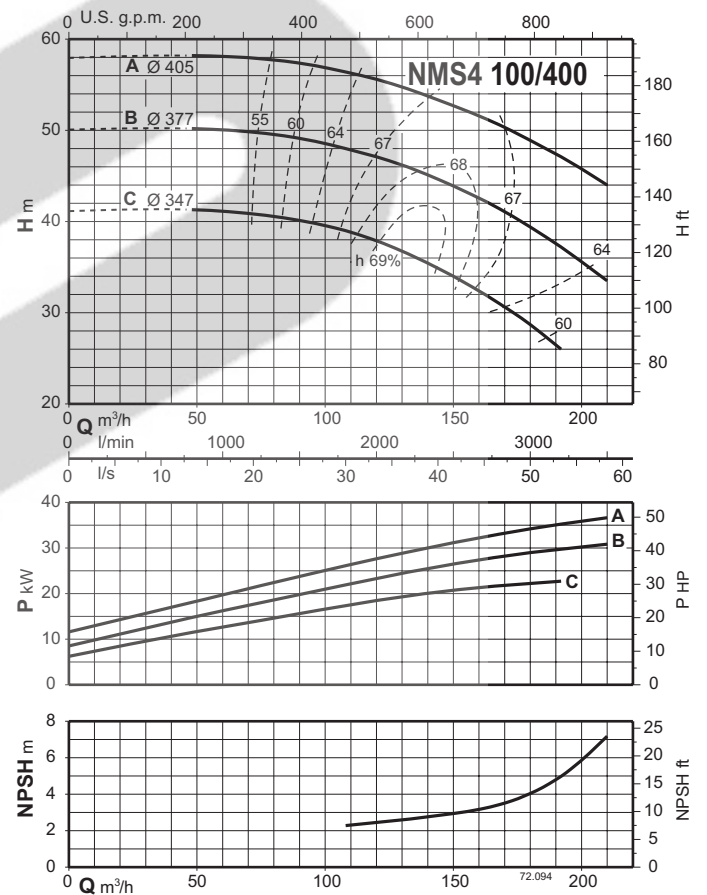
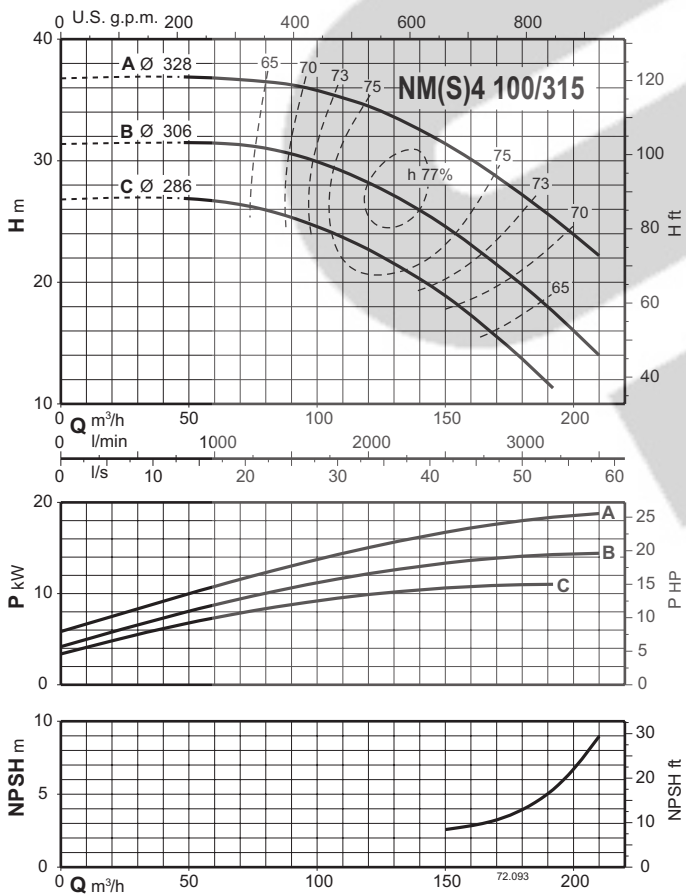
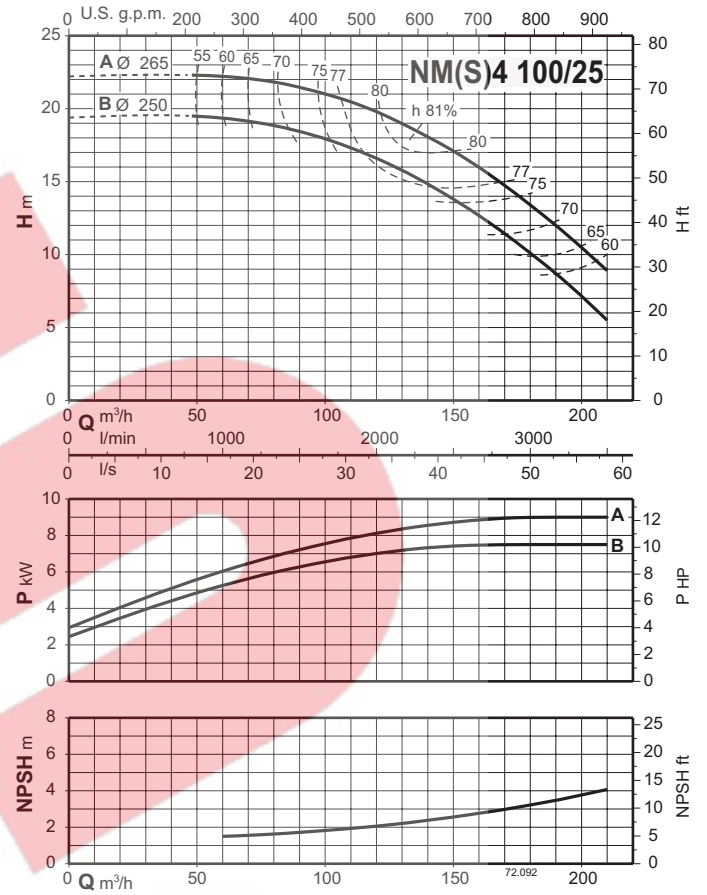
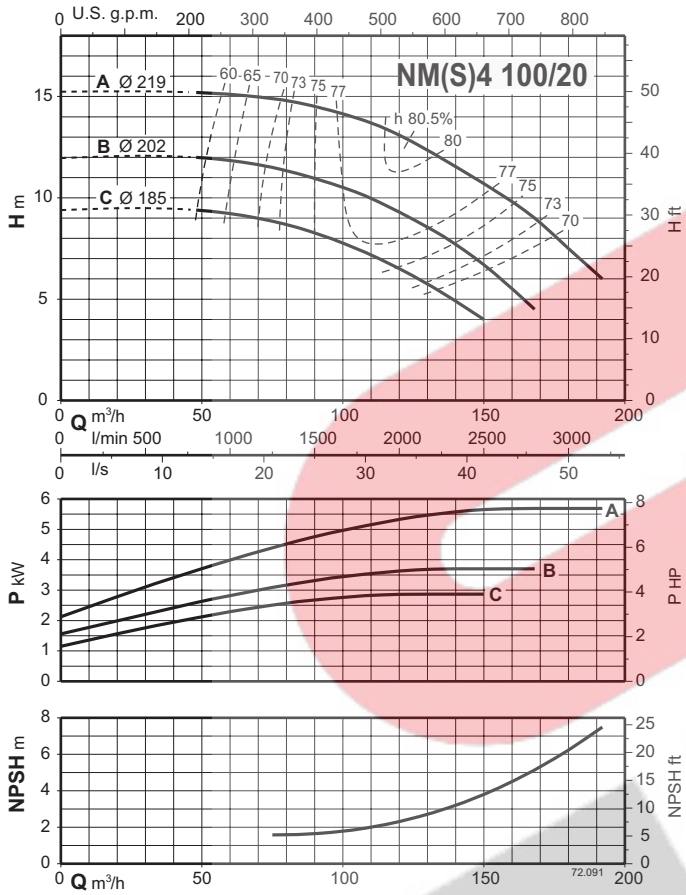

# NM4, NMS4



## Characteristic curves $n \approx 1450$ rpm

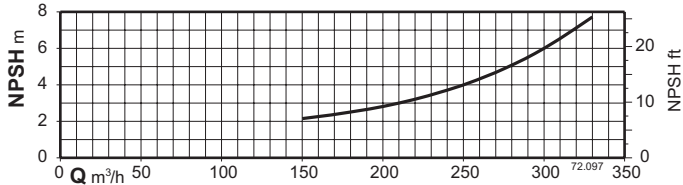
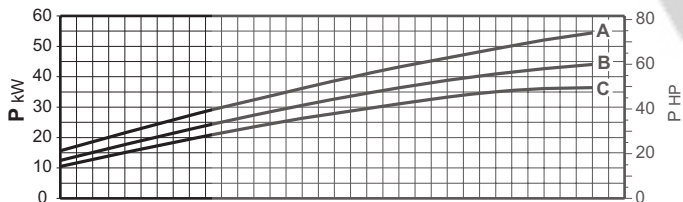
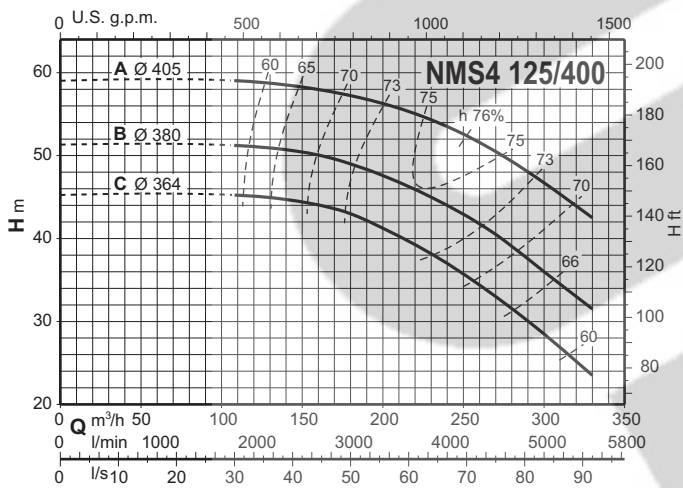
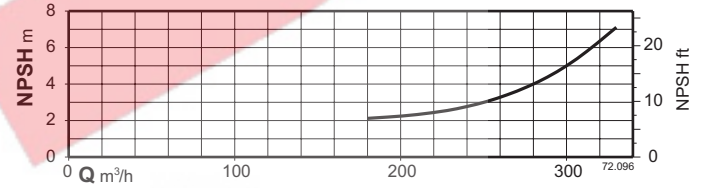
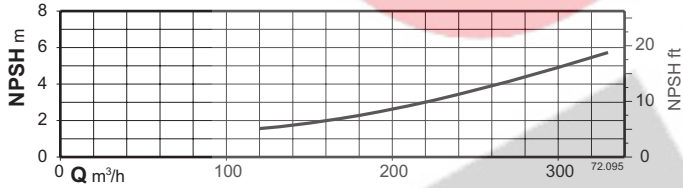
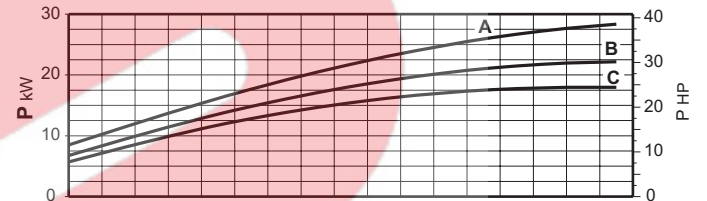
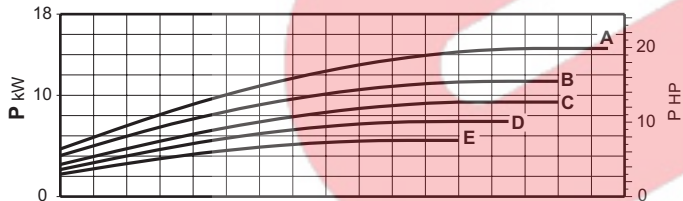
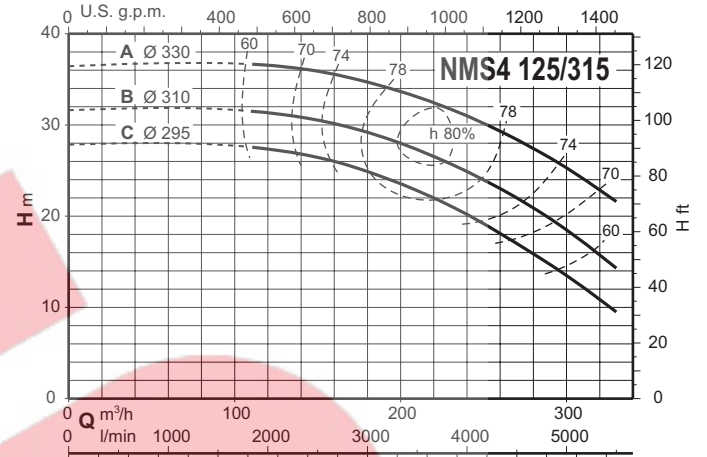
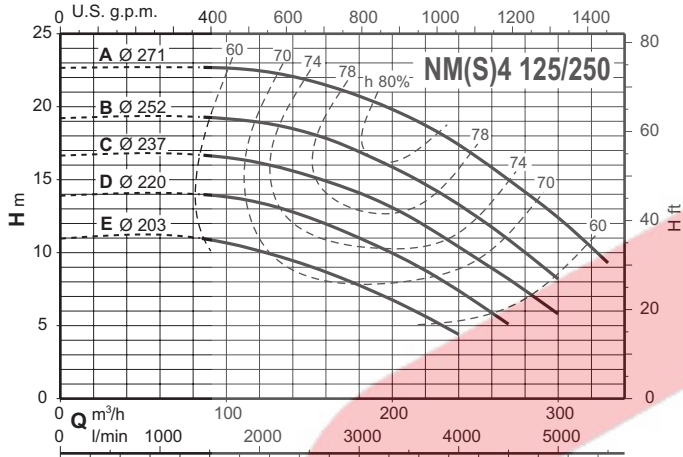

# NM4, NMS4



Characteristic curves  $n \approx 1450$  rpm

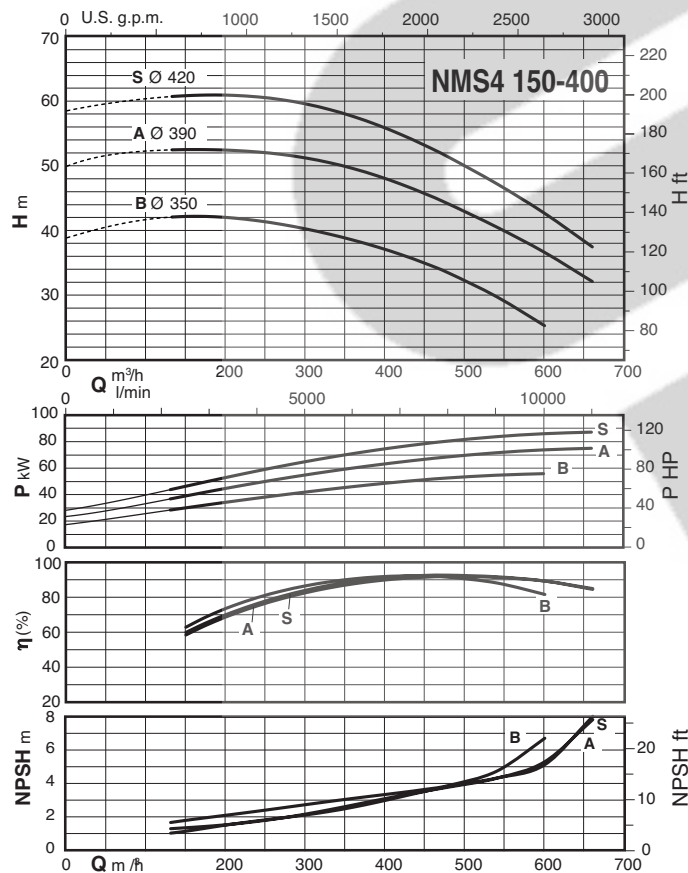
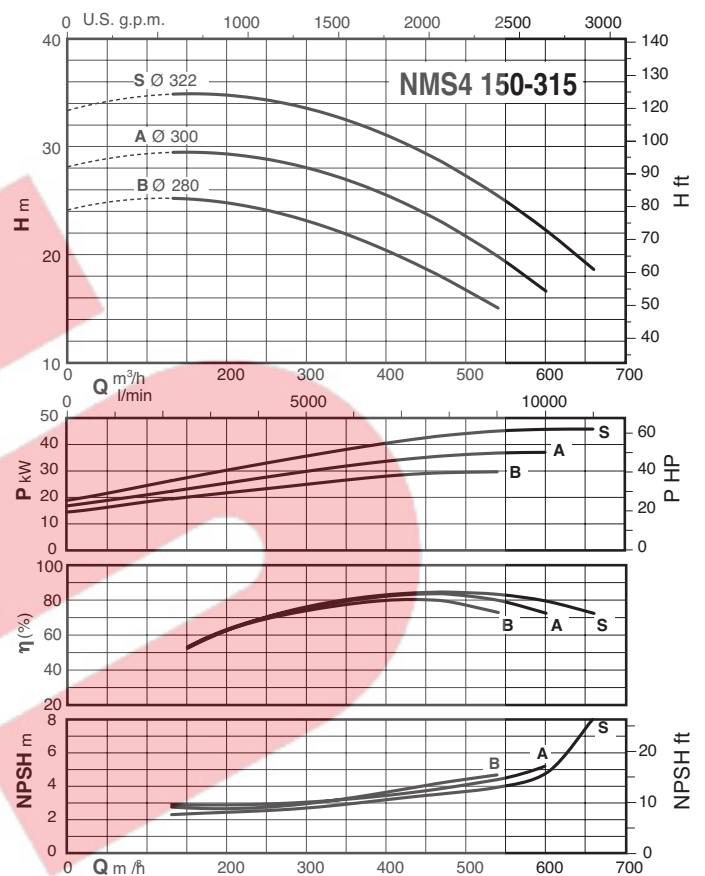
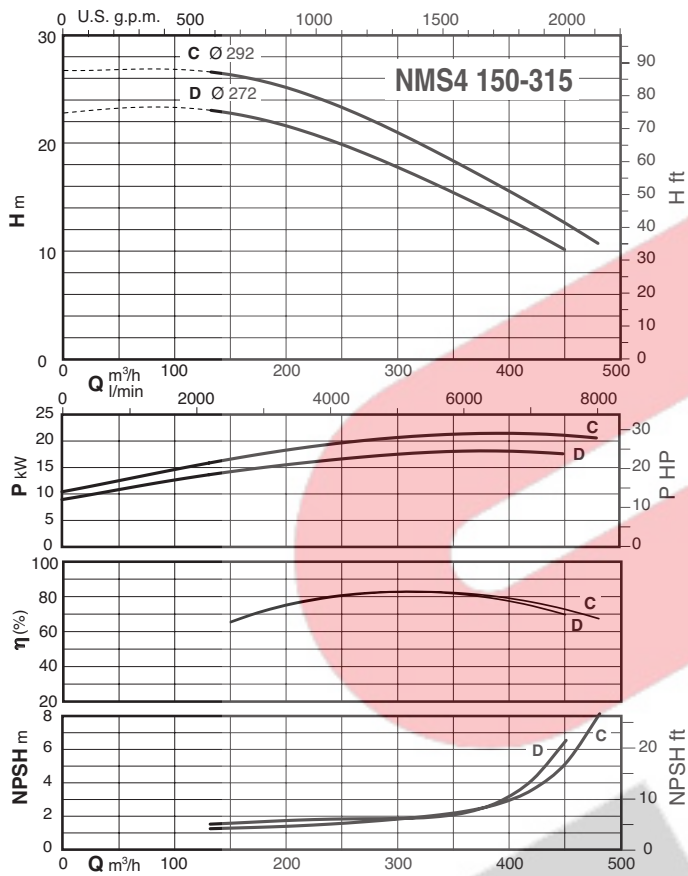

## Dimensions and weights

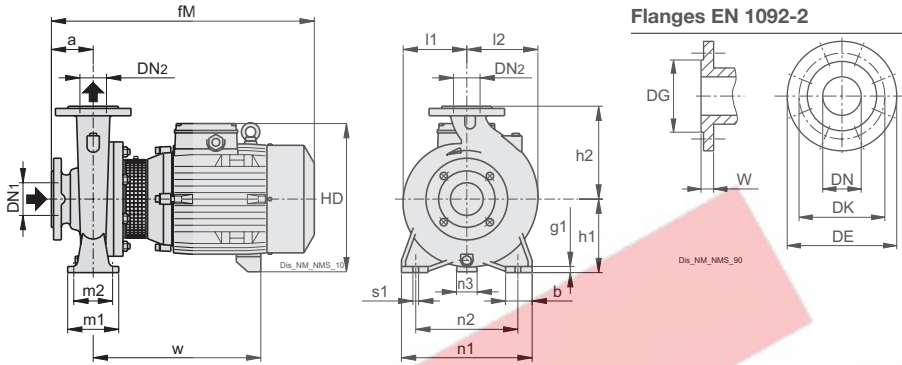

PN 10-16

DN	DG	DK	DE	Holes		W
				N°	ø	
32	76	100	140	4	19	18
40	84	110	150	4	19	18
50	99	125	165	4	19	20
65	118	145	185	4	19	20
80	132	160	200	8	19	22
100	156	180	220	8	19	24
125	184	210	250	8	19	24

## Three-phase

TYPE	DN1	DN2	mm																kg
			a	b	fM	g1	h1	h2	HD	l1	l2	m1	m2	n1	n2	n3	s1	w	Weight
NM 32/12F	50	32	80	50	408	12	112	140	242	93	98	100	70	190	140	31	14	248	23.5
NM 32/12D	50	32	80	50	408	12	112	140	242	93	98	100	70	190	140	31	14	248	23.5
NM 32/12A/A	50	32	80	50	408	12	112	140	242	93	98	100	70	190	140	31	14	248	26.2
NM 32/12S/A	50	32	80	50	408	12	112	140	242	93	98	100	70	190	140	31	14	248	27.2
NM 32/16B/A	50	32	80	50	413	12	132	160	262	119	119	100	70	240	190	35	14	255	33.2
NM 32/16A/B	50	32	80	50	453	12	132	160	262	119	119	100	70	240	190	35	14	295	36.7
<b>NM 32/20D/B</b>	<b>50</b>	<b>32</b>	<b>80</b>	<b>50</b>	<b>453</b>	<b>12</b>	<b>160</b>	<b>180</b>	<b>290</b>	<b>140</b>	<b>140</b>	<b>100</b>	<b>70</b>	<b>240</b>	<b>190</b>	<b>40</b>	<b>14</b>	<b>297</b>	<b>41</b>
NM 32/20C/A	50	32	80	50	479	12	160	180	300	140	140	100	70	240	190	37	14	297	48.8
NM 32/20A/B	50	32	80	50	479	12	160	180	300	140	140	100	70	240	190	37	14	297	51.2
NM 32L/20C	50	32	80	50	479	12	160	180	300	142	142	100	70	240	190	37	14	297	50.6
NM 32L/20B	50	32	80	50	539	12	160	180	327	142	142	100	70	240	190	34	14	335	63.6
NM 32L/20A	50	32	80	50	539	12	160	180	327	142	142	100	70	240	190	34	14	335	68.3
NM 32L/16C	50	32	80	50	453	10	132	160	262	121	121	100	70	240	190	35	14	295	35.2
NM 32L/16B	50	32	80	50	479	10	132	160	272	121	121	100	70	240	190	32	14	294	41.9
NM 32L/16A	50	32	80	50	479	10	132	160	272	121	121	100	70	240	190	32	14	294	45.4
NM 40/12F/B	65	40	80	50	413	12	112	140	242	100	112	100	70	210	160	31	14	253	27.6
NM 40/12C/B	65	40	80	50	413	12	112	140	242	100	112	100	70	210	160	31	14	253	29.4
NM 40/12A/C	65	40	80	50	453	12	112	140	242	100	112	100	70	210	160	31	14	293	32.2
NM 40/16C/C	65	40	80	50	453	10	132	160	262	120	122	100	70	240	190	35	14	295	36.5
NM 40/16B/B	65	40	80	50	479	10	132	160	272	120	122	100	70	240	190	32	14	294	43.3
NM 40/16A/C	65	40	80	50	479	10	132	160	272	120	122	100	70	240	190	32	14	294	46.7
NM 40/20D/B	65	40	100	50	499	12	160	180	300	141	141	100	70	265	212	37	14	297	53
NM 40/20C/B	65	40	100	50	499	12	160	180	300	141	141	100	70	265	212	37	14	297	53.4
NM 40/20B/A	65	40	100	50	559	12	160	180	327	141	141	100	70	265	212	34	14	335	66
NM 40/20A/R/A	65	40	100	50	559	12	160	180	327	141	141	100	70	265	212	34	14	335	65.7
NM 40/20A/A	65	40	100	50	559	12	160	180	327	141	141	100	70	265	212	34	14	335	70.6
NM 40/25C/C	65	40	100	65	639	15	180	225	370	177	177	125	95	320	250	35	14	397	107.8
NM 40/25B/C	65	40	100	65	639	15	180	225	370	177	177	125	95	320	250	35	14	397	115.3
NM 40/25A/C	65	40	100	65	714	15	180	225	370	177	177	125	95	320	250	35	14	472	135
NM 50/12F/C	65	50	100	50	473	10	132	160	262	122	137	100	70	240	190	35	14	295	37.2
NM 50/12D/B	65	50	100	50	499	10	132	160	272	122	137	100	70	240	190	32	14	294	44.8
NM 50/12A/C	65	50	100	50	499	10	132	160	272	122	137	100	70	240	190	32	14	294	48.2
NM 50/12S/C	65	50	100	50	499	10	132	160	272	122	137	100	70	240	190	32	14	294	48.3
NM 50/16B/B	65	50	100	50	559	12	160	180	327	125	140	100	70	265	212	34	14	335	64.2
NM 50/16A/B	65	50	100	50	559	12	160	180	327	125	140	100	70	265	212	34	14	335	68.8
NM 50/20B/C	65	50	100	50	639	14	160	200	350	142	152	100	70	265	212	31	14	395	99.6
NM 50/20A/C	65	50	100	50	639	14	160	200	350	142	152	100	70	265	212	31	14	395	106.9
NM 50/20S/C	65	50	100	50	714	14	160	200	350	142	152	100	70	265	212	31	14	470	131
NM 50/25C/C	65	50	100	65	644	15	180	225	370	177	177	125	95	320	250	35	14	402	120
NM 50/25B/C	65	50	100	65	719	15	180	225	370	177	177	125	95	320	250	35	14	477	145.3
NM 65/12E/C	80	65	100	65	504	12	160	180	300	130	154	125	95	280	212	37	14	302	52
NM 65/12C/B	80	65	100	65	564	12	160	180	327	130	154	125	95	280	212	34	14	340	65.5
NM 65/12A/B	80	65	100	65	564	12	160	180	327	130	154	125	95	280	212	34	14	340	71.1
NM 65/16D/B	80	65	100	65	559	12	160	200	327	140	161	125	95	280	212	34	14	335	70.5
NM 65/16C/C	80	65	100	65	639	12	160	200	350	140	161	125	95	280	212	31	14	395	93
NM 65/16B/C	80	65	100	65	639	12	160	200	350	140	161	125	95	280	212	31	14	395	101.5
NM 65/16A/R	80	65	100	65	714	12	160	200	350	140	161	125	95	280	212	31	14	470	120.2
NM 65/16A/C	80	65	100	65	714	12	160	200	350	140	161	125	95	280	212	31	14	470	124.5
NM 65/20C/C	80	65	100	65	714	12	180	225	370	159	179	125	95	320	250	35	14	472	130.9
NM 80/16E/B	100	80	125	65	584	12	180	225	347	152	181	125	95	320	250	37	14	337	78.5
NM 80/16D/C	100	80	125	65	669	12	180	225	370	152	181	125	95	320	250	35	14	402	101
NM 80/16C/C	100	80	125	65	669	12	180	225	370	152	181	125	95	320	250	35	14	402	109.8
NM 80/16B/C	100	80	125	65	744	12	180	225	370	152	181	125	95	320	250	35	14	477	132.5

## Dimensions and weights

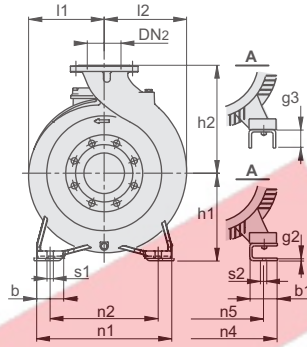
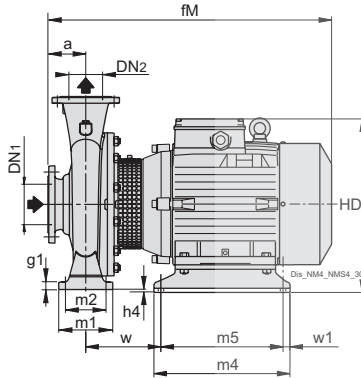

Flanges EN 1092-2

PN 10-16

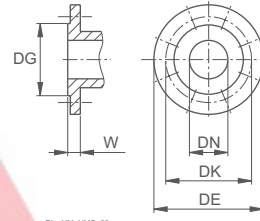

mm						
DN	DG	DK	DE	Holes		W
				N°	ø	
32	76	100	140	4	19	18
40	84	110	150	4	19	18
50	99	125	165	4	19	20
65	118	145	185	4	19	20
80	132	160	200	8	19	22
100	156	180	220	8	19	24
125	184	210	250	8	19	24

## Three-phase

TYPE			mm																								kg
	DN1	DN2	a	b	b1	fM	g1	g3	h1	h2	h4	HD	l1	l2	m1	m2	m4	m5	n1	n2	n4	n5	s1	s2	w	w1	Weight
NM 50/25A/D	65	50	100	65	80	765	15	20	180	225	-	388	177	177	125	95	394	354	320	250	334	254	14	15	185	20	168.2
NM 50/25S	65	50	100	65	80	765	15	20	180	225	-	388	177	177	125	95	394	354	320	250	334	254	14	15	185	20	175.7
NM 65/20B/D	80	65	100	65	80	765	12	20	180	225	-	388	159	179	125	95	394	354	320	250	334	254	14	15	185	20	163
NM 65/20A/A	80	65	100	65	80	765	12	20	180	225	-	388	159	179	125	95	394	354	320	250	334	254	14	15	185	20	168.9
NM 65/25C/A	80	65	100	80	90	765	15	42	200	250	2	408	178	195	160	120	400	360	360	280	344	254	18	14	182	20	187.4
NM 80/16A/D	100	80	125	65	80	790	12	20	180	225	-	388	152	181	125	95	394	354	320	250	334	254	14	15	185	20	157.9
NM 80/20B/A	100	80	125	65	90	790	15	42	180	250	22	388	170	194	125	95	400	360	345	280	344	254	14	14	182	20	178
NM 80/25E	100	80	125	80	90	790	20	42	200	280	2	408	191	211	160	120	400	360	400	315	344	254	18	14	182	20	190.2
NM 100/20E/A	125	100	125	80	60	790	15	40	200	280	-	408	179	211	160	120	394	354	360	280	314	254	18	15	185	20	174.8
NM 100/20D	125	100	125	80	60	790	15	40	200	280	-	408	179	211	160	120	394	354	360	280	314	254	18	15	185	20	182.6

## Dimensions and weights with IE3 motor

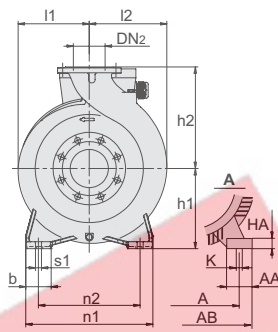
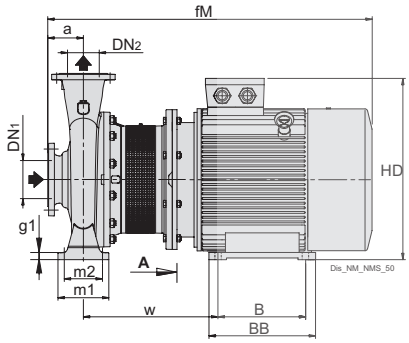

Flanges EN 1092-2

PN 10-16

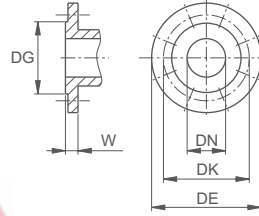

mm						
DN	DG	DK	DE	Holes		W
				N°	ø	
32	76	100	140	4	19	18
40	84	110	150	4	19	18
50	99	125	165	4	19	20
65	118	145	185	4	19	20
80	132	160	200	8	19	22
100	156	180	220	8	19	24
125	184	210	250	8	19	24

TYPE	DN		mm																				kg		
	DN1	DN2	a	A	AA	AB	B	BB	fM	g1	h1	h2	HA	HD	K	l1	l2	m1	m2	n1	n2	s1		w	Weight
NMS 65/200A	80	65	100	279	70	350	65	241	312	955	12	180	225	22	450	15	159	179	125	95	320	250	14	394	-
NMS 65/250B/B	80	65	100	318	70	390	80	305	370	1006	15	200	250	25	500	19	178	195	160	120	360	280	18	406	-
NMS 65/250A/B	80	65	100	318	70	390	80	305	370	1006	15	200	250	25	500	19	178	195	160	120	360	280	18	406	-
NMS 80/200B/B	100	80	125	279	70	350	65	241	312	980	15	180	250	22	450	15	170	194	125	95	345	280	14	394	-
NMS 80/250D/A	100	80	125	318	70	390	80	305	370	1031	20	200	280	25	500	19	191	211	160	120	400	315	18	406	-
NMS 80/250C/A	100	80	125	318	70	390	80	305	370	1031	20	200	280	25	500	19	191	211	160	120	400	315	18	406	-
NMS 100/200C/A	125	100	125	318	70	390	80	305	370	1031	15	200	280	25	500	19	179	211	160	120	360	280	18	406	308
NMS 100/200B/A	125	100	125	318	70	390	80	305	370	1031	15	200	280	25	500	19	179	211	160	120	360	280	18	406	-

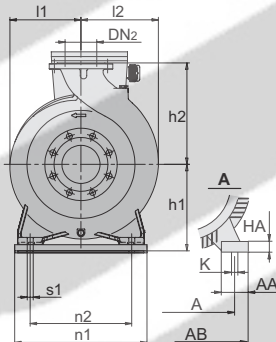
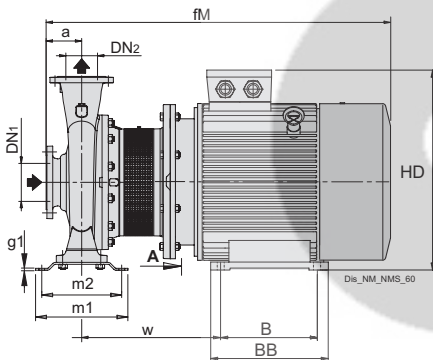

Flanges EN 1092-2

PN 10-16

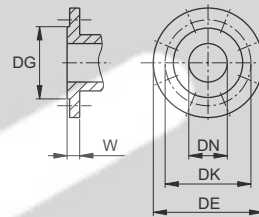

mm						
DN	DG	DK	DE	Holes		W
				N°	ø	
32	76	100	140	4	19	18
40	84	110	150	4	19	18
50	99	125	165	4	19	20
65	118	145	185	4	19	20
80	132	160	200	8	19	22
100	156	180	220	8	19	24
125	184	210	250	8	19	24

TYPE	DN		mm																				kg	
	DN1	DN2	a	A	AA	AB	B	BB	fM	g1	h1	h2	HA	HD	K	l1	l2	m1	m2	n1	n2	s1		w
NMS 80/200A/B	100	80	125	318	70	390	305	370	1031	6	200	250	25	500	19	170	194	227	191	350	280	14	406	-
NMS 80/250B/A	100	80	125	356	75	431	311	395	1089	6	225	280	28	555	19	191	211	298	258	410	315	18	445	-
NMS 100/200A/A	125	100	125	356	75	431	311	395	1089	6	225	280	28	555	19	179	211	298	258	410	315	18	445	-
NMS 100/250A/A	125	100	140	457	85	545	368	485	1276	6	280	280	38	670	24	205	233	260	220	410	315	18	516	-

## Dimensions and weights with IE3 motor

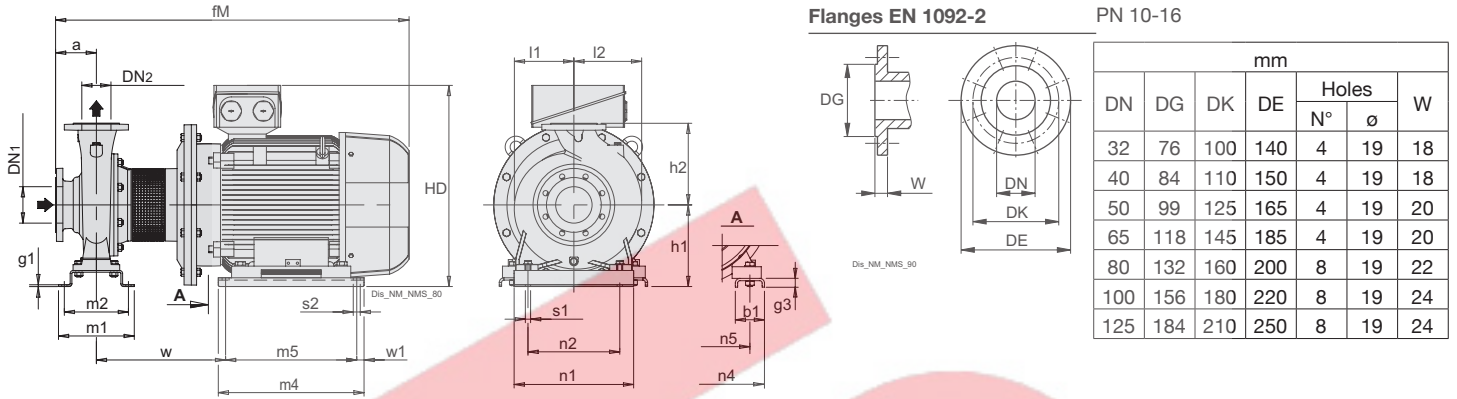

TYPE	mm																							
	DN1	DN2	a	b1	fM	g1	g3	h1	h2	HD	l1	l2	m1	m2	m4	m5	n1	n2	n4	n5	s1	s2	w	w1
NMS 80/250A/A	100	80	125	100	1321	6	30	280	280	642	191	211	260	220	570	520	410	315	506	406	18	24	408	25
NMS 100/250B/A	125	100	140	100	1336	6	30	280	280	642	205	233	260	220	570	520	410	315	506	406	18	24	408	25

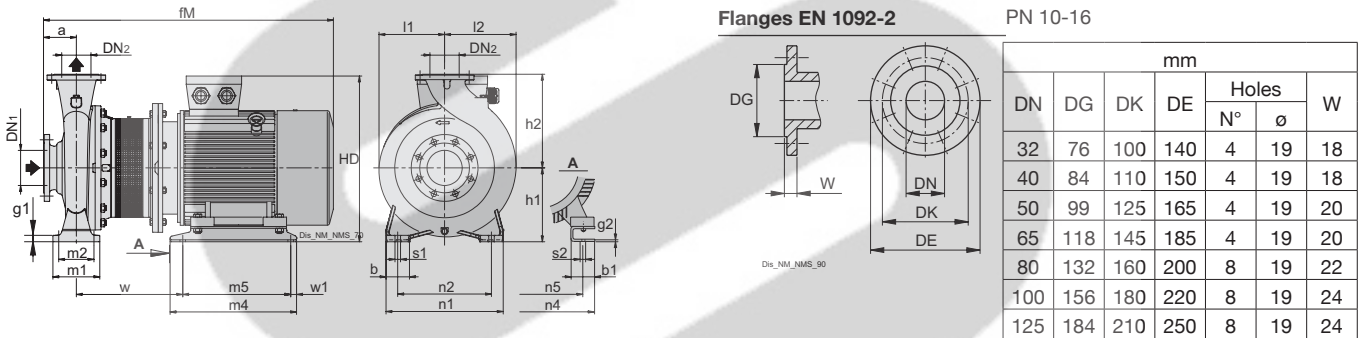

TYPE	mm																								
	DN1	DN2	a	b	b1	fM	g1	g3	h1	h2	HD	l1	l2	m1	m2	m4	m5	n1	n2	n4	n5	s1	s2	w	w1
NMS 65/250C	80	65	100	80	70	955	15	20	200	250	470	178	195	160	120	440	400	360	280	349	279	18	15	333	20
NMS 80/250E	100	80	125	80	70	980	20	20	200	280	470	191	211	160	120	440	400	400	315	349	279	18	15	333	20
NMS 100/200D/A	125	100	125	80	70	980	15	20	200	280	470	179	211	160	120	440	400	360	280	349	279	18	15	333	20

## Dimensions and weights with IE4 motor

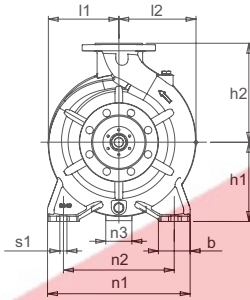
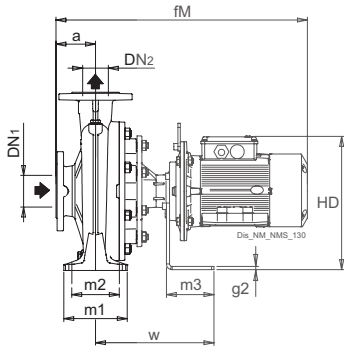

Flanges EN 1092-2

PN 10-16

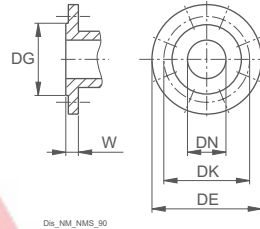

mm						
DN	DG	DK	DE	Holes		W
				N°	ø	
32	76	100	140	4	19	18
40	84	110	150	4	19	18
50	99	125	165	4	19	20
65	118	145	185	4	19	20
80	132	160	200	8	19	22
100	156	180	220	8	19	24
125	184	210	250	8	19	24

TYPE	mm																			
	DN1	DN2	a	b	fM	g1	g2	h1	h2	HD	l1	l2	m1	m2	m3	n1	n2	n3	s1	w
NMS 32/125D	50	32	80	50	536	12	8	112	140	241	93	98	100	70	120	190	140	65	14	274
NMS 32/125D-S	50	32	80	50	536	12	8	112	140	241	93	98	100	70	120	190	140	65	14	274
NMS 32/125A	50	32	80	50	536	12	8	112	140	241	93	98	100	70	120	190	140	65	14	274
NMS 32/125S	50	32	80	50	576	12	8	112	140	241	93	98	100	70	120	190	140	65	14	274
NMS 32/125A-S	50	32	80	50	576	12	8	112	140	241	93	98	100	70	120	190	140	65	14	274
NMS 32/160B	50	32	80	50	576	12	8	132	160	261	119	119	100	70	120	240	190	65	14	274
NMS 32/160B-S	50	32	80	50	576	12	8	132	160	261	119	119	100	70	120	240	190	65	14	274
NMS 32/160A	50	32	80	50	576	12	8	132	160	261	119	119	100	70	120	240	190	65	14	274
NMS 32/160A-S	50	32	80	50	590	12	8	132	160	270	119	119	100	70	120	240	190	65	14	274
NMS 32/200D	50	32	80	50	576	12	8	160	180	289	140	140	100	70	120	240	190	65	14	274
NMS 32/200D-S	50	32	80	50	590	12	8	160	180	298	140	140	100	70	120	240	190	65	14	274
NMS 32/200C	50	32	80	50	590	12	8	160	180	298	140	140	100	70	120	240	190	65	14	274
NMS 32/200A	50	32	80	50	617	12	8	160	180	334	140	140	100	70	120	240	190	65	14	274
NMS 32/200A-S	50	32	80	50	646	12	8	160	180	320	140	140	100	70	250	240	190	130	14	407
NMS 32L/160C	50	32	80	50	576	10	8	132	160	261	121	121	100	70	120	240	190	65	14	274
NMS 32L/160B	50	32	80	50	590	10	8	132	160	270	121	121	100	70	120	240	190	65	14	274
NMS 32L/160A	50	32	80	50	617	10	8	132	160	306	121	121	100	70	120	240	190	65	14	274
NMS 32L/200C	50	32	80	50	617	12	8	160	180	334	142	142	100	70	120	240	190	65	14	274
NMS 32L/200B	50	32	80	50	646	12	8	160	180	320	142	142	100	70	250	240	190	130	14	407
NMS 32L/200A	50	32	80	50	763	12	8	160	180	352	142	142	100	70	250	240	190	130	14	407
NMS 40/125F	65	40	80	50	536	12	8	112	140	241	100	112	100	70	120	210	160	65	14	274
NMS 40/125C	65	40	80	50	576	12	8	112	140	241	100	112	100	70	120	210	160	65	14	274
NMS 40/125A	65	40	80	50	576	12	8	112	140	241	100	112	100	70	120	210	160	65	14	274
NMS 40/160C	65	40	80	50	576	10	8	132	160	261	120	122	100	70	120	240	190	65	14	274
NMS 40/160B	65	40	80	50	590	10	8	132	160	270	120	122	100	70	120	240	190	65	14	274
NMS 40/160A	65	40	80	50	617	10	8	132	160	306	120	122	100	70	120	240	190	65	14	274
NMS 40/200D	65	40	100	50	637	12	8	160	180	334	141	141	100	70	120	265	212	65	14	274
NMS 40/200C	65	40	100	50	637	12	8	160	180	334	141	141	100	70	120	265	212	65	14	274
NMS 40/200D-S	65	40	100	50	666	12	8	160	180	320	141	141	100	70	250	265	212	130	14	407
NMS 40/200C-S	65	40	100	50	666	12	8	160	180	320	141	141	100	70	250	265	212	130	14	407
NMS 40/200B	65	40	100	50	666	12	8	160	180	320	141	141	100	70	250	265	212	130	14	407
NMS 40/200AR	65	40	100	50	666	12	8	160	180	320	141	141	100	70	250	265	212	130	14	407
NMS 40/200B-S	65	40	100	50	783	12	8	160	180	352	141	141	100	70	250	265	212	130	14	407
NMS 40/200AR-S	65	40	100	50	783	12	8	160	180	352	141	141	100	70	250	265	212	130	14	407
NMS 40/200A	65	40	100	50	783	12	8	160	180	352	141	141	100	70	250	265	212	130	14	407
NMS 40/125F	65	50	100	50	596	10	8	132	160	261	122	137	100	70	120	240	190	65	14	274
NMS 50/125D	65	50	100	50	610	10	8	132	160	270	122	137	100	70	120	240	190	65	14	274
NMS 50/125A	65	50	100	50	637	10	8	132	160	306	122	137	100	70	120	240	190	65	14	274
NMS 50/125S	65	50	100	50	637	10	8	132	160	306	122	137	100	70	120	240	190	65	14	274
NMS 50/160B	65	50	100	50	666	12	8	160	180	320	125	140	100	70	250	265	212	130	14	407
NMS 50/160A	65	50	100	50	783	12	8	160	180	352	125	140	100	70	250	265	212	130	14	407
NMS 65/125E	80	65	100	65	637	12	8	160	180	334	130	154	125	95	120	280	212	65	14	274
NMS 65/125C	80	65	100	65	666	12	8	160	180	320	130	154	125	95	250	280	212	130	14	407
NMS 65/125A	80	65	100	65	783	12	8	160	180	352	130	154	125	95	250	280	212	130	14	407
NMS 65/160D	80	65	100	65	783	12	8	160	200	352	140	161	125	95	250	280	212	130	14	407
NMS 80/160E	100	80	125	65	808	12	8	180	225	372	152	181	125	95	250	320	250	130	14	407

## Dimensions and weights with IE4 motor

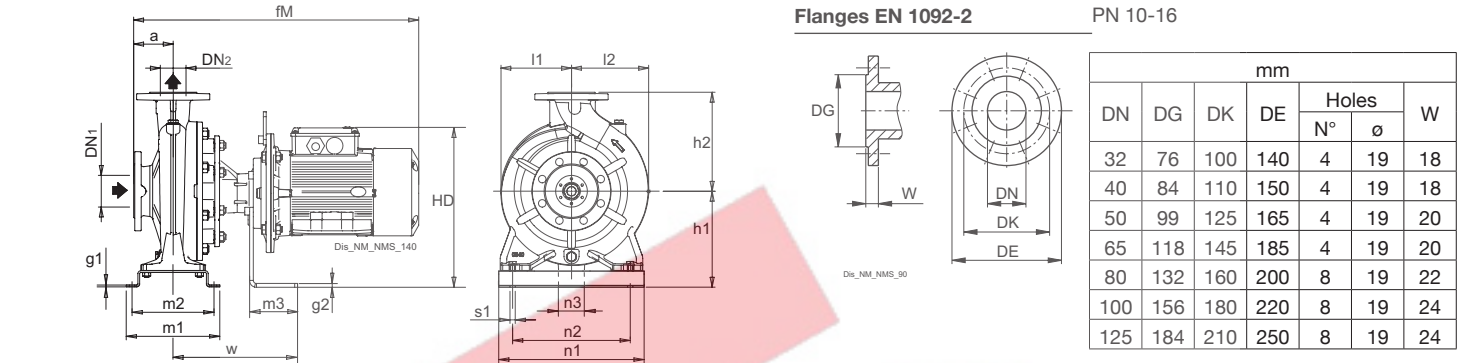

TYPE	DN1	DN2	mm																
			a	fM	g1	g2	h1	h2	HD	l1	l2	m1	m2	m3	n1	n2	n3	s1	w
NMS 40/160A-S	65	40	80	646	4	8	180	160	340	120	122	190	190	250	250	190	130	14	407
NMS 50/125S-S	65	50	100	666	4	8	180	160	340	122	137	190	190	250	250	190	130	14	407

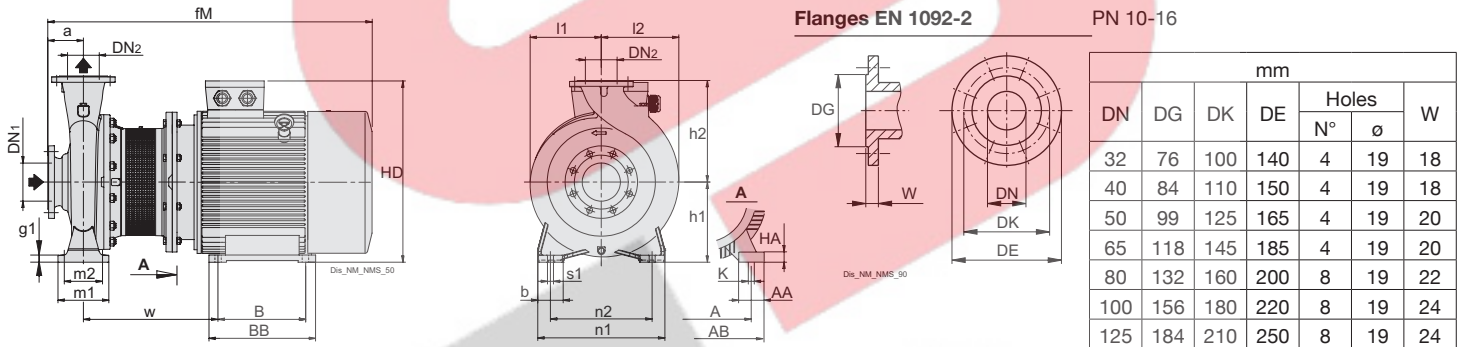

TYPE	DN1	DN2	mm																				kg		
			a	A	AA	AB	b	B	BB	fM	g1	h1	h2	HA	HD	K	l1	l2	m1	m2	n1	n2		s1	w
NMS 65/200A	80	65	100	279	70	350	65	241	315	915	12	180	225	22	450	15	159	179	125	95	320	250	14	394	-
NMS 65/250B/B	80	65	100	318	70	388	80	305	370	1001	15	200	250	25	500	19	178	195	160	120	360	280	18	406	-
NMS 65/250A/B	80	65	100	318	70	388	80	305	370	1001	15	200	250	25	500	19	178	195	160	120	360	280	18	406	-
NMS 80/200B/B	100	80	125	279	70	350	65	241	315	940	15	180	250	22	450	15	170	194	125	95	345	280	14	394	-
NMS 80/250D/A	100	80	125	318	70	388	80	305	370	1026	20	200	280	25	500	19	191	211	160	120	400	315	18	406	-
NMS 80/250C/A	100	80	125	318	70	388	80	305	370	1026	20	200	280	25	500	19	191	211	160	120	400	315	18	406	329.5
NMS 100/200C/A	125	100	125	318	70	388	80	305	370	1026	15	200	280	25	500	19	179	211	160	120	360	280	18	406	-
NMS 100/200B/A	125	100	125	318	70	388	80	305	370	1026	15	200	280	25	500	19	179	211	160	120	360	280	18	406	-

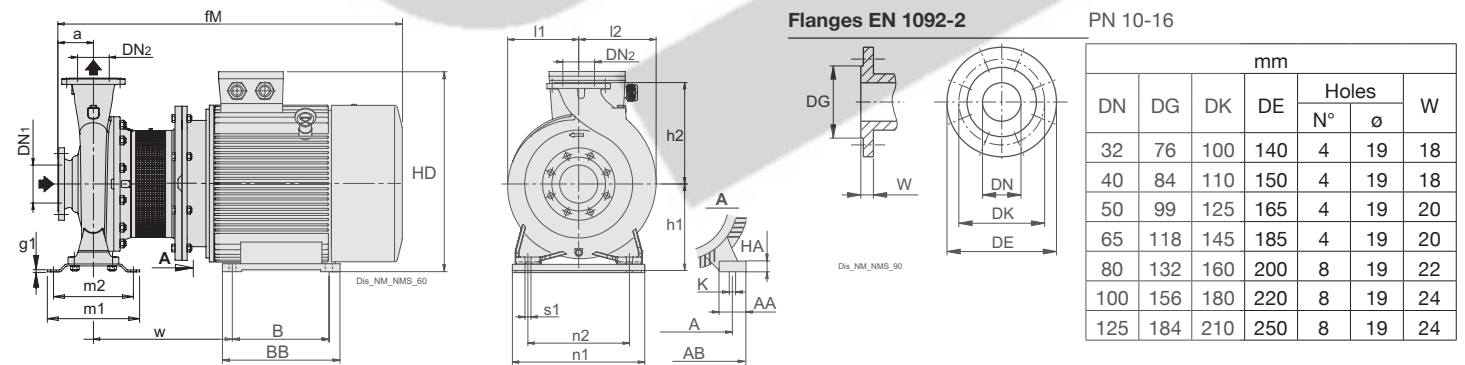

TYPE	DN1	DN2	mm																					
			a	A	AA	AB	B	BB	fM	g1	h1	h2	HA	HD	K	l1	l2	m1	m2	n1	n2	s1	w	
NMS 80/200A/B	100	80	125	318	70	388	305	370	1026	6	200	250	25	500	19	170	194	227	191	350	280	14	406	-
NMS 80/250B/A	100	80	125	356	75	431	311	395	1125	6	225	280	28	548	19	191	211	298	258	410	315	18	445	-
NMS 100/200A/A	125	100	125	356	75	431	311	395	1125	6	225	280	28	548	19	179	211	298	258	410	315	18	445	-
NMS 100/250A/A	125	100	140	457	85	545	368	490	1264	6	280	280	35	669	24	205	233	260	220	410	315	18	516	-

## Dimensions and weights with IE4 motor

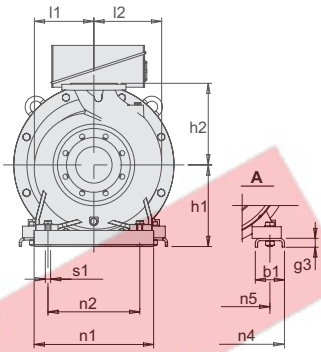
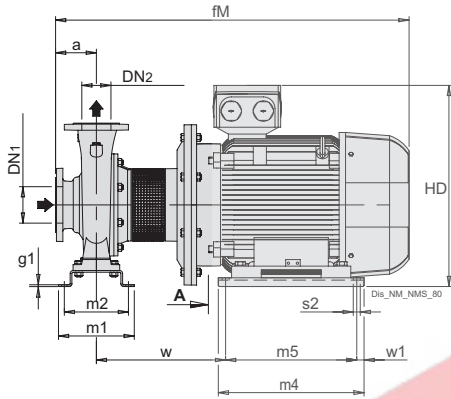

Flanges EN 1092-2

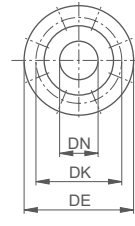
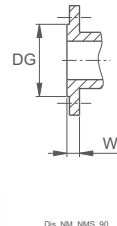

PN 10-16

DN	DG	DK	DE	Holes		W
				N°	ø	
32	76	100	140	4	19	18
40	84	110	150	4	19	18
50	99	125	165	4	19	20
65	118	145	185	4	19	20
80	132	160	200	8	19	22
100	156	180	220	8	19	24
125	184	210	250	8	19	24

TYPE	mm		mm																					
	DN1	DN2	a	b1	fM	g1	g3	h1	h2	HD	l1	l2	m1	m2	m4	m5	n1	n2	n4	n5	s1	s2	w	w1
NMS 50/200B	65	50	100	80	829	4	20	180	200	433	142	152	245	212	394	354	290	215	334	254	14	15	314	20
NMS 50/200A	65	50	100	80	829	4	20	180	200	433	142	152	245	212	394	354	290	215	334	254	14	15	314	20
NMS 50/200S	65	50	100	80	829	4	20	180	200	433	142	152	245	212	394	354	290	215	334	254	14	15	314	20
NMS 65/160C	80	65	100	80	829	4	20	180	200	433	140	161	245	212	394	354	290	215	334	254	14	15	314	20
NMS 65/160B	80	65	100	80	829	4	20	180	200	433	140	161	245	212	394	354	290	215	334	254	14	15	314	20
NMS 65/160AR	80	65	100	80	829	4	20	180	200	433	140	161	245	212	394	354	290	215	334	254	14	15	314	20
NMS 65/160A	80	65	100	80	829	4	20	180	200	433	140	161	245	212	394	354	290	215	334	254	14	15	314	20
NMS 80/250A/A	100	80	125	100	1187	6	30	280	280	642	191	211	260	220	570	520	410	315	506	406	18	24	408	25
NMS 100/250B/A	125	100	140	100	1202	6	30	280	280	642	205	233	260	220	570	520	410	315	506	406	18	24	408	25

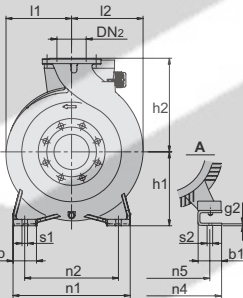
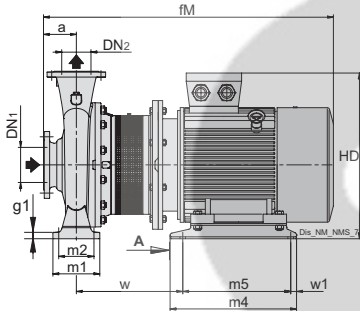

Flanges EN 1092-2

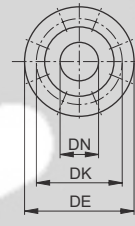
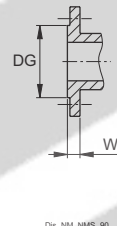

PN 10-16

DN	DG	DK	DE	Holes		W
				N°	ø	
32	76	100	140	4	19	18
40	84	110	150	4	19	18
50	99	125	165	4	19	20
65	118	145	185	4	19	20
80	132	160	200	8	19	22
100	156	180	220	8	19	24
125	184	210	250	8	19	24

TYPE	mm		mm																						
	DN1	DN2	a	b	b1	fM	g1	g3	h1	h2	HD	l1	l2	m1	m2	m4	m5	n1	n2	n4	n5	s1	s2	w	w1
NMS 40/250C	65	40	100	65	80	829	15	20	180	225	433	177	177	125	95	394	354	320	250	334	254	14	15	314	20
NMS 40/250B	65	40	100	65	80	829	15	20	180	225	433	177	177	125	95	394	354	320	250	334	254	14	15	314	20
NMS 40/250A	65	40	100	65	80	829	15	20	180	225	433	177	177	125	95	394	354	320	250	334	254	14	15	314	20
NMS 50/250C	65	50	100	65	80	829	15	20	180	225	433	177	177	125	95	394	354	320	250	334	254	14	15	314	20
NMS 50/250B	65	50	100	65	80	829	15	20	180	225	433	177	177	125	95	394	354	320	250	334	254	14	15	314	20
NMS 50/250A	65	50	100	65	80	873	15	20	180	225	433	177	177	125	95	394	354	320	250	334	254	14	15	314	20
NMS 65/200C	80	65	100	65	80	829	12	20	180	225	433	159	179	125	95	394	354	320	250	334	254	14	15	314	20
NMS 65/200B	80	65	100	65	80	873	12	20	180	225	433	159	179	125	95	394	354	320	250	334	254	14	15	314	20
NMS 65/250C	80	65	100	80	70	915	15	20	200	250	470	178	195	160	120	440	400	360	280	349	279	18	15	333	20
NMS 80/160D	100	80	125	65	80	854	12	20	180	225	433	152	181	125	95	394	354	320	250	334	254	14	15	314	20
NMS 80/160C	100	80	125	65	80	854	12	20	180	225	433	152	181	125	95	394	354	320	250	334	254	14	15	314	20
NMS 80/160B	100	80	125	65	80	854	12	20	180	225	433	152	181	125	95	394	354	320	250	334	254	14	15	314	20
NMS 80/160A	100	80	125	65	80	898	12	20	180	225	433	152	181	125	95	394	354	320	250	334	254	14	15	314	20
NMS 80/250E	100	80	125	80	70	940	20	20	200	280	470	191	211	160	120	440	400	400	315	349	279	18	15	333	20
NMS 100/200E	125	100	125	80	60	923	15	40	200	280	453	179	211	160	120	394	354	360	280	314	254	18	15	339	20
NMS 100/200D/A	125	100	125	80	70	940	15	20	200	280	470	179	211	160	120	440	400	360	280	349	279	18	15	333	20

## Dimensions and weights

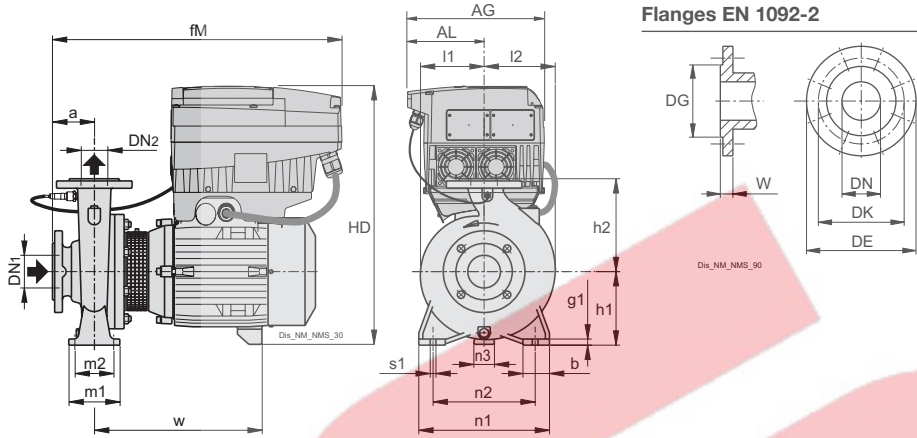

Flanges EN 1092-2

PN 10-16

DN	DG	DK	DE	Holes		W
				N°	ø	
32	76	100	140	4	19	18
40	84	110	150	4	19	18
50	99	125	165	4	19	20
65	118	145	185	4	19	20
80	132	160	200	8	19	22
100	156	180	220	8	19	24
125	184	210	250	8	19	24

TYPE	DN1	DN2	mm																		kg
			a	AG	AL	b	fM	g1	h1	h2	HD	l1	l2	m1	m2	n1	n2	n3	s1	w	
NM EI 32/12FE	50	32	80	190	105	50	408	12	112	140	397	93	98	100	70	190	140	31	14	248	30.2
NM EI 32/12DE	50	32	80	190	105	50	408	12	112	140	397	93	98	100	70	190	140	31	14	248	-
NM EI 32/12A/A	50	32	80	190	105	50	408	12	112	140	397	93	98	100	70	190	140	31	14	248	32.7
NM EI 32/12S/A	50	32	80	190	105	50	408	12	112	140	397	93	98	100	70	190	140	31	14	248	33.8
NM EI 32/16B/A	50	32	80	190	105	50	413	12	132	160	417	119	119	100	70	240	190	35	14	255	-
NM EI 32/16A/B	50	32	80	210	118	50	453	12	132	160	417	119	119	100	70	240	190	35	14	295	-
NM EI 32/20D/B	50	32	80	210	118	50	453	12	160	180	445	140	140	100	70	240	190	40	14	297	-
NM EI 32/20C/A	50	32	80	210	118	50	479	12	160	180	455	140	140	100	70	240	190	37	14	297	55.2
NM EI 32/20A/B	50	32	80	210	118	50	479	12	160	180	455	140	140	100	70	240	190	37	14	297	58.7
NM EI 32L/16C	50	32	80	210	118	50	453	10	132	160	417	121	121	100	70	240	190	35	14	295	43
NM EI 32L/16B	50	32	80	210	118	50	479	10	132	160	427	121	121	100	70	240	190	32	14	294	51.2
NM EI 32L/16A	50	32	80	210	118	50	479	10	132	160	427	121	121	100	70	240	190	32	14	294	54.3
NM EI 32L/20C	50	32	80	210	118	50	479	12	160	180	455	142	142	100	70	240	190	37	14	297	57.9
NM EI 32L/20B	50	32	80	210	118	50	539	12	160	180	484	142	142	100	70	240	190	34	14	335	-
NM EI 32L/20A	50	32	80	281	154	50	539	12	160	180	526	142	142	100	70	240	190	34	14	335	-
NM EI 40/12F/B	65	40	80	190	105	50	413	12	112	140	397	100	112	100	70	210	160	31	14	253	34.8
NM EI 40/12C/B	65	40	80	190	105	50	413	12	112	140	397	100	112	100	70	210	160	31	14	253	36.5
NM EI 40/12A/C	65	40	80	210	118	50	453	12	112	140	397	100	112	100	70	210	160	31	14	293	40
NM EI 40/16C/C	65	40	80	210	118	50	453	10	132	160	417	120	122	100	70	240	190	35	14	295	-
NM EI 40/16B/B	65	40	80	210	118	50	479	10	132	160	427	120	122	100	70	240	190	32	14	294	52
NM EI 40/16A/C	65	40	80	210	118	50	479	10	132	160	427	120	122	100	70	240	190	32	14	294	55.5
NM EI 40/20D/B	65	40	100	210	118	50	499	12	160	180	455	141	141	100	70	265	212	37	14	297	-
NM EI 40/20C/B	65	40	100	210	118	50	499	12	160	180	455	141	141	100	70	265	212	37	14	297	-
NM EI 40/20B/A	65	40	100	210	118	50	559	12	160	180	484	141	141	100	70	265	212	34	14	335	74.5
NM EI 40/20AR/A	65	40	100	210	118	50	559	12	160	180	484	141	141	100	70	265	212	34	14	335	73.1
NM EI 40/20A/A	65	40	100	281	154	50	559	12	160	180	526	141	141	100	70	265	212	34	14	335	86
NM EI 40/25C/C	65	40	100	281	154	65	639	15	180	225	569	177	177	125	95	320	250	35	14	397	123
NM EI 40/25B/C	65	40	100	281	154	65	639	15	180	225	569	177	177	125	95	320	250	35	14	397	131
NM EI 40/25A/C	65	40	100	350	190	65	714	15	180	225	649	177	177	125	95	320	250	35	14	472	-
NM EI 50/12F/C	65	50	100	210	118	50	473	10	132	160	417	122	137	100	70	240	190	35	14	295	45.5
NM EI 50/12D/B	65	50	100	210	118	50	499	10	132	160	427	122	137	100	70	240	190	32	14	294	52.6
NM EI 50/12A/C	65	50	100	210	118	50	499	10	132	160	427	122	137	100	70	240	190	32	14	294	-
NM EI 50/12S/C	65	50	100	210	118	50	499	10	132	160	427	122	137	100	70	240	190	32	14	294	56.1
NM EI 50/16B/B	65	50	100	210	118	50	559	12	160	180	484	125	140	100	70	265	212	34	14	335	73
NM EI 50/16A/B	65	50	100	281	154	50	559	12	160	180	526	125	140	100	70	265	212	34	14	335	85.5
NM EI 50/20B/C	65	50	100	281	154	50	639	14	160	200	549	142	152	100	70	265	212	31	14	395	115
NM EI 50/20A/C	65	50	100	281	154	50	639	14	160	200	549	142	152	100	70	265	212	31	14	395	123
NM EI 50/20S/C	65	50	100	350	190	50	714	14	160	200	629	142	152	100	70	265	212	31	14	470	163.2
NM EI 50/25C/C	65	50	100	281	154	65	644	15	180	225	569	177	177	125	95	320	250	35	14	402	135.1
NM EI 50/25B/C	65	50	100	350	190	65	719	15	180	225	649	177	177	125	95	320	250	35	14	477	175.5
NM EI 65/12E/C	80	65	100	210	118	65	504	12	160	180	455	130	154	125	95	280	212	37	14	302	59
NM EI 65/12C/B	80	65	100	210	118	65	564	12	160	180	484	130	154	125	95	280	212	34	14	340	-
NM EI 65/12A/B	80	65	100	281	154	65	564	12	160	180	526	130	154	125	95	280	212	34	14	340	-
NM EI 65/16D/B	80	65	100	281	154	65	559	12	160	200	526	140	161	125	95	280	212	34	14	335	87
NM EI 65/16C/C	80	65	100	281	154	65	639	12	160	200	549	140	161	125	95	280	212	31	14	395	108.8
NM EI 65/16B/C	80	65	100	281	154	65	639	12	160	200	549	140	161	125	95	280	212	31	14	395	135
NM EI 65/16AR	80	65	100	350	190	65	714	12	160	200	629	140	161	125	95	280	212	31	14	470	-
NM EI 65/16A/C	80	65	100	350	190	65	714	12	160	200	629	140	161	125	95	280	212	31	14	470	156.8
NM EI 65/20C/C	80	65	100	350	190	65	714	12	180	225	649	159	179	125	95	320	250	35	14	472	168.5
NM EI 80/16E/B	100	80	125	281	154	65	584	12	180	225	546	152	181	125	95	320	250	37	14	337	-
NM EI 80/16D/C	100	80	125	281	154	65	669	12	180	225	569	152	181	125	95	320	250	35	14	402	-
NM EI 80/16C/C	100	80	125	281	154	65	669	12	180	225	569	152	181	125	95	320	250	35	14	402	124.6
NM EI 80/16B/C	100	80	125	350	190	65	744	12	180	225	649	152	181	125	95	320	250	35	14	477	168

## Dimensions and weights

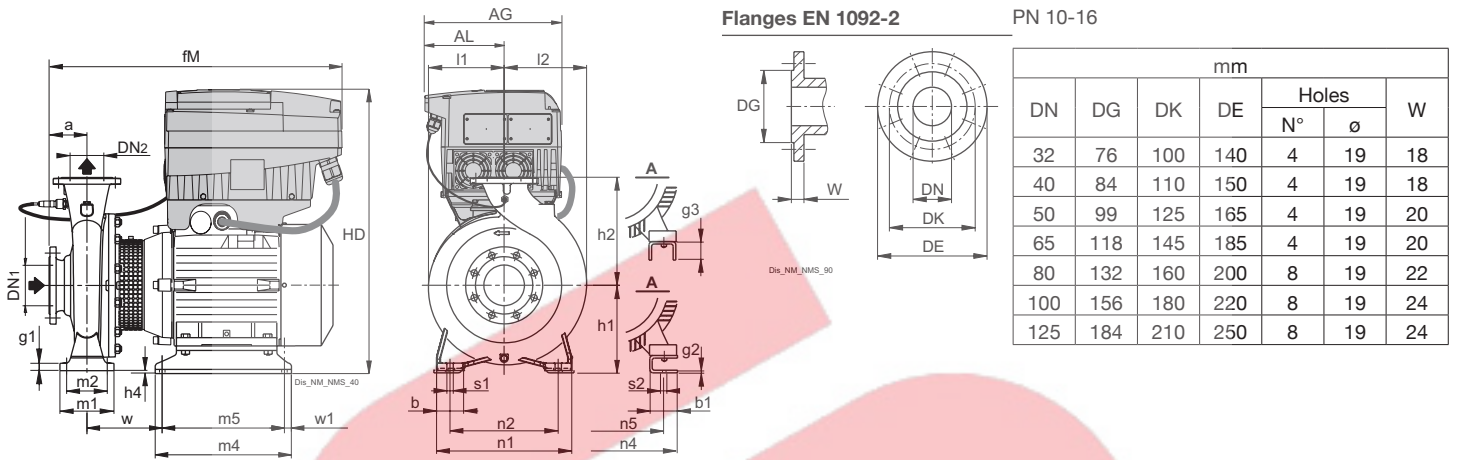

TYPE	mm																										kg		
	DN1	DN2	a	AG	AL	b	b1	fM	g1	g3	h1	h2	h4	HD	l1	l2	m1	m2	m4	m5	n1	n2	n4	n5	s1	s2	w	w1	Weight
NM EI 50/25A/D	65	50	100	350	190	65	80	765	15	20	180	225	-	674	177	177	125	95	394	354	320	250	334	254	14	15	185	20	205
NM EI 50/25S	65	50	100	350	190	65	80	765	15	20	180	225	-	674	177	177	125	95	394	354	320	250	334	254	14	15	185	20	-
NM EI 65/20B/D	80	65	100	350	190	65	80	765	12	20	180	225	-	674	159	179	125	95	394	354	320	250	334	254	14	15	185	20	204
NM EI 65/20A/A	80	65	100	350	190	65	80	765	12	20	180	225	-	674	159	179	125	95	394	354	320	250	334	254	14	15	185	20	206.5
NM EI 65/25C/A	80	65	100	350	190	80	90	765	15	42	200	250	2	694	178	195	160	120	400	360	360	280	344	254	18	14	182	20	230
NM EI 80/16A/D	100	80	125	350	190	65	80	790	12	20	180	225	-	674	152	181	125	95	394	354	320	250	334	254	14	15	185	20	-
NM EI 80/20B/A	100	80	125	350	190	65	90	790	15	42	180	250	22	674	170	194	125	95	400	360	345	280	344	254	14	14	182	20	-
NM EI 80/25E	100	80	125	350	190	80	90	790	20	42	200	280	2	694	191	211	160	120	400	360	400	315	344	254	18	14	182	20	-
NM EI 100/20E/A	125	100	125	350	190	80	60	790	15	40	200	280	-	694	179	211	160	120	394	354	360	280	314	254	18	15	185	20	213.5
NM EI 100/20D	125	100	125	350	190	80	60	790	15	40	200	280	-	694	179	211	160	120	394	354	360	280	314	254	18	15	185	20	-

## Dimensions and weights

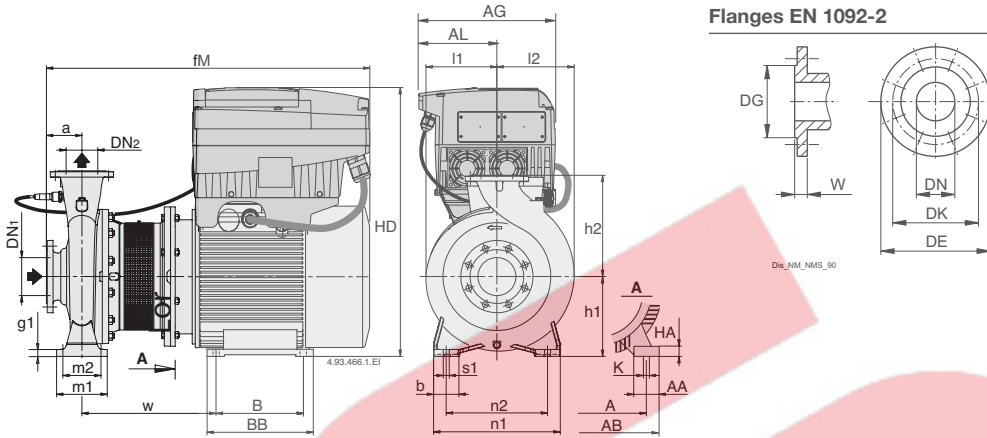

Flanges EN 1092-2

PN 10-16

DN	DG	DK	DE	Holes		W
				N°	ø	
32	76	100	140	4	19	18
40	84	110	150	4	19	18
50	99	125	165	4	19	20
65	118	145	185	4	19	20
80	132	160	200	8	19	22
100	156	180	220	8	19	24
125	184	210	250	8	19	24

TYPE	DN1	DN2	mm																							kg	
			a	A	AA	AB	AG	AL	b	B	BB	fM	g1	h1	h2	HA	HD	K	l1	l2	m1	m2	n1	n2	s1		w
NMS EI 65/250A/B	80	65	100	318	70	390	350	190	80	305	355	1009	15	200	250	25	783	18.5	178	195	160	120	360	280	18	406	-
NMS EI 80/200A/A	100	80	125	279	65	339	350	190	65	279	328	986	15	180	250	20	719	14.5	170	194	125	95	345	280	14	394	-
NMS EI 80/250C/A	100	80	125	318	70	390	350	190	80	305	355	1034	20	200	280	25	783	18.5	191	211	160	120	400	315	18	406	-
NMS EI 100/200B/A	125	100	125	318	70	390	350	190	80	305	355	1034	15	200	280	25	783	18.5	179	211	160	120	360	280	18	406	330.5

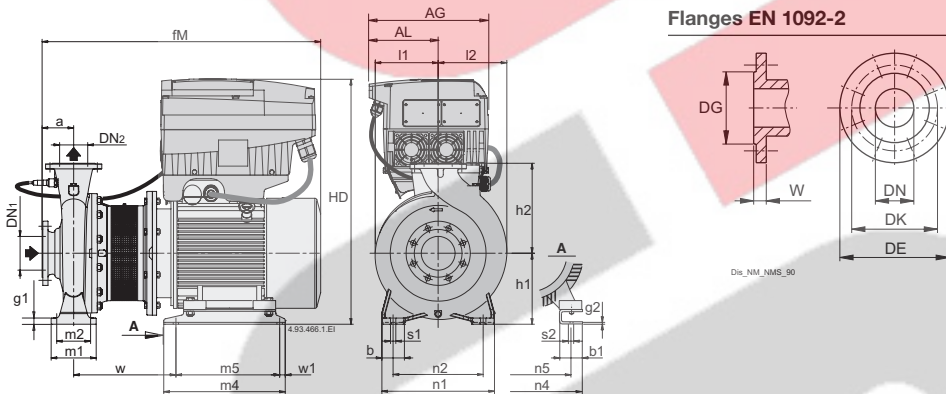

Flanges EN 1092-2

PN 10-16

DN	DG	DK	DE	Holes		W
				N°	ø	
32	76	100	140	4	19	18
40	84	110	150	4	19	18
50	99	125	165	4	19	20
65	118	145	185	4	19	20
80	132	160	200	8	19	22
100	156	180	220	8	19	24
125	184	210	250	8	19	24

TYPE	DN1	DN2	mm																							kg		
			a	AG	AL	b	b1	fM	g1	g2	h1	h2	HD	l1	l2	m1	m2	m4	m5	n1	n2	n4	n5	s1	s2		w	w1
NMS EI 65/250B/A	80	65	100	350	190	80	70	961	15	20	200	250	739	178	195	160	120	440	400	360	280	349	279	18	14.5	394	20	-
NMS EI 80/250D	100	80	125	350	190	80	70	986	20	20	200	280	739	191	211	160	120	440	400	400	315	349	279	18	14.5	394	20	283.5
NMS EI 100/200C	125	100	125	350	190	80	70	986	15	20	200	280	739	179	211	160	120	440	400	360	280	349	279	18	14.5	394	20	-

## Dimensions and weights

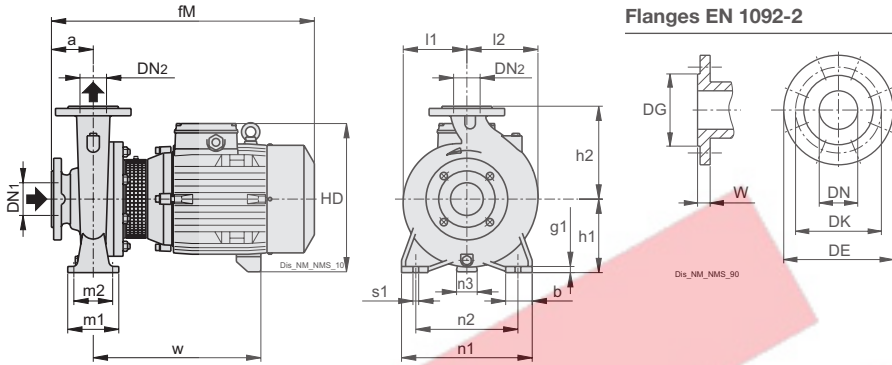

Flanges EN 1092-2

PN 10-16

DN	DG	DK	DE	Holes		W
				N°	ø	
32	76	100	140	4	19	18
40	84	110	150	4	19	18
50	99	125	165	4	19	20
65	118	145	185	4	19	20
80	132	160	200	8	19	22
100	156	180	220	8	19	24
125	184	210	250	8	19	24

TYPE	DN1	DN2	mm															kg Weight	
			a	b	fM	g1	h1	h2	HD	l1	l2	m1	m2	n1	n2	n3	s1		w
BNM 32/12F	50	32	80	50	408	12	112	140	242	93	98	100	70	190	140	31	14	248	25.9
BNM 32/12D	50	32	80	50	408	12	112	140	242	93	98	100	70	190	140	31	14	248	26.1
BNM 32/12A/A	50	32	80	50	408	12	112	140	242	93	98	100	70	190	140	31	14	248	28.2
BNM 32/12S/A	50	32	80	50	408	12	112	140	242	93	98	100	70	190	140	31	14	248	29.2
BNM 32/16B/A	50	32	80	50	413	12	132	160	262	119	119	100	70	240	190	35	14	255	39.2
BNM 32/16A/B	50	32	80	50	453	12	132	160	262	119	119	100	70	240	190	35	14	295	41.6
BNM 32/20D/B	50	32	80	50	453	12	160	180	290	140	140	100	70	240	190	40	14	297	44.7
BNM 32/20C/A	50	32	80	50	479	12	160	180	300	140	140	100	70	240	190	37	14	297	56.5
BNM 32/20A/B	50	32	80	50	479	12	160	180	300	140	140	100	70	240	190	37	14	297	56.5
BNM 32L/20C	50	32	80	50	479	12	160	180	300	142	142	100	70	240	190	37	14	297	-
BNM 32L/200B	50	32	80	50	594	12	160	180	327	142	142	100	70	240	190	34	14	390	-
BNM 32L/200A	50	32	80	50	594	12	160	180	327	142	142	100	70	240	190	34	14	390	76.6
BNM 32L/16C	50	32	80	50	453	10	132	160	262	121	121	100	70	240	190	35	14	295	39.2
BNM 32L/16B	50	32	80	50	479	10	132	160	272	121	121	100	70	240	190	32	14	294	46.2
BNM 32L/16A	50	32	80	50	479	10	132	160	272	121	121	100	70	240	190	32	14	294	49.7
BNM 40/12F/A	65	40	80	50	413	12	112	140	242	100	112	100	70	210	160	31	14	253	31.2
BNM 40/12C/A	65	40	80	50	413	12	112	140	242	100	112	100	70	210	160	31	14	253	32.5
BNM 40/12A/B	65	40	80	50	453	12	112	140	242	100	112	100	70	210	160	31	14	293	32.6
BNM 40/16C/B	65	40	80	50	453	10	132	160	262	120	122	100	70	240	190	35	14	295	43
BNM 40/16B/A	65	40	80	50	479	10	132	160	272	120	122	100	70	240	190	32	14	294	50.2
BNM 40/16A/B	65	40	80	50	479	10	132	160	272	120	122	100	70	240	190	32	14	294	53.4
BNM 40/20D/B	65	40	100	50	499	12	160	180	300	141	141	100	70	265	212	37	14	297	59.6
BNM 40/20C/B	65	40	100	50	499	12	160	180	300	141	141	100	70	265	212	37	14	297	60.2
BNM 40/200B/A	65	40	100	50	614	12	160	180	327	141	141	100	70	265	212	34	14	390	75.6
BNM 40/200AR/A	65	40	100	50	614	12	160	180	327	141	141	100	70	265	212	34	14	390	-
BNM 40/200A/A	65	40	100	50	614	12	160	180	327	141	141	100	70	265	212	34	14	390	80.6
BNM 50/12F/B	65	50	100	50	473	10	132	160	262	122	137	100	70	240	190	35	14	295	42.9
BNM 50/12D/A	65	50	100	50	499	10	132	160	272	122	137	100	70	240	190	32	14	294	50.6
BNM 50/12A/B	65	50	100	50	499	10	132	160	272	122	137	100	70	240	190	32	14	294	53.3
BNM 50/12S/B	65	50	100	50	499	10	132	160	272	122	137	100	70	240	190	32	14	294	53.8
BNM 50/160B/B	65	50	100	50	614	12	160	180	327	125	140	100	70	265	212	34	14	390	73.7
BNM 50/160A/B	65	50	100	50	614	12	160	180	327	125	140	100	70	265	212	34	14	390	79.6
BNM 65/12E/A	80	65	100	65	504	12	160	180	300	130	154	125	95	280	212	37	14	302	57.6
BNM 65/125C/B	80	65	100	65	619	12	160	180	327	130	154	125	95	280	212	34	14	395	74.9
BNM 65/125A/B	80	65	100	65	619	12	160	180	327	130	154	125	95	280	212	34	14	395	80.3
BNM 65/160D/B	80	65	100	65	614	12	160	200	327	140	161	125	95	280	212	34	14	390	81.6
BNM 65/160C/C	80	65	100	65	659	12	160	200	350	140	161	125	95	280	212	31	14	415	102
BNM 80/160E/B	100	80	125	65	639	12	180	225	347	152	181	125	95	320	250	37	14	392	-
BNM 80/160D/C	100	80	125	65	684	12	180	225	370	152	181	125	95	320	250	35	14	417	109.2

TYPE	DN1	DN2	mm															kg Weight	
			a	b	fM	g1	h1	h2	HD	l1	l2	m1	m2	n1	n2	n3	s1		w
BNMM 32/12S	50	32	80	50	408	12	112	140	242	93	98	100	70	190	140	31	14	248	-
BNMM 32/12F	50	32	80	50	408	12	112	140	242	93	98	100	70	190	140	31	14	248	26.8
BNMM 32/12D	50	32	80	50	408	12	112	140	242	93	98	100	70	190	140	31	14	248	-
BNMM 32/12A	50	32	80	50	408	12	112	140	242	93	98	100	70	190	140	31	14	248	29.6

Version without coupling guard  
 BNM 40/200A/A-AR/A-B/A  
 BNM 50/160A/B-B/B  
 BNM 65/125A/B-C/B  
 BNM 65/160 D/B-C/C  
 BNM 80/160E/B-D/C

## Dimensions and weights

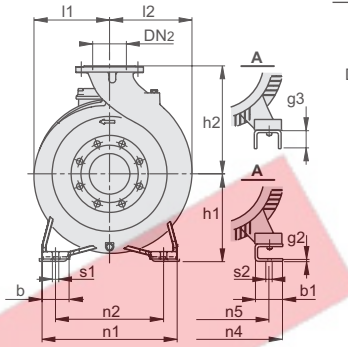
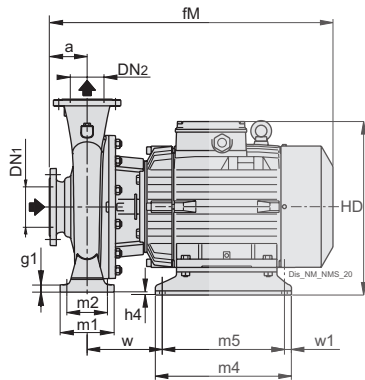

Flanges EN 1092-2

PN 10-16

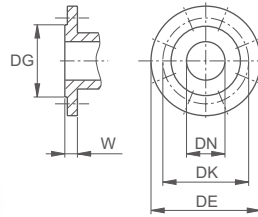

mm						
DN	DG	DK	DE	Holes		W
				N°	ø	
32	76	100	140	4	19	18
40	84	110	150	4	19	18
50	99	125	165	4	19	20
65	118	145	185	4	19	20
80	132	160	200	8	19	22
100	156	180	220	8	19	24
125	184	210	250	8	19	24

TYPE	mm																										kg	
	DN1	DN2	a	b	b1	fM	g1	g2	g3	h1	h2	h4	HD	l1	l2	m1	m2	m4	m5	n1	n2	n4	n5	s1	s2	w		w1
BNM 4025/C/C	65	40	100	65	69	634	15	6	-	180	225	12	370	177	177	125	95	298	258	320	250	266	216	14	12	174	20	-
BNM 4025/B/C	65	40	100	65	69	634	15	6	-	180	225	12	370	177	177	125	95	298	258	320	250	266	216	14	12	174	20	129
BNM 4025/A/C	65	40	100	65	69	709	15	6	-	180	225	12	370	177	177	125	95	298	258	320	250	266	216	14	12	174	20	-
BNM 50/200B/C	65	50	100	50	69	694	14	6	-	160	200	32	350	142	152	100	70	298	258	265	212	266	216	14	12	234	20	124.9
BNM 50/200A/C	65	50	100	50	69	694	14	6	-	160	200	32	350	142	152	100	70	298	258	265	212	266	216	14	12	234	20	132.8
BNM 50/200S/C	65	50	100	50	69	769	14	6	-	160	200	32	350	142	152	100	70	298	258	265	212	266	216	14	12	234	20	151.3
BNM 5025/C/C	65	50	100	65	69	634	15	6	-	180	225	12	370	177	177	125	95	298	258	320	250	266	216	14	12	174	20	133.9
BNM 5025/B/C	65	50	100	65	69	709	15	6	-	180	225	12	370	177	177	125	95	298	258	320	250	266	216	14	12	174	20	-
BNM 50/25A	65	50	100	65	80	765	15	-	20	180	225	-	388	177	177	125	95	394	354	320	250	334	254	14	15	185	20	-
BNM 50/25S	65	50	100	65	80	765	15	-	20	180	225	-	388	177	177	125	95	394	354	320	250	334	254	14	15	185	20	189.8
BNM 65/160B/C	80	65	100	65	69	694	12	6	-	160	200	32	350	140	161	125	95	298	258	280	212	266	216	14	12	234	20	129.2
BNM 65/160AR	80	65	100	65	69	769	12	6	-	160	200	32	350	140	161	125	95	298	258	280	212	266	216	14	12	234	20	-
BNM 65/160A/C	80	65	100	65	69	769	12	6	-	160	200	32	350	140	161	125	95	298	258	280	212	266	216	14	12	234	20	-
BNM 65/200C/C	80	65	100	65	69	774	12	6	-	180	225	12	370	159	179	125	95	298	258	320	250	266	216	14	12	239	20	156.6
BNM 65/250C/B	80	65	100	80	90	828	15	-	42	200	250	2	408	178	195	160	120	400	360	360	280	344	254	18	14	245	20	-
BNM 80/160C/C	100	80	125	65	69	724	12	6	-	180	225	12	370	152	181	125	95	298	258	320	250	266	216	14	12	239	20	138.6
BNM 80/160B/C	100	80	125	65	69	799	12	6	-	180	225	12	370	152	181	125	95	298	258	320	250	266	216	14	12	239	20	157.4
BNM 80/16A	100	80	125	65	80	790	12	-	20	180	225	-	388	152	181	125	95	394	354	320	250	334	254	14	15	185	20	169

## Dimensions and weights with IE3 motor

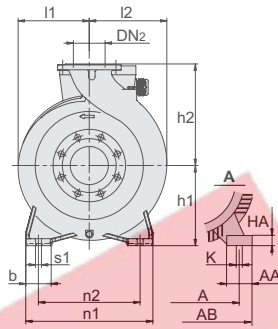
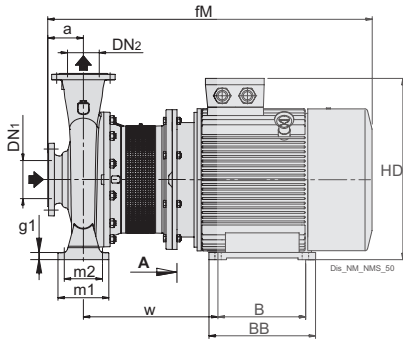

Flanges EN 1092-2

PN 10-16

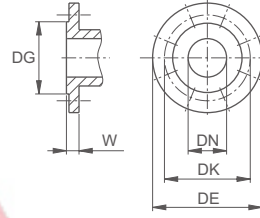

mm						
DN	DG	DK	DE	Holes		W
				N°	ø	
32	76	100	140	4	19	18
40	84	110	150	4	19	18
50	99	125	165	4	19	20
65	118	145	185	4	19	20
80	132	160	200	8	19	22
100	156	180	220	8	19	24
125	184	210	250	8	19	24

TYPE			mm																					
	DN1	DN2	a	A	AA	AB	b	B	BB	fM	g1	h1	h2	HA	HD	K	l1	l2	m1	m2	n1	n2	s1	w
BNMS 65/200A	80	65	100	279	70	350	65	241	312	955	12	180	225	22	450	15	159	179	125	95	320	250	14	394
BNMS 65/250A/B	80	65	100	318	70	390	80	305	370	1006	15	200	250	25	500	19	178	195	160	120	360	280	18	406
BNMS 65/250B/B	80	65	100	318	70	390	80	305	370	1006	15	200	250	25	500	19	178	195	160	120	360	280	18	406
BNMS 80/200B/B	100	80	125	279	70	350	65	241	312	980	15	180	250	22	450	15	170	194	125	95	345	280	14	394
BNMS 80/250C/A	100	80	125	318	70	390	80	305	370	1031	20	200	280	25	500	19	191	211	160	120	400	315	18	406
BNMS 80/250D/A	100	80	125	318	70	390	80	305	370	1031	20	200	280	25	500	19	191	211	160	120	400	315	18	406
BNMS 100/200B/A	125	100	125	318	70	390	80	305	370	1031	15	200	280	25	500	19	179	211	160	120	360	280	18	406
BNMS 100/200C/A	125	100	125	318	70	390	80	305	370	1031	15	200	280	25	500	19	179	211	160	120	360	280	18	406

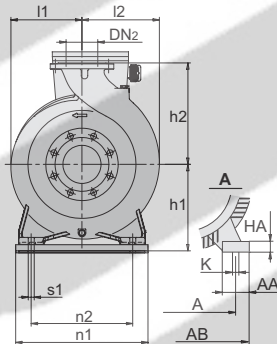
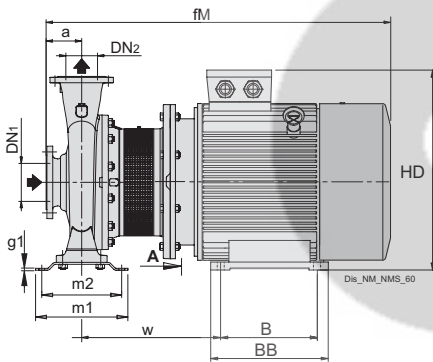

Flanges EN 1092-2

PN 10-16

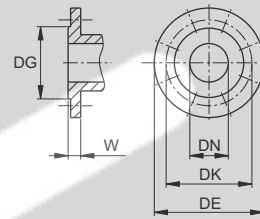

mm						
DN	DG	DK	DE	Holes		W
				N°	ø	
32	76	100	140	4	19	18
40	84	110	150	4	19	18
50	99	125	165	4	19	20
65	118	145	185	4	19	20
80	132	160	200	8	19	22
100	156	180	220	8	19	24
125	184	210	250	8	19	24

TYPE			mm																				
	DN1	DN2	a	A	AA	AB	B	BB	fM	g1	h1	h2	HA	HD	K	l1	l2	m1	m2	n1	n2	s1	w
BNMS 80/200A/B	100	80	125	318	70	390	305	370	1031	6	200	250	25	500	19	170	194	227	191	350	280	14	406
BNMS 80/250B/A	100	80	125	356	75	431	311	395	1089	6	225	280	28	555	19	191	211	298	258	410	315	18	445
BNMS 100/200A/A	125	100	125	356	75	431	311	395	1089	6	225	280	28	555	19	179	211	298	258	410	315	18	445
BNMS 100/250A/A	125	100	140	457	85	545	368	485	1276	6	280	280	38	670	24	205	233	260	220	410	315	18	516

## Dimensions and weights with IE3 motor

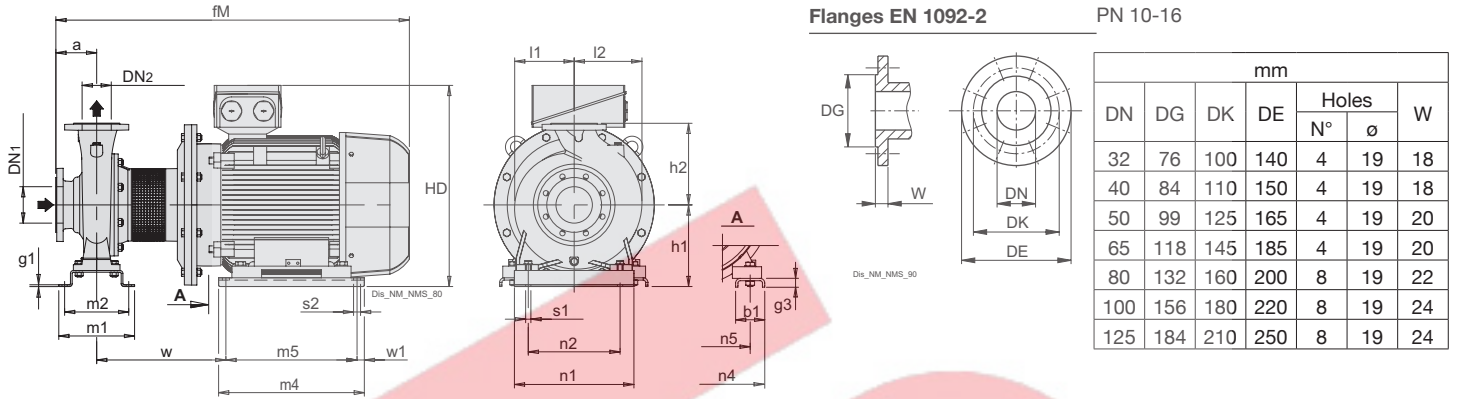

TYPE	DN1	DN2	mm																		kg			
			a	fM	g1	g3	h1	h2	HD	l1	l2	m1	m2	m4	m5	n1	n2	n4	n5	s1		s2	w	w1
BNMS 80/250A/A	100	80	125	1321	6	30	280	280	642	191	211	260	220	570	520	410	315	506	406	18	24	408	25	524
BNMS 100/250B/A	125	100	140	1336	6	30	280	280	642	205	233	260	220	570	520	410	315	506	406	18	24	408	25	-

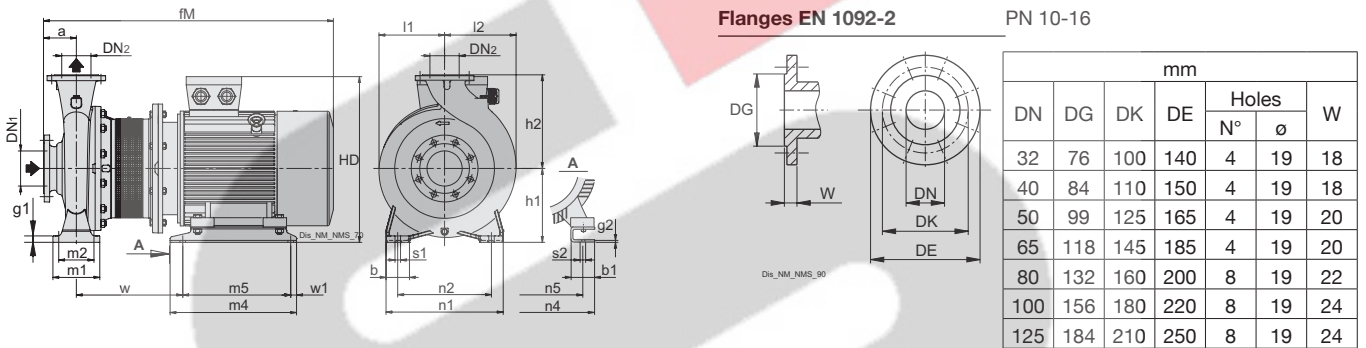

TYPE	DN1	DN2	mm																						
			a	b	b1	fM	g1	g3	h1	h2	HD	l1	l2	m1	m2	m4	m5	n1	n2	n4	n5	s1	s2	w	w1
BNMS 65/250C	80	65	100	80	70	955	15	20	200	250	470	178	195	160	120	440	400	360	280	349	279	18	15	333	20
BNMS 80/250E	100	80	125	80	70	980	20	20	200	280	470	191	211	160	120	440	400	400	315	349	279	18	15	333	20
BNMS 100/200D/A	125	100	125	80	70	980	15	20	200	280	470	179	211	160	120	440	400	360	280	349	279	18	15	333	20

## Dimensions and weights with IE4 motor

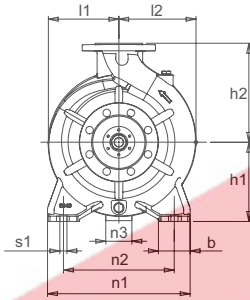
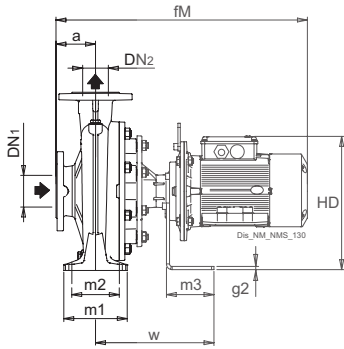

Flanges EN 1092-2

PN 10-16

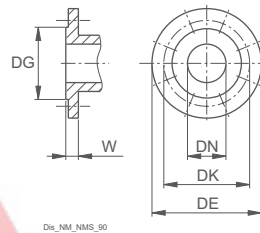

mm						
DN	DG	DK	DE	Holes		W
				N°	ø	
32	76	100	140	4	19	18
40	84	110	150	4	19	18
50	99	125	165	4	19	20
65	118	145	185	4	19	20
80	132	160	200	8	19	22
100	156	180	220	8	19	24
125	184	210	250	8	19	24

TYPE	mm																			
	DN1	DN2	a	b	fM	g1	g2	h1	h2	HD	l1	l2	m1	m2	m3	n1	n2	n3	s1	w
BNMS 32/125D	50	32	80	50	536	12	8	112	140	241	93	98	100	70	120	190	140	65	14	274
BNMS 32/125D-S	50	32	80	50	536	12	8	112	140	241	93	98	100	70	120	190	140	65	14	274
BNMS 32/125A	50	32	80	50	536	12	8	112	140	241	93	98	100	70	120	190	140	65	14	274
BNMS 32/125S	50	32	80	50	576	12	8	112	140	241	93	98	100	70	120	190	140	65	14	274
BNMS 32/125A-S	50	32	80	50	576	12	8	112	140	241	93	98	100	70	120	190	140	65	14	274
BNMS 32/160B	50	32	80	50	576	12	8	132	160	261	119	119	100	70	120	240	190	65	14	274
BNMS 32/160B-S	50	32	80	50	576	12	8	132	160	261	119	119	100	70	120	240	190	65	14	274
BNMS 32/160A	50	32	80	50	576	12	8	132	160	261	119	119	100	70	120	240	190	65	14	274
BNMS 32/160A-S	50	32	80	50	590	12	8	132	160	270	119	119	100	70	120	240	190	65	14	274
BNMS 32/200D	50	32	80	50	576	12	8	160	180	289	140	140	100	70	120	240	190	65	14	274
BNMS 32/200D-S	50	32	80	50	590	12	8	160	180	298	140	140	100	70	120	240	190	65	14	274
BNMS 32/200C	50	32	80	50	590	12	8	160	180	298	140	140	100	70	120	240	190	65	14	274
BNMS 32/200A	50	32	80	50	617	12	8	160	180	334	140	140	100	70	120	240	190	65	14	274
BNMS 32/200A-S	50	32	80	50	646	12	8	160	180	320	140	140	100	70	250	240	190	130	14	407
BNMS 32L/160C	50	32	80	50	576	10	8	132	160	261	121	121	100	70	120	240	190	65	14	274
BNMS 32L/160B	50	32	80	50	590	10	8	132	160	270	121	121	100	70	120	240	190	65	14	274
BNMS 32L/160A	50	32	80	50	617	10	8	132	160	306	121	121	100	70	120	240	190	65	14	274
BNMS 32L/200C	50	32	80	50	617	12	8	160	180	334	142	142	100	70	120	240	190	65	14	274
BNMS 32L/200B	50	32	80	50	646	12	8	160	180	320	142	142	100	70	250	240	190	130	14	407
BNMS 32L/200A	50	32	80	50	763	12	8	160	180	352	142	142	100	70	250	240	190	130	14	407
BNMS 40/125F	65	40	80	50	536	12	8	112	140	241	100	112	100	70	120	210	160	65	14	274
BNMS 40/125C	65	40	80	50	576	12	8	112	140	241	100	112	100	70	120	210	160	65	14	274
BNMS 40/125A	65	40	80	50	576	12	8	112	140	241	100	112	100	70	120	210	160	65	14	274
BNMS 40/160C	65	40	80	50	576	10	8	132	160	261	120	122	100	70	120	240	190	65	14	274
BNMS 40/160B	65	40	80	50	590	10	8	132	160	270	120	122	100	70	120	240	190	65	14	274
BNMS 40/160A	65	40	80	50	617	10	8	132	160	306	120	122	100	70	120	240	190	65	14	274
BNMS 40/200D	65	40	100	50	637	12	8	160	180	334	141	141	100	70	120	265	212	65	14	274
BNMS 40/200C	65	40	100	50	637	12	8	160	180	334	141	141	100	70	120	265	212	65	14	274
BNMS 40/200D-S	65	40	100	50	666	12	8	160	180	320	141	141	100	70	250	265	212	130	14	407
BNMS 40/200C-S	65	40	100	50	666	12	8	160	180	320	141	141	100	70	250	265	212	130	14	407
BNMS 40/200B	65	40	100	50	666	12	8	160	180	320	141	141	100	70	250	265	212	130	14	407
BNMS 40/200AR	65	40	100	50	666	12	8	160	180	320	141	141	100	70	250	265	212	130	14	407
BNMS 40/200B-S	65	40	100	50	783	12	8	160	180	352	141	141	100	70	250	265	212	130	14	407
BNMS 40/200AR-S	65	40	100	50	783	12	8	160	180	352	141	141	100	70	250	265	212	130	14	407
BNMS 40/200A	65	40	100	50	783	12	8	160	180	352	141	141	100	70	250	265	212	130	14	407
BNMS 50/125F	65	50	100	50	596	10	8	132	160	261	122	137	100	70	120	240	190	65	14	274
BNMS 50/125D	65	50	100	50	610	10	8	132	160	270	122	137	100	70	120	240	190	65	14	274
BNMS 50/125A	65	50	100	50	637	10	8	132	160	306	122	137	100	70	120	240	190	65	14	274
BNMS 50/125S	65	50	100	50	637	10	8	132	160	306	122	137	100	70	120	240	190	65	14	274
BNMS 50/160B	65	50	100	50	666	12	8	160	180	320	125	140	100	70	250	265	212	130	14	407
BNMS 50/160A	65	50	100	50	783	12	8	160	180	352	125	140	100	70	250	265	212	130	14	407
BNMS 65/125E	80	65	100	65	637	12	8	160	180	334	130	154	125	95	120	280	212	65	14	274
BNMS 65/125C	80	65	100	65	666	12	8	160	180	320	130	154	125	95	250	280	212	130	14	407
BNMS 65/125A	80	65	100	65	783	12	8	160	180	352	130	154	125	95	250	280	212	130	14	407
BNMS 65/160D	80	65	100	65	783	12	8	160	200	352	140	161	125	95	250	280	212	130	14	407
BNMS 80/160E	100	80	125	65	808	12	8	180	225	372	152	181	125	95	250	320	250	130	14	407

## Dimensions and weights with IE4 motor

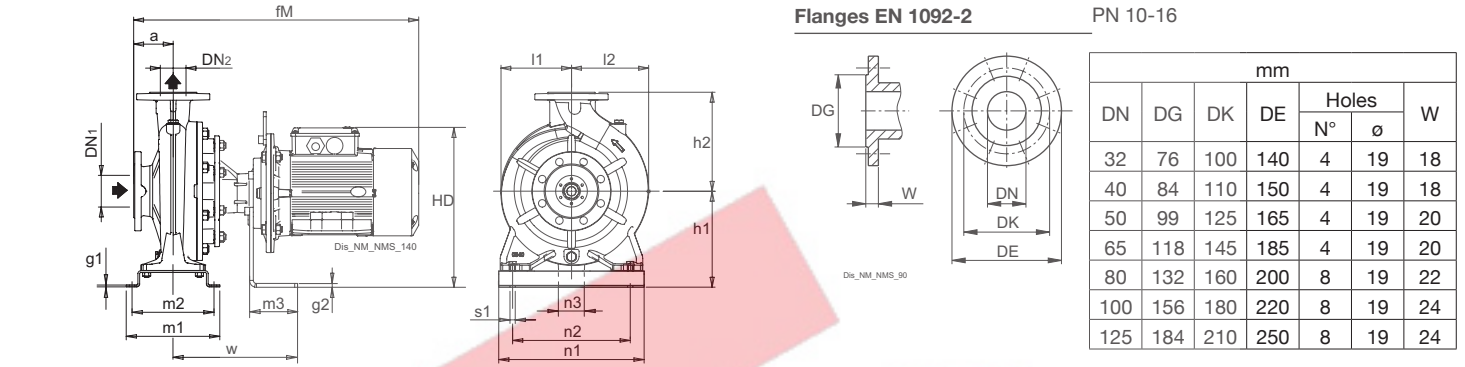

TYPE	DN1	DN2	mm																
			a	fM	g1	g2	h1	h2	HD	l1	l2	m1	m2	m3	n1	n2	n3	s1	w
BNMS 40/160A-S	65	40	80	646	4	8	180	160	340	120	122	190	190	250	250	190	130	14	407
BNMS 50/125S-S	65	50	100	666	4	8	180	160	340	122	137	190	190	250	250	190	130	14	407

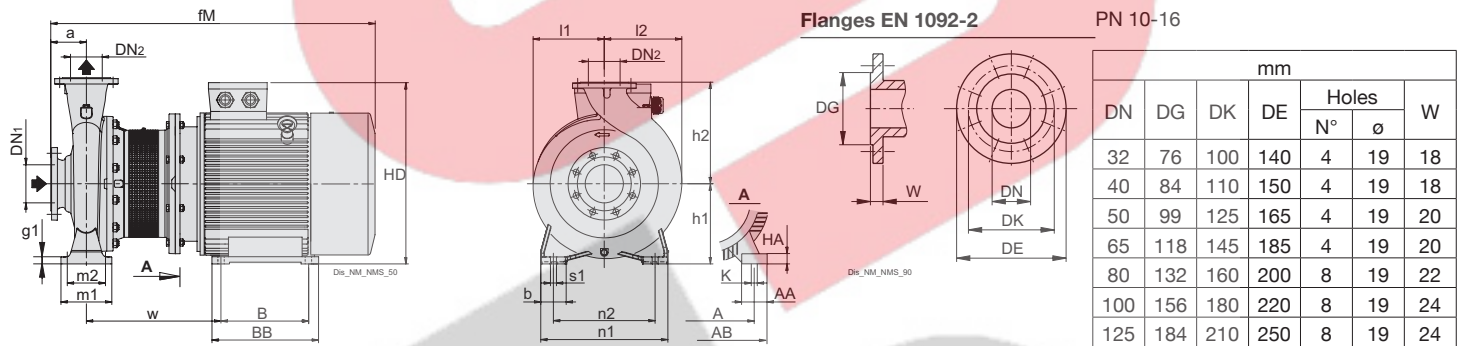

TYPE	DN1	DN2	mm																					
			a	A	AA	AB	b	B	BB	fM	g1	h1	h2	HA	HD	K	l1	l2	m1	m2	n1	n2	s1	w
BNMS 65/200A	80	65	100	279	70	350	65	241	315	915	12	180	225	22	450	15	159	179	125	95	320	250	14	394
BNMS 65/250B/B	80	65	100	318	70	388	80	305	370	1001	15	200	250	25	500	19	178	195	160	120	360	280	18	406
BNMS 65/250A/B	80	65	100	318	70	388	80	305	370	1001	15	200	250	25	500	19	178	195	160	120	360	280	18	406
BNMS 80/200B/B	100	80	125	279	70	350	65	241	315	940	15	180	250	22	450	15	170	194	125	95	345	280	14	394
BNMS 80/250D/A	100	80	125	318	70	388	80	305	370	1026	20	200	280	25	500	19	191	211	160	120	400	315	18	406
BNMS 80/250C/A	100	80	125	318	70	388	80	305	370	1026	20	200	280	25	500	19	191	211	160	120	400	315	18	406
BNMS 100/200C/A	125	100	125	318	70	388	80	305	370	1026	15	200	280	25	500	19	179	211	160	120	360	280	18	406
BNMS 100/200B/A	125	100	125	318	70	388	80	305	370	1026	15	200	280	25	500	19	179	211	160	120	360	280	18	406

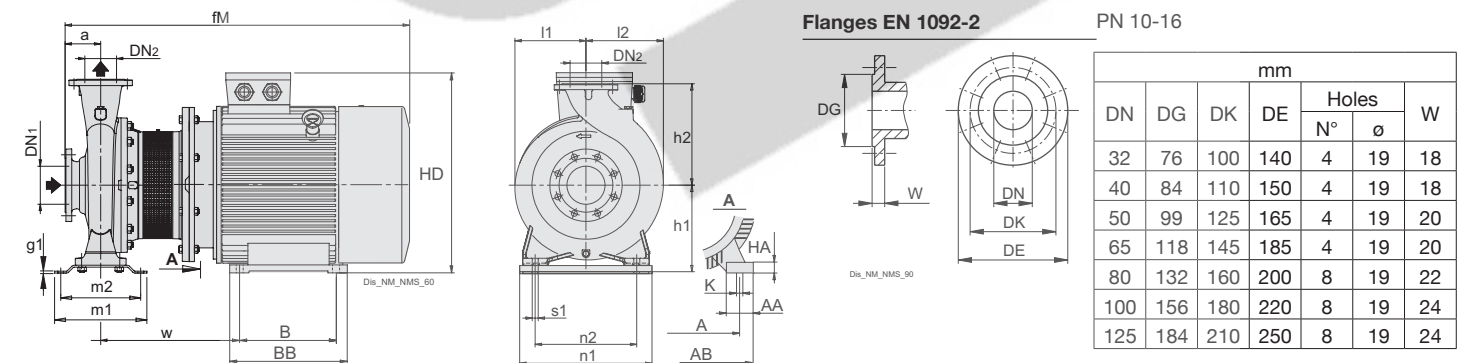

TYPE	DN1	DN2	mm																				
			a	A	AA	AB	B	BB	fM	g1	h1	h2	HA	HD	K	l1	l2	m1	m2	n1	n2	s1	w
BNMS 80/200A/B	100	80	125	318	70	388	305	370	1026	6	200	250	25	500	19	170	194	227	191	350	280	14	406
BNMS 80/250B/A	100	80	125	356	75	431	311	395	1125	6	225	280	28	548	19	191	211	298	258	410	315	18	445
BNMS 100/200A/A	125	100	125	356	75	431	311	395	1125	6	225	280	28	548	19	179	211	298	258	410	315	18	445
BNMS 100/250A/A	125	100	140	457	85	545	368	490	1264	6	280	280	35	669	24	205	233	260	220	410	315	18	516

## Dimensions and weights with IE4 motor

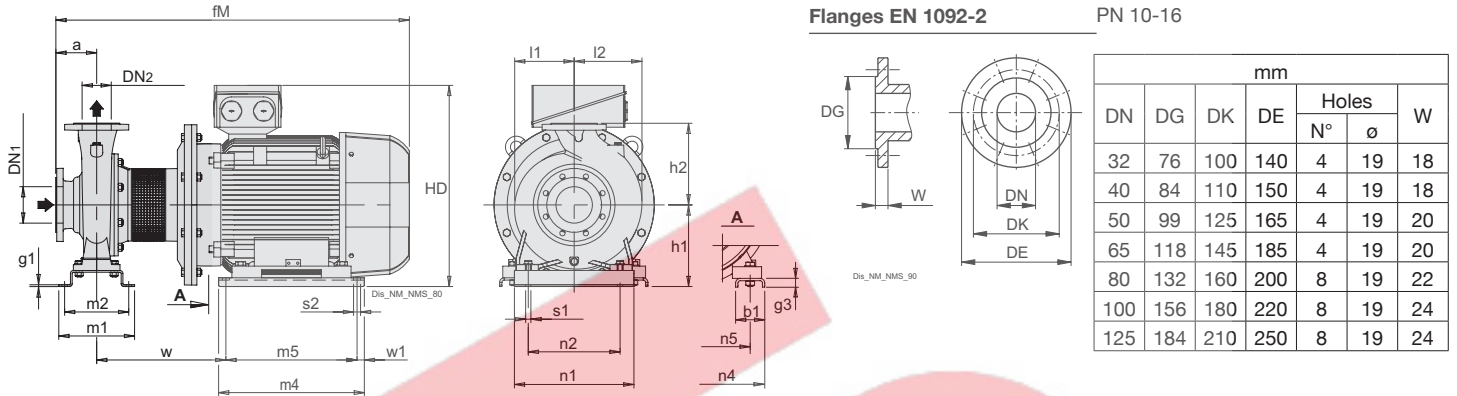

TYPE	DN1	DN2	mm																					
			a	b1	fM	g1	g3	h1	h2	HD	l1	l2	m1	m2	m4	m5	n1	n2	n4	n5	s1	s2	w	w1
BNMS 50/200B	65	50	100	80	829	4	20	180	200	433	142	152	245	212	394	354	290	215	334	254	14	15	314	20
BNMS 50/200A	65	50	100	80	829	4	20	180	200	433	142	152	245	212	394	354	290	215	334	254	14	15	314	20
BNMS 50/200S	65	50	100	80	829	4	20	180	200	433	142	152	245	212	394	354	290	215	334	254	14	15	314	20
BNMS 65/160C	80	65	100	80	829	4	20	180	200	433	140	161	245	212	394	354	290	215	334	254	14	15	314	20
BNMS 65/160B	80	65	100	80	829	4	20	180	200	433	140	161	245	212	394	354	290	215	334	254	14	15	314	20
BNMS 65/160AR	80	65	100	80	829	4	20	180	200	433	140	161	245	212	394	354	290	215	334	254	14	15	314	20
BNMS 65/160A	80	65	100	80	829	4	20	180	200	433	140	161	245	212	394	354	290	215	334	254	14	15	314	20
BNMS 80/250A/A	100	80	125	100	1187	6	30	280	280	642	191	211	260	220	570	520	410	315	506	406	18	24	408	25
BNMS 100/250B/A	125	100	140	100	1202	6	30	280	280	642	205	233	260	220	570	520	410	315	506	406	18	24	408	25

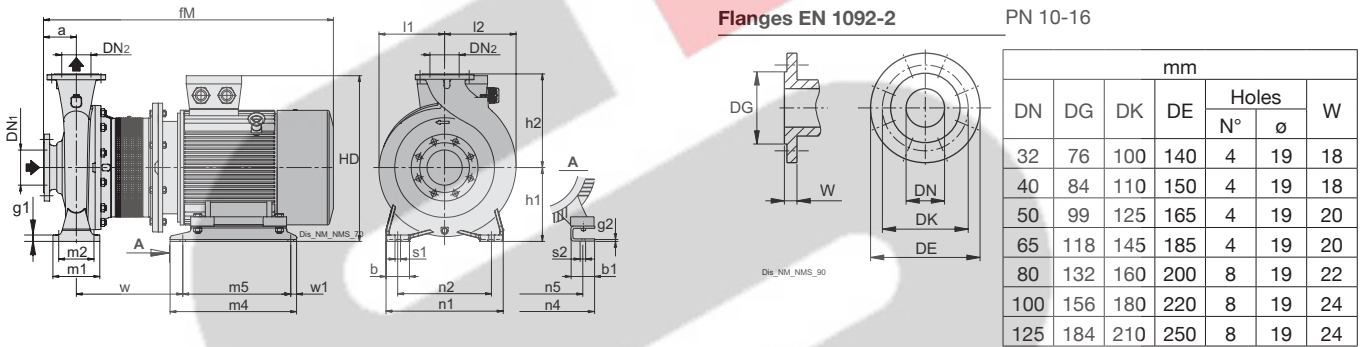

TYPE	DN1	DN2	mm																						
			a	b	b1	fM	g1	g3	h1	h2	HD	l1	l2	m1	m2	m4	m5	n1	n2	n4	n5	s1	s2	w	w1
BNMS 40/250C	65	40	100	65	80	829	15	20	180	225	433	177	177	125	95	394	354	320	250	334	254	14	15	314	20
BNMS 40/250B	65	40	100	65	80	829	15	20	180	225	433	177	177	125	95	394	354	320	250	334	254	14	15	314	20
BNMS 40/250A	65	40	100	65	80	829	15	20	180	225	433	177	177	125	95	394	354	320	250	334	254	14	15	314	20
BNMS 50/250C	65	50	100	65	80	829	15	20	180	225	433	177	177	125	95	394	354	320	250	334	254	14	15	314	20
BNMS 50/250B	65	50	100	65	80	829	15	20	180	225	433	177	177	125	95	394	354	320	250	334	254	14	15	314	20
BNMS 50/250A	65	50	100	65	80	873	15	20	180	225	433	177	177	125	95	394	354	320	250	334	254	14	15	314	20
BNMS 65/200C	80	65	100	65	80	829	12	20	180	225	433	159	179	125	95	394	354	320	250	334	254	14	15	314	20
BNMS 65/200B	80	65	100	65	80	873	12	20	180	225	433	159	179	125	95	394	354	320	250	334	254	14	15	314	20
BNMS 65/250C	80	65	100	80	70	915	15	20	200	250	470	178	195	160	120	440	400	360	280	349	279	18	15	333	20
BNMS 80/160D	100	80	125	65	80	854	12	20	180	225	433	152	181	125	95	394	354	320	250	334	254	14	15	314	20
BNMS 80/160C	100	80	125	65	80	854	12	20	180	225	433	152	181	125	95	394	354	320	250	334	254	14	15	314	20
BNMS 80/160B	100	80	125	65	80	854	12	20	180	225	433	152	181	125	95	394	354	320	250	334	254	14	15	314	20
BNMS 80/160A	100	80	125	65	80	898	12	20	180	225	433	152	181	125	95	394	354	320	250	334	254	14	15	314	20
BNMS 80/250E	100	80	125	80	70	940	20	20	200	280	470	191	211	160	120	440	400	315	349	279	18	15	333	20	
BNMS 100/200E	125	100	125	80	60	923	15	40	200	280	453	179	211	160	120	394	354	360	280	314	254	18	15	339	20
BNMS 100/200D/A	125	100	125	80	70	940	15	20	200	280	470	179	211	160	120	440	400	360	280	349	279	18	15	333	20

# NM4, NMS4



## Dimensions and weights

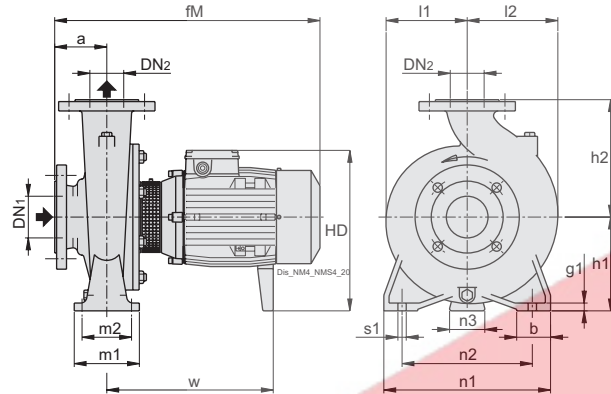

Flanges EN 1092-2

PN 10-16

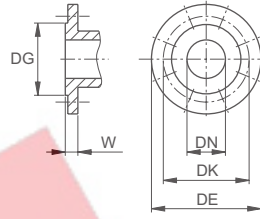

DN	DG	DK	DE	Holes		W
				N°	ø	
32	76	100	140	4	19	18
40	84	110	150	4	19	18
50	99	125	165	4	19	20
65	118	145	185	4	19	20
80	132	160	200	8	19	22
100	156	180	220	8	19	24
125	184	210	250	8	19	24

TYPE	DN1	DN2	mm																kg Weight
			a	b	fM	g1	h1	h2	HD	l1	l2	m1	m2	n1	n2	n3	s1	w	
NM4 32/20B/A	50	32	80	50	413	12	160	180	290	140	140	100	70	240	190	40	14	257	36.2
NM4 32/20A/B	50	32	80	50	453	12	160	180	290	140	140	100	70	240	190	40	14	297	41
NM4 32/16B/A	50	32	80	50	413	12	132	160	262	119	119	100	70	240	190	35	14	255	29.8
NM4 32/16A/A	50	32	80	50	413	12	132	160	262	119	119	100	70	240	190	35	14	255	29.7
NM4 40/25C/C	65	40	100	65	499	15	180	225	320	177	177	125	95	320	250	41	14	299	66.7
NM4 40/25B/C	65	40	100	65	559	15	180	225	347	177	177	125	95	320	250	37	14	337	79
NM4 40/25A/B	65	40	100	65	559	15	180	225	347	177	177	125	95	320	250	37	14	337	78.7
NM4 40/20B/B	65	40	100	50	499	12	160	180	300	141	141	100	70	265	212	37	14	297	49.6
NM4 40/20A/B	65	40	100	50	499	12	160	180	300	141	141	100	70	265	212	37	14	297	49.6
NM4 40/16C/B	65	40	80	50	413	10	132	160	262	120	122	100	70	240	190	35	14	255	29.9
NM4 40/16B/B	65	40	80	50	413	10	132	160	262	120	122	100	70	240	190	35	14	255	31.6
NM4 40/16A/C	65	40	80	50	453	10	132	160	262	120	122	100	70	240	190	35	14	295	38.2
NM4 50/16B/C	65	50	100	50	499	12	160	180	300	125	140	100	70	265	212	37	14	297	42.5
NM4 50/16A/C	65	50	100	50	499	12	160	180	300	125	140	100	70	265	212	37	14	297	42.5
NM4 50/20C/C	65	50	100	50	509	14	160	200	300	142	152	100	70	265	212	37	14	307	53.1
NM4 50/20B/C	65	50	100	50	509	14	160	200	300	142	152	100	70	265	212	37	14	307	56.4
NM4 50/20A/C	65	50	100	50	559	14	160	200	327	142	152	100	70	265	212	34	14	335	66.2
NM4 50/25D/B	65	50	100	65	559	15	180	225	347	177	177	125	95	320	250	37	14	337	79.8
NM4 50/25C/C	65	50	100	65	559	15	180	225	347	177	177	125	95	320	250	37	14	337	80.5
NM4 50/25B/B	65	50	100	65	559	15	180	225	347	177	177	125	95	320	250	37	14	337	81
NM4 50/25A/B	65	50	100	65	559	15	180	225	347	177	177	125	95	320	250	37	14	337	88.4
NM4 65/16C/C	80	65	100	65	499	12	160	200	300	140	161	125	95	280	212	37	14	297	48.7
NM4 65/16B/C	80	65	100	65	499	12	160	200	300	140	161	125	95	280	212	37	14	297	49.3
NM4 65/16A/C	80	65	100	65	499	12	160	200	300	140	161	125	95	280	212	37	14	297	52.4
NM4 65/16S/A	80	65	100	65	559	12	160	200	327	140	161	125	95	280	212	34	14	335	63.4
NM4 65/20B/C	80	65	100	65	559	12	180	225	347	159	179	125	95	320	250	37	14	337	69.6
NM4 65/20A/B	80	65	100	65	559	12	180	225	347	159	179	125	95	320	250	37	14	337	70.3
NM4 65/25B/B	80	65	100	80	574	15	200	250	367	178	195	160	120	360	280	41	18	354	98.1
NM4 65/25A/C	80	65	100	80	644	15	200	250	390	178	195	160	120	360	280	38	18	403	115.5
NM4 65/31C/B	80	65	125	80	669	20	225	280	415	223	223	160	120	400	315	43	18	406	155.5
NM4 65/31B/B	80	65	125	80	669	20	225	280	415	223	223	160	120	400	315	43	18	406	164.3
NM4 65/31A/B	80	65	125	80	744	20	225	280	415	223	223	160	120	400	315	43	18	481	168
NM4 80/16C/C	100	80	125	65	524	12	180	225	320	152	181	125	95	320	250	41	14	299	55.6
NM4 80/16B/C	100	80	125	65	524	12	180	225	320	152	181	125	95	320	250	41	14	299	59.6
NM4 80/16A/C	100	80	125	65	584	12	180	225	347	152	181	125	95	320	250	37	14	337	70.5
NM4 80/20C/C	100	80	125	65	594	15	180	250	347	170	194	125	95	345	280	37	14	347	77.4
NM4 80/20B/B	100	80	125	65	594	15	180	250	347	170	194	125	95	345	280	37	14	347	77.3
NM4 80/20A/B	100	80	125	65	594	15	180	250	347	170	194	125	95	345	280	37	14	347	85.5
NM4 80/25C/A	100	80	125	80	599	20	200	280	367	191	211	160	120	400	315	41	18	354	103.9
NM4 80/25B/B	100	80	125	80	669	20	200	280	390	191	211	160	120	400	315	38	18	403	120
NM4 80/25A/B	100	80	125	80	669	20	200	280	390	191	211	160	120	400	315	38	18	403	130.6
NM4 80/31C/B	100	80	125	80	744	17	250	315	440	222	234	160	120	400	315	47	18	483	171.1
NM4 100/20C/A	125	100	125	80	594	15	200	280	367	179	211	160	120	360	280	41	18	349	85
NM4 100/20B/A	125	100	125	80	594	15	200	280	367	179	211	160	120	360	280	41	18	349	92.9
NM4 100/20A/C	125	100	125	80	669	15	200	280	390	179	211	160	120	360	280	38	18	403	109
NM4 100/25B/B	125	100	140	80	684	20	225	280	415	205	233	160	120	400	315	43	18	406	141.4
NM4 100/25A/B	125	100	140	80	759	20	225	280	415	205	233	160	120	400	315	43	18	481	152.9
NM4 125/25E/B	150	125	140	80	684	20	250	355	440	236	268	160	120	400	315	47	18	408	149.5
NM4 125/25D/B	150	125	140	80	684	20	250	355	440	236	268	160	120	400	315	47	18	408	159.8
NM4 125/25C/B	150	125	140	80	759	20	250	355	440	236	268	160	120	400	315	47	18	483	171.2

# NM4, NMS4



## Dimensions and weights

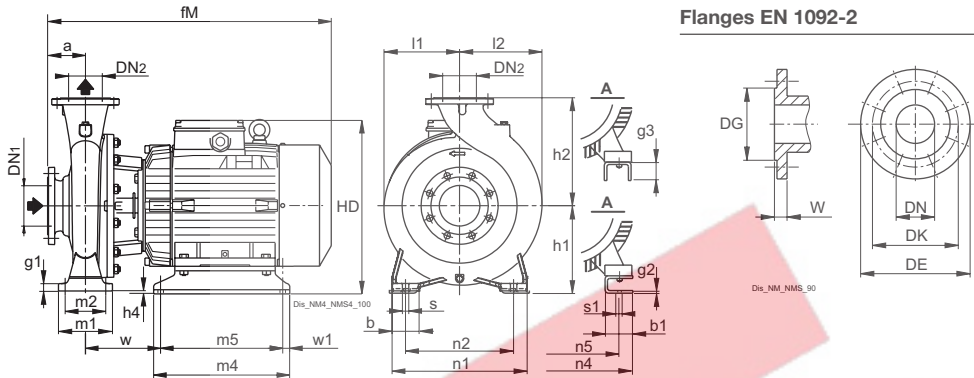

Flanges EN 1092-2

PN 10-16

DN	DG	DK	DE	Holes		W
				N°	ø	
32	76	100	140	4	19	18
40	84	110	150	4	19	18
50	99	125	165	4	19	20
65	118	145	185	4	19	20
80	132	160	200	8	19	22
100	156	180	220	8	19	24
125	184	210	250	8	19	24

TYPE	DN1	DN2	mm																							kg Weight	
			a	b	b1	fM	g1	g2	h1	h2	h4	HD	l1	l2	m1	m2	m4	m5	n1	n2	n4	n5	s1	s2	w		w1
NM4 80/31B	100	80	125	80	74	790	20	6	250	315	10	458	222	234	160	120	435	395	400	315	314	254	18	14	147	20	212
NM4 80/31A	100	80	125	80	74	790	20	6	250	315	10	458	222	234	160	120	435	395	400	315	314	254	18	14	147	20	226
NM4 100/31C	125	100	140	80	74	805	20	6	250	315	10	458	229	251	160	120	435	395	400	315	314	254	18	14	147	20	221.1
NM4 100/31B	125	100	140	80	74	805	20	6	250	315	10	458	229	251	160	120	435	395	400	315	314	254	18	14	147	20	235.2
NM4 125/25B	150	125	140	80	74	805	20	6	250	355	10	458	236	268	160	120	435	395	400	315	314	254	18	14	147	20	210.5
NM4 125/25A	150	125	140	80	74	805	20	6	250	355	10	458	236	268	160	120	435	395	400	315	314	254	18	14	147	20	223.2

# NM4, NMS4



## Dimensions and weights with IE3 motor

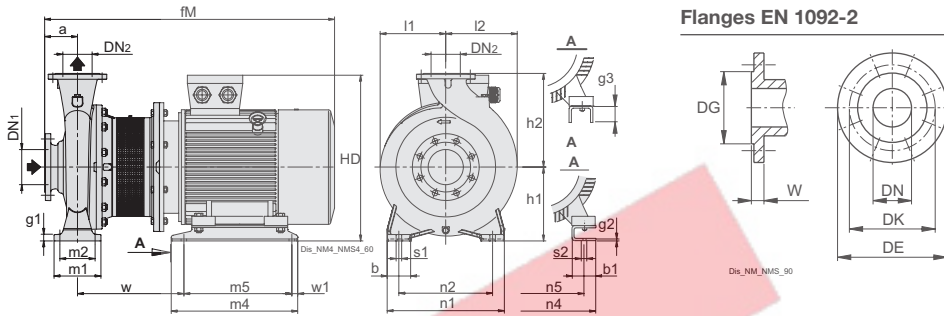

### Flanges EN 1092-2

### PN 10-16 (DN 200 PN 10)

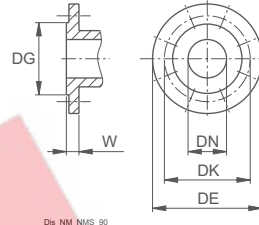

DN	DG	DK	DE	Holes		W
				N°	ø	
32	76	100	140	4	19	18
40	84	110	150	4	19	18
50	99	125	165	4	19	20
65	118	145	185	4	19	20
80	132	160	200	8	19	22
100	156	180	220	8	19	24
125	184	210	250	8	19	24
150	211	240	285	8	23	26
200	266	295	340	8*	23	30
250	319	355	405	12	28	26

TYPE	DN1	DN2	mm																								kg
			a	b	b1	fM	g1	g2	g3	h1	h2	HD	l1	l2	m1	m2	m4	m5	n1	n2	n4	n5	s1	s2	w	w1	
NMS4 65/315A	80	65	125	80	85	885	20	-	65	225	280	475	223	223	160	120	394	354	400	315	339	254	18	14	343	20	-
NMS4 80/315S	100	80	125	80	70	992	20	6	-	250	315	520	222	234	160	120	432	382	400	315	349	279	18	15	312	25	-
NMS4 80/315A	100	80	125	80	60	932	20	6	-	250	315	500	222	234	160	120	480	440	400	315	314	254	18	15	281	20	-
NMS4 80/315B/A	100	80	125	80	60	885	20	6	-	250	315	500	222	234	160	120	480	440	400	315	314	254	18	15	281	20	-
NMS4 80/315C	100	80	125	80	60	885	20	6	-	250	315	500	222	234	160	120	480	440	400	315	314	254	18	15	281	20	-
NMS4 80/400S	125	80	125	80	103	1123	15	-	55	280	355	610	267	269	160	120	540	490	435	355	459	356	18	19	379	25	-
NMS4 80/400A/B	125	80	125	80	83	1048	15	6	-	280	355	580	267	269	160	120	540	455	435	355	401	318	18	19	334	25	-
NMS4 80/400B/B	125	80	125	80	70	1030	15	6	-	280	355	566	267	269	160	120	520	435	435	355	349	279	18	15	318	25	-
NMS4 80/400C/B	125	80	125	80	70	997	15	6	-	280	355	550	267	269	160	120	520	435	435	355	349	279	18	15	318	25	-
NMS4 100/250A/A	125	100	140	80	85	888	20	-	65	225	280	475	205	233	160	120	394	354	400	315	339	254	18	14	331	20	-
NMS4 100/315A/A	125	100	140	80	70	1007	20	6	-	250	315	520	229	251	160	120	432	382	400	315	349	279	18	15	312	25	-
NMS4 100/315B/A	125	100	140	80	60	947	20	6	-	250	315	500	229	251	160	120	480	440	400	315	314	254	18	15	281	20	-
NMS4 100/315C/A	125	100	140	80	60	900	20	6	-	250	315	500	229	251	160	120	480	440	400	315	314	254	18	15	281	20	-
NMS4 100/400A/A	125	100	140	100	103	1143	27	-	55	280	355	610	268	280	200	150	540	490	500	400	459	356	22	19	384	25	504
NMS4 100/400B/A	125	100	140	100	83	1063	27	6	-	280	355	580	268	280	200	150	540	455	500	400	401	318	22	19	334	25	-
NMS4 100/400C/A	125	100	140	100	70	1045	27	6	-	280	355	566	268	280	200	150	520	435	500	400	349	279	22	15	318	25	-
NMS4 125/250A/A	150	125	140	80	60	935	20	6	-	250	355	500	236	268	160	120	480	440	400	315	314	254	18	15	269	20	-
NMS4 125/250B/A	150	125	140	80	60	888	20	6	-	250	355	500	236	268	160	120	480	440	400	315	314	254	18	15	269	20	-
NMS4 125/250C/A	150	125	140	80	60	888	20	6	-	250	355	500	236	268	160	120	480	440	400	315	314	254	18	15	269	20	-
NMS4 125/315A/A	150	125	140	100	83	1063	27	6	-	280	355	580	249	278	200	150	540	455	500	400	401	318	22	19	334	25	-
NMS4 125/315B/A	150	125	140	100	70	1045	27	6	-	280	355	566	249	278	200	150	520	435	500	400	349	279	22	15	318	25	-
NMS4 125/315C/A	150	125	140	100	70	1012	27	6	-	280	355	550	249	278	200	150	520	435	500	400	349	279	22	15	318	25	-
NMS4 125/400A/A	150	125	140	100	100	1360	27	-	65	315	400	677	280	305	200	150	580	530	500	400	506	406	22	24	427	25	-
NMS4 125/400B/A	150	125	140	100	103	1128	27	8	-	315	400	645	280	305	200	150	540	461	500	400	459	356	22	19	409	25	-
NMS4 125/400C/A	150	125	140	100	103	1143	27	8	-	315	400	645	280	305	200	150	540	461	500	400	459	356	22	19	409	25	-
NMS4 150/315S	200	150	160	100	103	1148	27	-	55	280	400	610	256	307	200	150	540	490	550	450	459	356	22	19	384	25	-
NMS4 150/315A/B	200	150	160	100	103	1163	27	-	55	280	400	610	256	307	200	150	540	490	550	450	459	356	22	19	384	25	-
NMS4 150/315B/B	200	150	160	100	83	1083	27	6	-	280	400	580	256	307	200	150	540	455	550	450	401	318	22	19	334	25	-
NMS4 150/315C/B	200	150	160	100	70	1065	27	6	-	280	400	566	256	307	200	150	520	435	550	450	349	279	22	15	318	25	-
NMS4 150/315D/B	200	150	160	100	70	1032	27	6	-	280	400	550	256	307	200	150	520	435	550	450	349	279	22	15	318	25	-
NMS4 150/400S	200	150	160	100	100	1470	27	-	35	315	450	700	295	328	200	150	690	600	550	450	557	457	22	24	449	45	-
NMS4 150/400A/B	200	150	160	100	100	1420	27	-	35	315	450	705	295	328	200	150	690	600	550	450	557	457	22	24	449	45	-
NMS4 150/400B/B	200	150	160	100	100	1380	27	-	65	315	450	677	295	328	200	150	580	530	550	450	506	406	22	24	427	25	-

# NM4, NMS4



## Dimensions and weights with IE4 motor

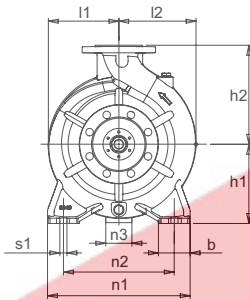
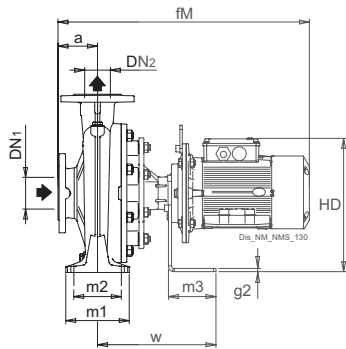

### Flanges EN 1092-2

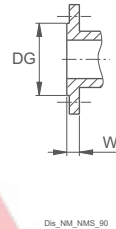

Dis. NM\_NMS\_90

### PN 10-16

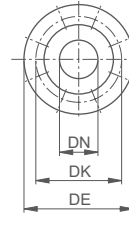

mm						
DN	DG	DK	DE	Holes		W
				N°	ø	
32	76	100	140	4	19	18
40	84	110	150	4	19	18
50	99	125	165	4	19	20
65	118	145	185	4	19	20
80	132	160	200	8	19	22
100	156	180	220	8	19	24
125	184	210	250	8	19	24

TYPE	mm																			
	DN1	DN2	a	b	fM	g1	g2	h1	h2	HD	l1	l2	m1	m2	m3	n1	n2	n3	s1	w
NMS4 32/200A	50	32	80	50	639	12	8	160	180	295	140	140	100	70	120	240	190	65	14	274
NMS4 40/160A	65	40	80	50	639	10	8	132	160	267	120	122	100	70	120	240	190	65	14	274
NMS4 40/200B	65	40	100	50	655	12	8	160	180	303	141	141	100	70	120	265	212	65	14	274
NMS4 40/200A	65	40	100	50	655	12	8	160	180	303	141	141	100	70	120	265	212	65	14	274
NMS4 40/250C	65	40	100	65	715	15	8	180	225	323	177	177	125	95	120	320	250	65	14	274
NMS4 40/250B	65	40	100	65	711	15	8	180	225	336	177	177	125	95	120	320	250	65	14	274
NMS4 40/250A	65	40	100	65	711	15	8	180	225	336	177	177	125	95	120	320	250	65	14	274
NMS4 50/160B	65	50	100	50	655	12	8	160	180	303	125	140	100	70	120	265	212	65	14	274
NMS4 50/160A	65	50	100	50	655	12	8	160	180	303	125	140	100	70	120	265	212	65	14	274
NMS4 50/200C	65	50	100	50	655	14	8	160	200	303	142	152	100	70	120	265	212	65	14	274
NMS4 50/200B	65	50	100	50	715	14	8	160	200	303	142	152	100	70	120	265	212	65	14	274
NMS4 50/200A	65	50	100	50	711	14	8	160	200	316	142	152	100	70	120	265	212	65	14	274
NMS4 50/250D	65	50	100	65	711	15	8	180	225	336	177	177	125	95	120	320	250	65	14	274
NMS4 50/250C	65	50	100	65	711	15	8	180	225	336	177	177	125	95	120	320	250	65	14	274
NMS4 50/250B	65	50	100	65	711	15	8	180	225	336	177	177	125	95	120	320	250	65	14	274
NMS4 50/250A	65	50	100	65	637	15	8	180	225	354	177	177	125	95	120	320	250	65	14	274
NMS4 65/160C	80	65	100	65	655	12	8	160	200	303	140	161	125	95	120	280	212	65	14	274
NMS4 65/160B	80	65	100	65	655	12	8	160	200	303	140	161	125	95	120	280	212	65	14	274
NMS4 65/160A	80	65	100	65	715	12	8	160	200	303	140	161	125	95	120	280	212	65	14	274
NMS4 65/160S	80	65	100	65	711	12	8	160	200	316	140	161	125	95	120	280	212	65	14	274
NMS4 65/200B	80	65	100	65	711	12	8	180	225	336	159	179	125	95	120	320	250	65	14	274
NMS4 65/200A	80	65	100	65	711	12	8	180	225	336	159	179	125	95	120	320	250	65	14	274
NMS4 65/250B	80	65	100	80	662	15	8	200	250	374	178	195	160	120	120	360	280	65	18	299
NMS4 80/160C	100	80	125	65	680	12	8	180	225	323	152	181	125	95	120	320	250	65	14	274
NMS4 80/160B	100	80	125	65	740	12	8	180	225	323	152	181	125	95	120	320	250	65	14	274
NMS4 80/160A	100	80	125	65	736	12	8	180	225	336	152	181	125	95	120	320	250	65	14	274
NMS4 80/200C	100	80	125	65	761	15	8	180	250	336	170	194	125	95	120	345	280	65	14	299
NMS4 80/200B	100	80	125	65	761	15	8	180	250	336	170	194	125	95	120	345	280	65	14	299
NMS4 80/200A	100	80	125	65	687	15	8	180	250	354	170	194	125	95	120	345	280	65	14	299
NMS4 80/250C	100	80	125	80	687	20	8	200	280	374	191	211	160	120	120	400	315	65	18	299
NMS4 100/200C	125	100	125	80	761	15	8	200	280	356	179	211	160	120	120	360	280	65	18	299
NMS4 100/200B	125	100	125	80	687	15	8	200	280	374	179	211	160	120	120	360	280	65	18	299

# NM4, NMS4



## Dimensions and weights with IE4 motor

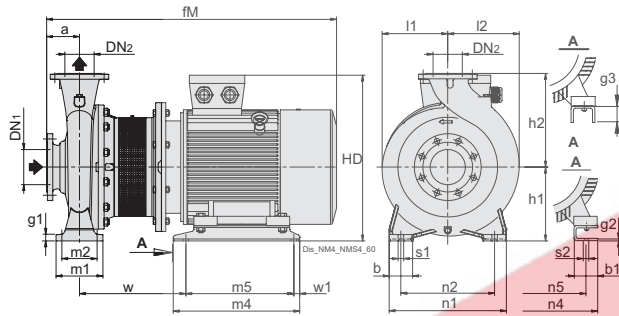

### Flanges EN 1092-2

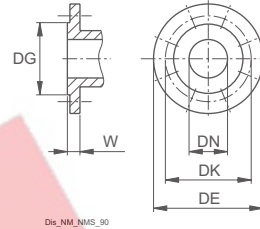

### PN 10-16 (DN 200 PN 10)

DN	DG	DK	DE	Holes		W
				N°	ø	
32	76	100	140	4	19	18
40	84	110	150	4	19	18
50	99	125	165	4	19	20
65	118	145	185	4	19	20
80	132	160	200	8	19	22
100	156	180	220	8	19	24
125	184	210	250	8	19	24
150	211	240	285	8	23	26
200	266	295	340	8*	23	30
250	319	355	405	12	28	26

TYPE			mm																							
	DN1	DN2	a	b	b1	fM	g1	g2	g3	h1	h2	HD	l1	l2	m1	m2	m4	m5	n1	n2	n4	n5	s1	s2	w	w1
NMS4 65/250A	80	65	100	80	69	708	15	6	-	200	250	392	178	195	160	120	298	258	360	280	285	216	18	12	281	20
NMS4 65/315B	80	65	125	80	69	770	20	6	-	225	280	419	223	223	160	120	298	258	400	315	285	216	18	12	300	20
NMS4 65/315C	80	65	125	80	69	733	20	6	-	225	280	417	223	223	160	120	298	258	400	315	285	216	18	12	281	20
NMS4 80/250A	100	80	125	80	69	770	20	6	-	200	280	394	191	211	160	120	298	258	400	315	285	216	18	12	300	20
NMS4 80/250B	100	80	125	80	69	733	20	6	-	200	280	392	191	211	160	120	298	258	400	315	285	216	18	12	281	20
NMS4 100/200A	125	100	125	80	69	733	15	6	-	200	280	392	179	211	160	120	298	258	360	280	285	216	18	12	281	20
NMS4 100/250B	125	100	140	80	69	785	20	6	-	225	280	419	205	233	160	120	298	258	400	315	285	216	18	12	300	20
NMS4 125/250D	150	125	140	80	69	785	20	6	-	250	355	419	236	268	160	120	298	258	400	315	285	216	18	12	300	20
NMS4 125/250E	150	125	140	80	69	748	20	6	-	250	355	417	236	268	160	120	298	258	400	315	285	216	18	12	281	20
NMS4 65/315A	80	65	125	80	85	883	20	-	65	225	280	478	223	223	160	120	394	354	400	315	339	254	18	14	343	20
NMS4 80/315S	100	80	125	80	70	952	20	6	-	250	315	520	222	234	160	120	432	382	400	315	349	279	18	15	312	25
NMS4 80/315A	100	80	125	80	60	927	20	6	-	250	315	503	222	234	160	120	480	440	400	315	314	254	18	15	281	20
NMS4 80/315B/A	100	80	125	80	60	883	20	6	-	250	315	503	222	234	160	120	480	440	400	315	314	254	18	15	281	20
NMS4 80/315C	100	80	125	80	60	883	20	6	-	250	315	503	222	234	160	120	480	440	400	315	314	254	18	15	281	20
NMS4 80/400S	125	80	125	80	103	1119	15	-	55	280	355	603	267	269	160	120	540	490	435	355	459	356	18	19	379	25
NMS4 80/400A/B	125	80	125	80	83	1043	15	6	-	280	355	580	267	269	160	120	540	455	435	355	401	318	18	19	334	25
NMS4 80/400B/B	125	80	125	80	70	1015	15	6	-	280	355	551	267	269	160	120	520	435	435	355	349	279	18	15	318	25
NMS4 80/400C/B	125	80	125	80	70	957	15	6	-	280	355	550	267	269	160	120	520	435	435	355	349	279	18	15	318	25
NMS4 100/250A/A	125	100	140	80	85	886	20	-	65	225	280	478	205	233	160	120	394	354	400	315	339	254	18	14	331	20
NMS4 100/315A/A	125	100	140	80	70	967	20	6	-	250	315	520	229	251	160	120	432	382	400	315	349	279	18	15	312	25
NMS4 100/315B/A	125	100	140	80	60	942	20	6	-	250	315	503	229	251	160	120	480	440	400	315	314	254	18	15	281	20
NMS4 100/315C/A	125	100	140	80	60	898	20	6	-	250	315	503	229	251	160	120	480	440	400	315	314	254	18	15	281	20
NMS4 100/400A/A	125	100	140	100	103	1139	27	-	55	280	355	603	268	280	200	150	540	490	500	400	459	356	22	19	384	25
NMS4 100/400B/A	125	100	140	100	83	1058	27	6	-	280	355	580	268	280	200	150	540	455	500	400	401	318	22	19	334	25
NMS4 100/400C/A	125	100	140	100	70	1030	27	6	-	280	355	551	268	280	200	150	520	435	500	400	349	279	22	15	318	25
NMS4 125/250A/A	150	125	140	80	60	930	20	6	-	250	355	503	236	268	160	120	480	440	400	315	314	254	18	15	269	20
NMS4 125/250B/A	150	125	140	80	60	886	20	6	-	250	355	503	236	268	160	120	480	440	400	315	314	254	18	15	269	20
NMS4 125/250C/A	150	125	140	80	60	886	20	6	-	250	355	503	236	268	160	120	480	440	400	315	314	254	18	15	269	20
NMS4 125/315A/A	150	125	140	100	83	1058	27	6	-	280	355	580	249	278	200	150	540	455	500	400	401	318	22	19	334	25
NMS4 125/315B/A	150	125	140	100	70	1030	27	6	-	280	355	551	249	278	200	150	520	435	500	400	349	279	22	15	318	25
NMS4 125/315C/A	150	125	140	100	70	972	27	6	-	280	355	550	249	278	200	150	520	435	500	400	349	279	22	15	318	25
NMS4 125/400A/A	150	125	140	100	100	1226	27	-	65	315	400	677	280	305	200	150	580	530	500	400	506	406	22	24	427	25
NMS4 125/400B/A	150	125	140	100	103	1194	27	8	-	315	400	638	280	305	200	150	540	461	500	400	459	356	22	19	409	25
NMS4 125/400C/A	150	125	140	100	103	1139	27	8	-	315	400	638	280	305	200	150	540	461	500	400	459	356	22	19	409	25
NMS4 150/315S	200	150	160	100	103	1214	27	-	55	280	400	603	256	307	200	150	540	490	550	450	459	356	22	19	384	25
NMS4 150/315A/B	200	150	160	100	103	1159	27	-	55	280	400	603	256	307	200	150	540	490	550	450	459	356	22	19	384	25
NMS4 150/315B/B	200	150	160	100	83	1078	27	6	-	280	400	580	256	307	200	150	540	455	550	450	401	318	22	19	334	25
NMS4 150/315C/B	200	150	160	100	70	1050	27	6	-	280	400	551	256	307	200	150	520	435	550	450	349	279	22	15	318	25
NMS4 150/315D/B	200	150	160	100	70	992	27	6	-	280	400	550	256	307	200	150	520	435	550	450	349	279	22	15	318	25
NMS4 150/400S	200	150	160	100	100	1438	27	-	35	315	450	704	295	328	200	150	690	600	550	450	557	457	22	24	449	45
NMS4 150/400A/B	200	150	160	100	100	1383	27	-	35	315	450	704	295	328	200	150	690	600	550	450	557	457	22	24	449	45
NMS4 150/400B/B	200	150	160	100	100	1246	27	-	65	315	450	677	295	328	200	150	580	530	550	450	506	406	22	24	427	25

# NM4, NMS4



## Dimensions and weights

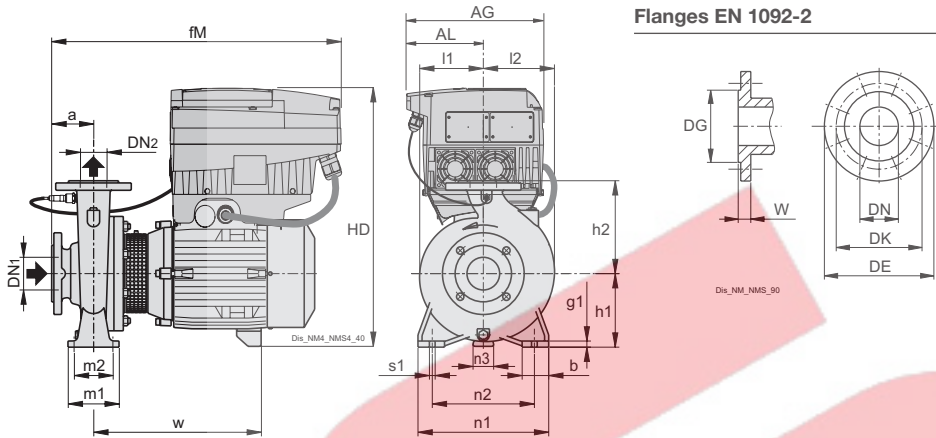

Flanges EN 1092-2

PN 10-16

DN	DG	DK	DE	Holes		W
				N°	ø	
32	76	100	140	4	19	18
40	84	110	150	4	19	18
50	99	125	165	4	19	20
65	118	145	185	4	19	20
80	132	160	200	8	19	22
100	156	180	220	8	19	24
125	184	210	250	8	19	24
150	211	240	285	8	23	26

TYPE	DN1	DN2	mm																		kg
			a	AG	AL	b	fM	g1	h1	h2	HD	l1	l2	m1	m2	n1	n2	n3	s1	w	
NM4 EI 32/16BE	50	32	80	190	105	50	440	12	132	160	260	120	120	100	70	240	190	47	14	255	-
NM4 EI 32/16AE	50	32	80	190	105	50	440	12	132	160	260	120	120	100	70	240	190	47	14	255	-
NM4 EI 32/20BE	50	32	80	190	105	50	440	12	160	180	288	140	140	100	70	240	190	62	14	255	-
NM4 EI 32/20A/B	50	32	80	190	105	50	453	12	160	180	445	140	140	100	70	240	190	40	14	297	47.9
NM4 EI 40/16C/B	65	40	80	190	105	50	413	10	132	160	417	120	122	100	70	240	190	35	14	255	-
NM4 EI 40/16B/B	65	40	80	190	105	50	413	10	132	160	417	120	122	100	70	240	190	35	14	255	-
NM4 EI 40/16A/C	65	40	80	190	105	50	453	10	132	160	417	120	122	100	70	240	190	35	14	295	43.8
NM4 EI 40/20B/B	65	40	100	190	105	50	499	12	160	180	455	141	141	100	70	265	212	37	14	297	55.5
NM4 EI 40/20A/B	65	40	100	190	105	50	499	12	160	180	455	141	141	100	70	265	212	37	14	297	-
NM4 EI 40/25C/C	65	40	100	190	105	65	499	15	180	225	475	177	177	125	95	320	250	41	14	299	-
NM4 EI 40/25B/C	65	40	100	210	118	65	559	15	180	225	504	177	177	125	95	320	250	37	14	337	-
NM4 EI 40/25A/B	65	40	100	210	118	65	559	15	180	225	504	177	177	125	95	320	250	37	14	337	-
NM4 EI 50/16B/C	65	50	100	190	105	50	499	12	160	180	455	125	140	100	70	265	212	37	14	297	-
NM4 EI 50/16A/C	65	50	100	190	105	50	499	12	160	180	455	125	140	100	70	265	212	37	14	297	52.4
NM4 EI 50/20C/C	65	50	100	190	105	50	509	14	160	200	455	142	152	100	70	265	212	37	14	307	59
NM4 EI 50/20B/C	65	50	100	190	105	50	509	14	160	200	455	142	152	100	70	265	212	37	14	307	-
NM4 EI 50/20A/C	65	50	100	210	118	50	559	14	160	200	484	142	152	100	70	265	212	34	14	335	-
NM4 EI 50/25D/B	65	50	100	210	118	65	559	15	180	225	504	177	177	125	95	320	250	37	14	337	-
NM4 EI 50/25C/C	65	50	100	210	118	65	559	15	180	225	504	177	177	125	95	320	250	37	14	337	-
NM4 EI 50/25B/B	65	50	100	210	118	65	559	15	180	225	504	177	177	125	95	320	250	37	14	337	-
NM4 EI 50/25A/B	65	50	100	210	118	65	559	15	180	225	504	177	177	125	95	320	250	37	14	337	-
NM4 EI 65/16C/C	80	65	100	190	105	65	499	12	160	200	455	140	161	125	95	280	212	37	14	297	54.6
NM4 EI 65/16B/C	80	65	100	190	105	65	499	12	160	200	455	140	161	125	95	280	212	37	14	297	-
NM4 EI 65/16A/C	80	65	100	190	105	65	499	12	160	200	455	140	161	125	95	280	212	37	14	297	57.9
NM4 EI 65/16S/A	80	65	100	210	118	65	559	12	160	200	484	140	161	125	95	280	212	34	14	335	-
NM4 EI 65/20B/C	80	65	100	210	118	65	559	12	180	225	504	159	179	125	95	320	250	37	14	337	-
NM4 EI 65/20A/B	80	65	100	210	118	65	559	12	180	225	504	159	179	125	95	320	250	37	14	337	-
NM4 EI 65/25B/B	80	65	100	210	118	80	574	15	200	250	524	178	195	160	120	360	280	41	18	354	-
NM4 EI 65/25A/B	80	65	100	281	154	80	644	15	200	250	589	178	195	160	120	360	280	38	18	403	-
NM4 EI 65/31C/B	80	65	125	281	154	80	669	20	225	280	614	223	223	160	120	400	315	43	18	406	-
NM4 EI 65/31B/B	80	65	125	281	154	80	669	20	225	280	614	223	223	160	120	400	315	43	18	406	-
NM4 EI 65/31A/B	80	65	125	281	154	80	744	20	225	280	614	223	223	160	120	400	315	43	18	481	-
NM4 EI 80/16C/C	100	80	125	190	105	65	524	12	180	225	475	152	181	125	95	320	250	41	14	299	-
NM4 EI 80/16B/C	100	80	125	190	105	65	524	12	180	225	475	152	181	125	95	320	250	41	14	299	65
NM4 EI 80/16A/C	100	80	125	210	118	65	584	12	180	225	504	152	181	125	95	320	250	37	14	337	-
NM4 EI 80/20C/C	100	80	125	210	118	65	594	15	180	250	504	170	194	125	95	345	280	37	14	347	-
NM4 EI 80/20B/B	100	80	125	210	118	65	594	15	180	250	504	170	194	125	95	345	280	37	14	347	86.5
NM4 EI 80/20A/B	100	80	125	210	118	65	594	15	180	250	504	170	194	125	95	345	280	37	14	347	-
NM4 EI 80/25C/A	100	80	125	210	118	80	599	20	200	280	524	191	211	160	120	400	315	41	18	354	111.5
NM4 EI 80/25B/B	100	80	125	281	154	80	669	20	200	280	589	191	211	160	120	400	315	38	18	403	136.6
NM4 EI 80/25A/B	100	80	125	281	154	80	669	20	200	280	589	191	211	160	120	400	315	38	18	403	145.5
NM4 EI 80/31C/B	100	80	125	281	154	80	744	20	250	315	639	222	234	160	120	400	315	47	18	483	-
NM4 EI 100/20C/A	125	100	125	210	118	80	594	15	200	280	524	179	211	160	120	360	280	41	18	349	-
NM4 EI 100/20B/A	125	100	125	210	118	80	594	15	200	280	524	179	211	160	120	360	280	41	18	349	-
NM4 EI 100/20A/C	125	100	125	281	154	80	669	15	200	280	589	179	211	160	120	360	280	38	18	403	-
NM4 EI 100/25B/B	125	100	140	281	154	80	684	20	225	280	614	205	233	160	120	400	315	43	18	406	-
NM4 EI 100/25A/B	125	100	140	281	154	80	759	20	225	280	614	205	233	160	120	400	315	43	18	481	166.3
NM4 EI 125/25E/B	150	125	140	281	154	80	684	20	250	355	639	236	268	160	120	400	315	47	18	408	-
NM4 EI 125/25D/B	150	125	140	281	154	80	684	20	250	355	639	236	268	160	120	400	315	47	18	408	-
NM4 EI 125/25C/B	150	125	140	281	154	80	759	20	250	355	639	236	268	160	120	400	315	47	18	483	-

# NM4, NMS4



## Dimensions and weights

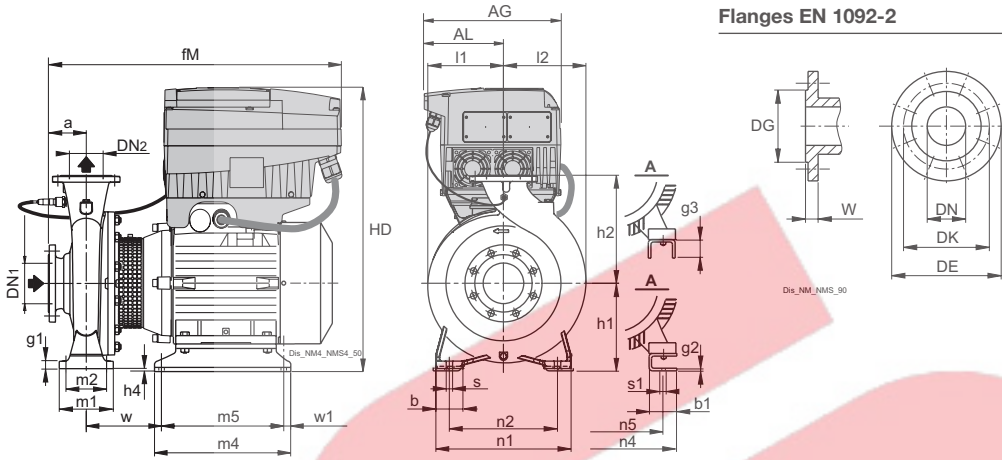

Flanges EN 1092-2

PN 10-16

mm						
DN	DG	DK	DE	Holes		W
				N°	ø	
32	76	100	140	4	19	18
40	84	110	150	4	19	18
50	99	125	165	4	19	20
65	118	145	185	4	19	20
80	132	160	200	8	19	22
100	156	180	220	8	19	24
125	184	210	250	8	19	24
150	211	240	285	8	23	26

TYPE	mm																									
	DN1	DN2	a	AG	AL	b	b1	fM	g2	h1	h2	h4	HD	l1	l2	m1	m2	m4	m5	n1	n2	n5	s1	s2	w	w1
NM4 EI 80/31B	100	80	125	281	153.5	80	74	790	6	250	315	10	657	222	234	160	120	435	395	400	315	254	18	14	323	20
NM4 EI 80/31A	100	80	125	350	190	80	74	790	6	250	315	10	738	222	234	160	120	435	395	400	315	254	18	14	323	20
NM4 EI 100/31C	125	100	140	281	153.5	80	74	805	6	250	315	10	657	229	251	160	120	435	395	400	315	254	18	14	323	20
NM4 EI 100/31B	125	100	140	350	190	80	74	805	6	250	315	10	738	229	251	160	120	435	395	400	315	254	18	14	323	20
NM4 EI 125/25B	150	125	140	281	153.5	80	74	805	6	250	355	10	657	236	268	160	120	435	395	400	315	254	18	14	323	20
NM4 EI 125/25A	150	125	140	350	190	80	74	805	6	250	355	10	738	236	268	160	120	435	395	400	315	254	18	14	323	20

# NM4, NMS4



## Dimensions and weights

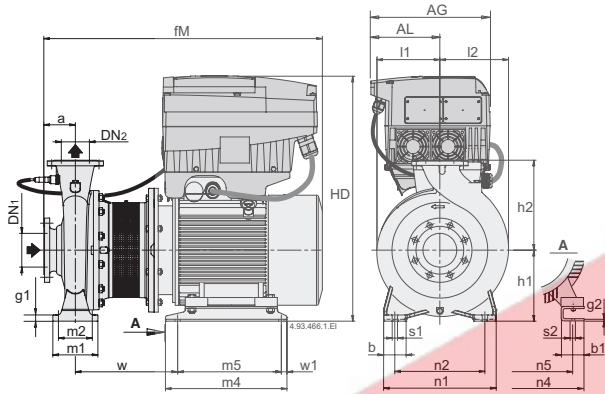

### Flanges EN 1092-2

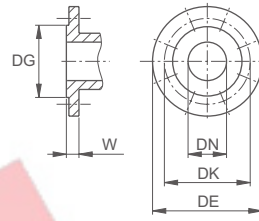

### PN 10-16 (DN 200 PN 10)

DN	DG	DK	DE	Holes		W
				N°	ø	
32	76	100	140	4	19	18
40	84	110	150	4	19	18
50	99	125	165	4	19	20
65	118	145	185	4	19	20
80	132	160	200	8	19	22
100	156	180	220	8	19	24
125	184	210	250	8	19	24
150	211	240	285	8	23	26
200	266	295	340	8*	23	30
250	319	355	405	12	28	26

TYPE	DN1	DN2	mm																								kg Weight	
			a	AG	AL	b	b1	fM	g1	g2	h1	h2	HD	l1	l2	m1	m2	m4	m5	n1	n2	n4	n5	s1	s2	w		w1
NMS4 EI 80/315S	100	80	125	350	190	80	70	999	17	6	250	315	789	222	234	160	120	432	382	400	315	338	279	18	15	312	25	-
NMS4 EI 80/400C/B	100	80	125	350	190	80	70	1004	15	6	280	355	819	267	269	160	120	520	435	435	355	338	279	18	15	318	25	-
NMS4 EI 80/400B/B	100	80	125	350	190	80	70	1004	15	6	280	355	819	267	269	160	120	520	435	435	355	338	279	18	15	318	25	-
NMS4 EI 80/400A/B	100	80	125	350	190	80	83	1051	15	6	280	355	863	267	269	160	120	540	455	435	355	388	318	18	19	334	25	-
NMS4 EI 100/315A/A	125	100	140	350	190	80	70	1014	20	6	250	315	789	229	251	160	120	432	382	400	315	338	279	18	15	312	25	-
NMS4 EI 100/400C/A	125	100	140	350	190	100	70	1019	27	6	280	355	819	268	280	200	150	520	435	500	400	338	279	22	15	318	25	-
NMS4 EI 100/400B/A	125	100	140	350	190	100	83	1066	27	6	280	355	863	268	280	200	150	540	455	500	400	388	318	22	19	334	25	445
NMS4 EI 125/315C/A	150	125	140	350	190	100	70	1019	27	6	280	355	819	249	278	200	150	520	435	500	400	338	279	22	15	318	25	-
NMS4 EI 125/315B/A	150	125	140	350	190	100	70	1019	27	6	280	355	819	249	278	200	150	520	435	500	400	338	279	22	15	318	25	-
NMS4 EI 125/315A/A	150	125	140	350	190	100	83	1066	27	6	280	355	863	249	278	200	150	540	455	500	400	388	318	22	19	334	25	-
NMS4 EI 150/315B/B	200	150	160	350	190	100	83	1086	27	6	280	400	863	104	119	200	150	540	455	550	450	388	318	22	19	334	25	-

# NM4, NMS4



## Dimensions and weights

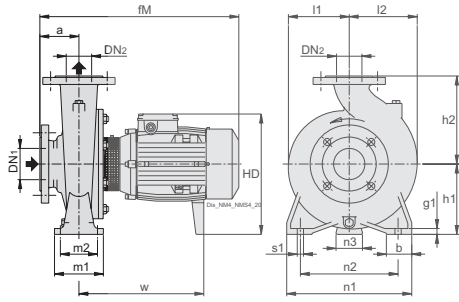

Flanges EN 1092-2

PN 10-16

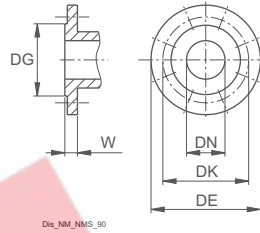

DN	DG	DK	DE	Holes		W
				N°	ø	
32	76	100	140	4	19	18
40	84	110	150	4	19	18
50	99	125	165	4	19	20
65	118	145	185	4	19	20
80	132	160	200	8	19	22
100	156	180	220	8	19	24
125	184	210	250	8	19	24

TYPE	DN1	DN2	mm																kg Weight
			a	b	fM	g1	h1	h2	HD	l1	l2	m1	m2	n1	n2	n3	s1	w	
BNM4 32/16B/A	50	32	80	50	413	12	132	160	261	119	119	100	70	240	190	35	14	255	33.4
BNM4 32/16A/A	50	32	80	50	413	12	132	160	261	119	119	100	70	240	190	35	14	255	33.5
BNM4 32/20B/A	50	32	80	50	413	12	160	180	289	140	140	100	70	240	190	40	14	257	39.5
BNM4 32/20A/B	50	32	80	50	453	12	160	180	299	140	140	100	70	240	190	40	14	297	45.2
BNM4 40/16C/A	65	40	80	50	413	10	132	160	261	120	122	100	70	240	190	35	14	255	35
BNM4 40/16B/A	65	40	80	50	413	10	132	160	261	120	122	100	70	240	190	35	14	255	36.8
BNM4 40/16A/B	65	40	80	50	453	10	132	160	261	120	122	100	70	240	190	35	14	295	42.8
BNM4 40/20B/B	65	40	100	50	499	12	160	180	299	141	141	100	70	265	212	37	14	297	54.6
BNM4 40/20A/B	65	40	100	50	499	12	160	180	299	141	141	100	70	265	212	37	14	297	55.1
BNM4 50/16B/B	65	50	100	50	499	12	160	180	299	125	140	100	70	265	212	37	14	297	52.7
BNM4 50/16A/B	65	50	100	50	499	12	160	180	299	125	140	100	70	265	212	37	14	297	53
BNM4 50/20B/C	65	50	100	50	509	14	160	200	299	142	152	100	70	265	212	37	14	307	59.6
BNM4 50/20B/C	65	50	100	50	509	14	160	200	299	142	152	100	70	265	212	37	14	307	-
BNM4 50/20A/C	65	50	100	50	528	14	160	200	321	142	152	100	70	265	212	34	14	276	73.6
BNM4 65/16C/C	80	65	100	65	499	12	160	200	299	140	161	125	95	280	212	37	14	297	-
BNM4 65/16B/C	80	65	100	65	499	12	160	200	299	140	161	125	95	280	212	37	14	297	54.9
BNM4 65/16A/C	80	65	100	65	499	12	160	200	299	140	161	125	95	280	212	37	14	297	58.4
BNM4 65/16S/A	80	65	100	65	528	12	160	200	321	140	161	125	95	280	212	34	14	276	69.8
BNM4 65/20B/A	80	65	100	65	528	12	180	225	341	159	179	125	95	320	250	37	14	278	77.5
BNM4 65/20A/A	80	65	100	65	528	12	180	225	341	159	179	125	95	320	250	37	14	278	77.9
BNM4 65/25B/B	80	65	100	80	543	15	200	250	361	178	195	160	120	360	280	41	18	295	110.4
BNM4 65/25A/C	80	65	100	80	644	15	200	250	387	178	195	160	120	360	280	36	18	403	-
BNM4 65/31C/B	80	65	125	80	669	20	225	280	412	223	223	160	120	400	315	41	18	405	170.2
BNM4 65/31B/B	80	65	125	80	669	20	225	280	412	223	223	160	120	400	315	41	18	405	-
BNM4 65/31A/B	80	65	125	80	719	20	225	280	412	223	223	160	120	400	315	41	18	465	-
BNM4 80/20C/A	100	80	125	65	563	18	180	250	341	170	194	125	95	345	280	37	14	288	-
BNM4 80/20B/A	100	80	125	65	563	18	180	250	341	170	194	125	95	345	280	37	14	288	88
BNM4 80/20A/A	100	80	125	65	563	18	180	250	341	170	194	125	95	345	280	37	14	288	-
BNM4 80/25C/A	100	80	125	80	568	20	200	280	361	191	211	160	120	400	315	41	18	295	114.7
BNM4 80/31C/B	100	80	125	80	744	17	250	315	437	222	234	160	120	400	315	46	18	482	-
BNM4 100/20C/A	125	100	125	80	563	15	200	280	361	179	211	160	120	360	280	41	18	290	96.6
BNM4 100/20B/A	125	100	125	80	563	15	200	280	361	179	211	160	120	360	280	41	18	290	103
BNM4 100/20A/C	125	100	125	80	669	15	200	280	387	179	211	160	120	360	280	36	18	403	123

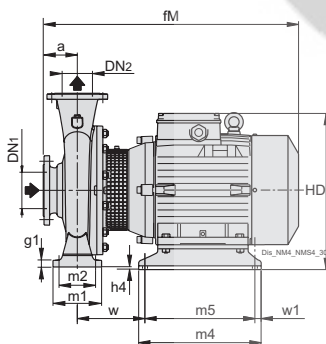

Flanges EN 1092-2

PN 10-16

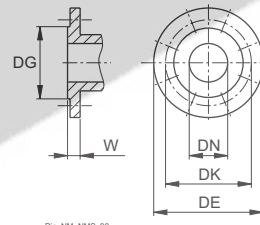
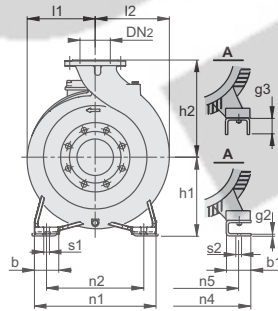

DN	DG	DK	DE	Holes		W
				N°	ø	
32	76	100	140	4	19	18
40	84	110	150	4	19	18
50	99	125	165	4	19	20
65	118	145	185	4	19	20
80	132	160	200	8	19	22
100	156	180	220	8	19	24
125	184	210	250	8	19	24

TYPE	DN1	DN2	mm																				kg Weight		
			a	b	b1	fM	g2	h1	h2	h4	HD	l1	l2	m1	m2	m4	m5	n1	n2	n5	s1	s2		w	w1
BNM4 4025/C/C	65	40	100	65	54	495	6	190	225	10	329	177	177	125	95	205	175	320	250	140	14	10	115	15	-
BNM4 4025/B/C	65	40	100	65	60	513	6	190	225	10	351	177	177	125	95	280	250	320	250	190	14	12	80	15	92.2
BNM4 4025/A/B	65	40	100	65	60	513	6	190	225	10	351	177	177	125	95	280	250	320	250	190	14	12	80	15	91.6
BNM4 5025/D/B	65	50	100	65	60	513	6	190	225	10	351	171	171	125	95	280	250	320	250	190	14	12	80	15	-
BNM4 5025/C/C	65	50	100	65	60	513	6	190	225	10	351	171	171	125	95	280	250	320	250	190	14	12	80	15	96.9
BNM4 5025/B/B	65	50	100	65	60	513	6	190	225	10	351	171	171	125	95	280	250	320	250	190	14	12	80	15	95.7
BNM4 5025/A/B	65	50	100	65	60	513	6	190	225	10	351	171	171	125	95	280	250	320	250	190	14	12	80	15	104

# NM4, NMS4



## Dimensions and weights with IE3 motor

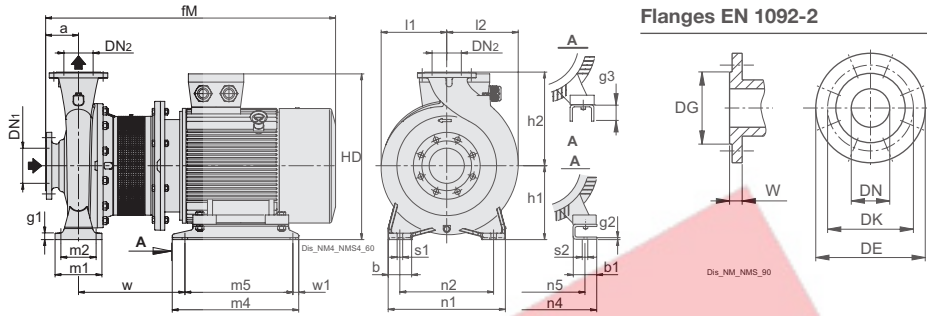

Flanges EN 1092-2

PN 10-16 (DN 200 PN 10)

mm						
DN	DG	DK	DE	Holes		W
				N°	ø	
32	76	100	140	4	19	18
40	84	110	150	4	19	18
50	99	125	165	4	19	20
65	118	145	185	4	19	20
80	132	160	200	8	19	22
100	156	180	220	8	19	24
125	184	210	250	8	19	24
150	211	240	285	8	23	26
200	266	295	340	8*	23	30
250	319	355	405	12	28	26

TYPE	mm																									
	DN1	DN2	a	b	b1	fM	g1	g2	g3	h1	h2	HD	l1	l2	m1	m2	m4	m5	n1	n2	n4	n5	s1	s2	w	w1
BNMS4 65/315A	80	65	125	80	85	885	20	-	65	225	280	475	223	223	160	120	394	354	400	315	339	254	18	14	343	20
BNMS4 80/315A	100	80	125	80	60	932	20	6	-	250	315	500	222	234	160	120	480	440	400	315	314	254	18	15	281	20
BNMS4 80/400A/B	125	80	125	80	83	1048	15	6	-	280	355	580	267	269	160	120	540	455	435	355	401	318	18	19	334	25
BNMS4 100/250A/A	125	100	140	80	85	888	20	-	65	225	280	475	205	233	160	120	394	354	400	315	339	254	18	14	331	20
BNMS4 100/315A/A	125	100	140	80	70	1007	20	6	-	250	315	520	229	251	160	120	432	382	400	315	349	279	18	15	312	25
BNMS4 100/400A/A	125	100	140	100	103	1143	27	-	55	280	355	610	268	280	200	150	540	490	500	400	459	356	22	19	384	25
BNMS4 125/250A/A	150	125	140	80	60	935	20	6	-	250	355	500	236	268	160	120	480	440	400	315	314	254	18	15	269	20
BNMS4 125/315A/A	150	125	140	100	83	1063	27	6	-	280	355	580	249	278	200	150	540	455	500	400	401	318	22	19	334	25
BNMS4 125/400A/A	150	125	140	100	100	1360	27	-	65	315	400	677	280	305	200	150	580	530	500	400	506	406	22	24	427	25
BNMS4 150/315A/B	200	150	160	100	103	1163	27	-	55	280	400	610	256	307	200	150	540	490	500	450	459	356	22	19	384	25
BNMS4 150/400A/B	200	150	160	100	100	1420	27	-	35	315	450	705	295	328	200	150	690	600	550	450	557	457	22	24	449	45
BNMS4 80/315B/A	100	80	125	80	60	885	20	6	-	250	315	500	222	234	160	120	480	440	400	315	314	254	18	15	281	20
BNMS4 80/400B/A	125	80	125	80	70	1030	15	6	-	280	355	566	267	269	160	120	520	435	435	355	349	279	18	15	318	25
BNMS4 100/315B/A	125	100	140	80	60	947	20	6	-	250	315	500	229	251	160	120	480	440	400	315	314	254	18	15	281	20
BNMS4 100/400B/A	125	100	140	100	83	1063	27	6	-	280	355	580	268	280	200	150	540	455	500	400	401	318	22	19	334	25
BNMS4 125/250B/A	150	125	140	80	60	888	20	6	-	250	355	500	236	268	160	120	480	440	400	315	314	254	18	15	269	20
BNMS4 125/315B/A	150	125	140	100	70	1045	27	6	-	280	355	566	249	278	200	150	520	435	500	400	349	279	22	15	318	25
BNMS4 125/400B/A	150	125	140	100	103	1128	27	8	-	315	400	645	280	305	200	150	540	461	500	400	459	356	22	19	409	25
BNMS4 150/315B/B	200	150	160	100	83	1083	27	6	-	280	400	580	256	307	200	150	540	455	550	450	401	318	22	19	334	25
BNMS4 150/400B/B	200	150	160	100	100	1380	27	-	65	315	450	677	295	328	200	150	580	530	550	450	506	406	22	24	427	25
BNMS4 80/315C	100	80	125	80	60	885	20	6	-	250	315	500	222	234	160	120	480	440	400	315	314	254	18	15	281	20
BNMS4 80/400C/B	125	80	125	80	70	997	15	6	-	280	355	550	267	269	160	120	520	435	435	355	349	279	18	15	318	25
BNMS4 100/315C/A	125	100	140	80	60	900	20	6	-	250	315	500	229	251	160	120	480	440	400	315	314	254	18	15	281	20
BNMS4 100/400C/A	125	100	140	100	70	1045	27	6	-	280	355	566	268	280	200	150	520	435	500	400	349	279	22	15	318	25
BNMS4 125/250C/A	150	125	140	80	60	888	20	6	-	250	355	500	236	268	160	120	480	440	400	315	314	254	18	15	269	20
BNMS4 125/315C/A	150	125	140	100	70	1012	27	6	-	280	355	550	249	278	200	150	520	435	500	400	349	279	22	15	318	25
BNMS4 125/400C/A	150	125	140	100	103	1143	27	8	-	315	400	645	280	305	200	150	540	461	500	400	459	356	22	19	409	25
BNMS4 150/315C/B	200	150	160	100	70	1065	27	6	-	280	400	566	256	307	200	150	520	435	550	450	349	279	22	15	318	25
BNMS4 150/315D/B	200	150	160	100	70	1032	27	6	-	280	400	550	256	307	200	150	520	435	550	450	349	279	22	15	318	25
BNMS4 80/315S	100	80	125	80	70	992	20	6	-	250	315	520	222	234	160	120	432	382	400	315	349	279	18	15	312	25
BNMS4 80/400S	125	80	125	80	103	1123	15	-	55	280	355	610	267	269	160	120	540	490	435	355	459	356	18	19	379	25
BNMS4 150/315S	200	150	160	100	103	1148	27	-	55	280	400	610	256	307	200	150	540	490	550	450	459	356	22	19	384	25
BNMS4 150/400S	200	150	160	100	100	1470	27	-	35	315	450	700	295	328	200	150	690	600	550	450	557	457	22	24	449	45

# NM4, NMS4



## Dimensions and weights with IE4 motor

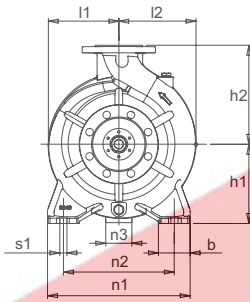
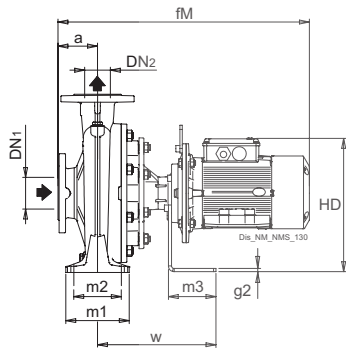

### Flanges EN 1092-2

### PN 10-16

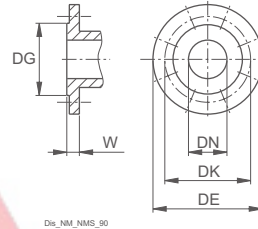

DN	DG	DK	DE	Holes		W
				N°	ø	
				32	76	
40	84	110	150	4	19	18
50	99	125	165	4	19	20
65	118	145	185	4	19	20
80	132	160	200	8	19	22
100	156	180	220	8	19	24
125	184	210	250	8	19	24

TYPE	mm																			
	DN1	DN2	a	b	fM	g1	g2	h1	h2	HD	l1	l2	m1	m2	m3	n1	n2	n3	s1	w
BNMS4 32/200A	50	32	80	50	639	12	8	160	180	295	140	140	100	70	120	240	190	65	14	274
BNMS4 40/160A	65	40	80	50	639	10	8	132	160	267	120	122	100	70	120	240	190	65	14	274
BNMS4 40/200B	65	40	100	50	655	12	8	160	180	303	141	141	100	70	120	265	212	65	14	274
BNMS4 40/200A	65	40	100	50	655	12	8	160	180	303	141	141	100	70	120	265	212	65	14	274
BNMS4 40/250C	65	40	100	65	715	15	8	180	225	323	177	177	125	95	120	320	250	65	14	274
BNMS4 40/250B	65	40	100	65	711	15	8	180	225	336	177	177	125	95	120	320	250	65	14	274
BNMS4 40/250A	65	40	100	65	711	15	8	180	225	336	177	177	125	95	120	320	250	65	14	274
BNMS4 50/160B	65	50	100	50	655	12	8	160	180	303	125	140	100	70	120	265	212	65	14	274
BNMS4 50/160A	65	50	100	50	655	12	8	160	180	303	125	140	100	70	120	265	212	65	14	274
BNMS4 50/200C	65	50	100	50	655	14	8	160	200	303	142	152	100	70	120	265	212	65	14	274
BNMS4 50/200B	65	50	100	50	715	14	8	160	200	303	142	152	100	70	120	265	212	65	14	274
BNMS4 50/200A	65	50	100	50	711	14	8	160	200	316	142	152	100	70	120	265	212	65	14	274
BNMS4 50/250D	65	50	100	65	711	15	8	180	225	336	177	177	125	95	120	320	250	65	14	274
BNMS4 50/250C	65	50	100	65	711	15	8	180	225	336	177	177	125	95	120	320	250	65	14	274
BNMS4 50/250B	65	50	100	65	711	15	8	180	225	336	177	177	125	95	120	320	250	65	14	274
BNMS4 50/250A	65	50	100	65	637	15	8	180	225	354	177	177	125	95	120	320	250	65	14	274
BNMS4 65/160C	80	65	100	65	655	12	8	160	200	303	140	161	125	95	120	280	212	65	14	274
BNMS4 65/160B	80	65	100	65	655	12	8	160	200	303	140	161	125	95	120	280	212	65	14	274
BNMS4 65/160A	80	65	100	65	715	12	8	160	200	303	140	161	125	95	120	280	212	65	14	274
BNMS4 65/200B	80	65	100	65	711	12	8	180	225	336	159	179	125	95	120	320	250	65	14	274
BNMS4 65/200A	80	65	100	65	711	12	8	180	225	336	159	179	125	95	120	320	250	65	14	274
BNMS4 65/250B	80	65	100	80	662	15	8	200	250	374	178	195	160	120	120	360	280	65	18	299
BNMS4 80/160C	100	80	125	65	680	12	8	180	225	323	152	181	125	95	120	320	250	65	14	274
BNMS4 80/160B	100	80	125	65	740	12	8	180	225	323	152	181	125	95	120	320	250	65	14	274
BNMS4 80/160A	100	80	125	65	736	12	8	180	225	336	152	181	125	95	120	320	250	65	14	274
BNMS4 80/200C	100	80	125	65	761	15	8	180	250	336	170	194	125	95	120	345	280	65	14	299
BNMS4 80/200B	100	80	125	65	761	15	8	180	250	336	170	194	125	95	120	345	280	65	14	299
BNMS4 80/200A	100	80	125	65	687	15	8	180	250	354	170	194	125	95	120	345	280	65	14	299
BNMS4 80/250C	100	80	125	80	687	20	8	200	280	374	191	211	160	120	120	400	315	65	18	299
BNMS4 100/200C	125	100	125	80	761	15	8	200	280	356	179	211	160	120	120	360	280	65	18	299
BNMS4 100/200B	125	100	125	80	687	15	8	200	280	374	179	211	160	120	120	360	280	65	18	299

# NM4, NMS4



## Dimensions and weights with IE4 motor

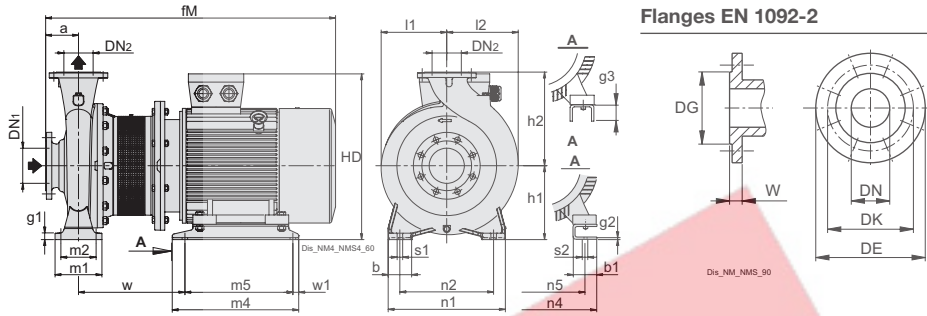

Flanges EN 1092-2

PN 10-16 (DN 200 PN 10)

DN	DG	DK	DE	Holes		W
				N°	ø	
32	76	100	140	4	19	18
40	84	110	150	4	19	18
50	99	125	165	4	19	20
65	118	145	185	4	19	20
80	132	160	200	8	19	22
100	156	180	220	8	19	24
125	184	210	250	8	19	24
150	211	240	285	8	23	26
200	266	295	340	8*	23	30
250	319	355	405	12	28	26

TYPE	mm																											
	DN1	DN2	a	b	b1	fM	g1	g2	g3	h1	h2	HD	l1	l2	m1	m2	m4	m5	n1	n2	n4	n5	s1	s2	w	w1		
BNMS4 65/250A	80	65	100	80	69	708	15	6	-	200	250	392	178	195	160	120	298	258	360	280	285	216	18	12	281	20		
BNMS4 65/315C	80	65	125	80	69	733	20	6	-	225	280	417	223	223	160	120	298	258	400	315	285	216	18	12	281	20		
BNMS4 65/315B	80	65	125	80	69	770	20	6	-	225	280	419	223	223	160	120	298	258	400	315	285	216	18	12	300	20		
BNMS4 65/315A	80	65	125	80	85	883	20	-	65	225	280	478	223	223	160	120	394	354	400	315	339	254	18	14	343	20		
BNMS4 80/250B	100	80	125	80	69	733	20	6	-	200	280	392	191	211	160	120	298	258	400	315	285	216	18	12	281	20		
BNMS4 80/250A	100	80	125	80	69	770	20	6	-	200	280	394	191	211	160	120	298	258	400	315	285	216	18	12	300	20		
BNMS4 80/315C	100	80	125	80	60	883	20	6	-	250	315	503	222	234	160	120	480	440	400	315	314	254	18	15	281	20		
BNMS4 80/315B/A	100	80	125	80	60	883	20	6	-	250	315	503	222	234	160	120	480	440	400	315	314	254	18	15	281	20		
BNMS4 80/315A	100	80	125	80	60	927	20	6	-	250	315	503	222	234	160	120	480	440	400	315	314	254	18	15	281	20		
BNMS4 80/315S	100	80	125	80	70	952	20	6	-	250	315	520	222	234	160	120	432	382	400	315	349	279	18	15	312	25		
BNMS4 80/400C/B	125	80	125	80	70	957	15	6	-	280	355	550	267	269	160	120	520	435	435	355	349	279	18	15	318	25		
BNMS4 80/400B/B	125	80	125	80	70	1015	15	6	-	280	355	551	267	269	160	120	520	435	435	355	349	279	18	15	318	25		
BNMS4 80/400A/B	125	80	125	80	83	1043	15	6	-	280	355	580	267	269	160	120	540	455	435	355	401	318	18	19	334	25		
BNMS4 80/400S	125	80	125	80	103	1119	15	-	55	280	355	603	267	269	160	120	540	490	435	355	459	356	18	19	379	25		
BNMS4 100/200A	125	100	125	80	69	733	15	6	-	200	280	392	179	211	160	120	298	258	360	280	285	216	18	12	281	20		
BNMS4 100/250B	125	100	140	80	69	785	20	6	-	225	280	419	205	233	160	120	298	258	400	315	285	216	18	12	300	20		
BNMS4 100/250A/A	125	100	140	80	85	886	20	-	65	225	280	478	205	233	160	120	394	354	400	315	339	254	18	14	331	20		
BNMS4 100/315C/A	125	100	140	80	60	898	20	6	-	250	315	503	229	251	160	120	480	440	400	315	314	254	18	15	281	20		
BNMS4 100/315B/A	125	100	140	80	60	942	20	6	-	250	315	503	229	251	160	120	480	440	400	315	314	254	18	15	281	20		
BNMS4 100/315A/A	125	100	140	80	70	967	20	6	-	250	315	520	229	251	160	120	432	382	400	315	349	279	18	15	312	25		
BNMS4 100/400C/A	125	100	140	100	70	1030	27	6	-	280	355	551	268	280	200	150	520	435	500	400	349	279	22	15	318	25		
BNMS4 100/400B/A	125	100	140	100	83	1058	27	6	-	280	355	580	268	280	200	150	540	455	500	400	401	318	22	19	334	25		
BNMS4 100/400A/A	125	100	140	100	103	1139	27	-	55	280	355	603	268	280	200	150	540	490	500	400	459	356	22	19	384	25		
BNMS4 125/250E	150	125	140	80	69	748	20	6	-	250	355	417	236	268	160	120	298	258	400	315	285	216	18	12	281	20		
BNMS4 125/250D	150	125	140	80	69	785	20	6	-	250	355	419	236	268	160	120	298	258	400	315	285	216	18	12	300	20		
BNMS4 125/250C/A	150	125	140	80	60	886	20	6	-	250	355	503	236	268	160	120	480	440	400	315	314	254	18	15	269	20		
BNMS4 125/250B/A	150	125	140	80	60	886	20	6	-	250	355	503	236	268	160	120	480	440	400	315	314	254	18	15	269	20		
BNMS4 125/250A/A	150	125	140	80	60	930	20	6	-	250	355	503	236	268	160	120	480	440	400	315	314	254	18	15	269	20		
BNMS4 125/315C/A	150	125	140	100	70	972	27	6	-	280	355	550	249	278	200	150	520	435	500	400	349	279	22	15	318	25		
BNMS4 125/315B/A	150	125	140	100	70	1030	27	6	-	280	355	551	249	278	200	150	520	435	500	400	349	279	22	15	318	25		
BNMS4 125/315A/A	150	125	140	100	83	1058	27	6	-	280	355	580	249	278	200	150	540	455	500	400	401	318	22	19	334	25		
BNMS4 125/400C/A	150	125	140	100	103	1139	27	8	-	315	400	638	280	305	200	150	540	461	500	400	459	356	22	19	409	25		
BNMS4 125/400B/A	150	125	140	100	103	1194	27	8	-	315	400	638	280	305	200	150	540	461	500	400	459	356	22	19	409	25		
BNMS4 125/400A/A	150	125	140	100	100	1226	27	-	65	315	400	677	280	305	200	150	580	530	500	400	506	406	22	24	427	25		
BNMS4 150/315D/B	200	150	160	100	70	992	27	6	-	280	400	550	256	307	200	150	520	435	550	450	349	279	22	15	318	25		
BNMS4 150/315C/B	200	150	160	100	70	1050	27	6	-	280	400	551	256	307	200	150	520	435	550	450	349	279	22	15	318	25		
BNMS4 150/315B/B	200	150	160	100	83	1078	27	6	-	280	400	580	256	307	200	150	540	455	550	450	401	318	22	19	334	25		
BNMS4 150/315A/B	200	150	160	100	103	1159	27	-	55	280	400	603	256	307	200	150	540	490	550	450	459	356	22	19	384	25		
BNMS4 150/315S	200	150	160	100	103	1214	27	-	55	280	400	603	256	307	200	150	540	490	550	450	459	356	22	19	384	25		
BNMS4 150/400B/B	200	150	160	100	100	1246	27	-	65	315	450	677	295	328	200	150	580	530	550	450	506	406	22	24	427	25		
BNMS4 150/400A/B	200	150	160	100	100	1383	27	-	35	315	450	704	295	328	200	150	690	600	550	450	557	457	22	24	449	45		
BNMS4 150/400S	200	150	160	100	100	1438	27	-	35	315	450	704	295	328	200	150	690	600	550	450	557	457	22	24	449	45		