

Automatic Burner Controls
IFS 110 IM





Automatic Burner Controls IFS 110 IM

- /// Flame control by means of flame rod or UV-detector
- /// Flame simulation check before starting and after switching the burner off
- /// Suitable for ignition and ionisation control with one electrode
- /// Modern technique using semiconductors
- /// High cycling frequency
- /// Remote reset
- /// External fault indication
- /// FM approved
- /// Kromschroder is a company certified to ISO 9001

Construction IFS 110 IM..

For the flame control by means of flame rod or Kromschroder UV-detector (see note on page 6). With ionisation control, a grounded mains is required.

Application

The automatic burner control unit IFS 110 IM is suitable for the ignition and control of gas burners in gas firing installations of all types.

This control is designed for high cycling frequency and long life, especially for industrial applications.

Multiburner control in conjunction with flame relay IFW 15 T (see leaflet T 12.6.1.1.10).

Examples of application

Operation with one electrode (Fig. 1)

The ignition and control of the burner with only one electrode is possible when using ignition transformers TZI or TGI. During the ignition, the high voltage coil of the ignition transformer is grounded via the burner control unit.

For the flame control, the electrode is switched to the flame amplifier of the burner control via the high voltage winding.



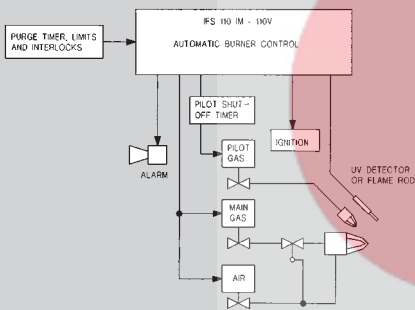

Block diagram for interrupted system

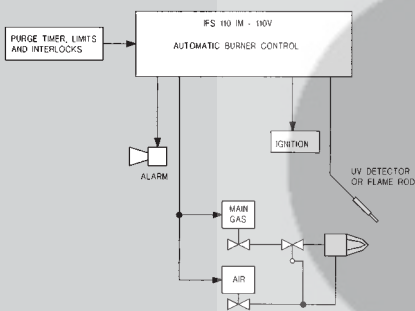

Block diagram for direct spark ignition



**Circuit diagram IFS 110 IM
for operation with one electrode
for spark ignition and ionization control
(interrupted pilot system is shown)**

-  Flame amplifier
-  Power supply
-  Ignition control circuit
-  Gas valve control circuit
-  Fault lockout reset

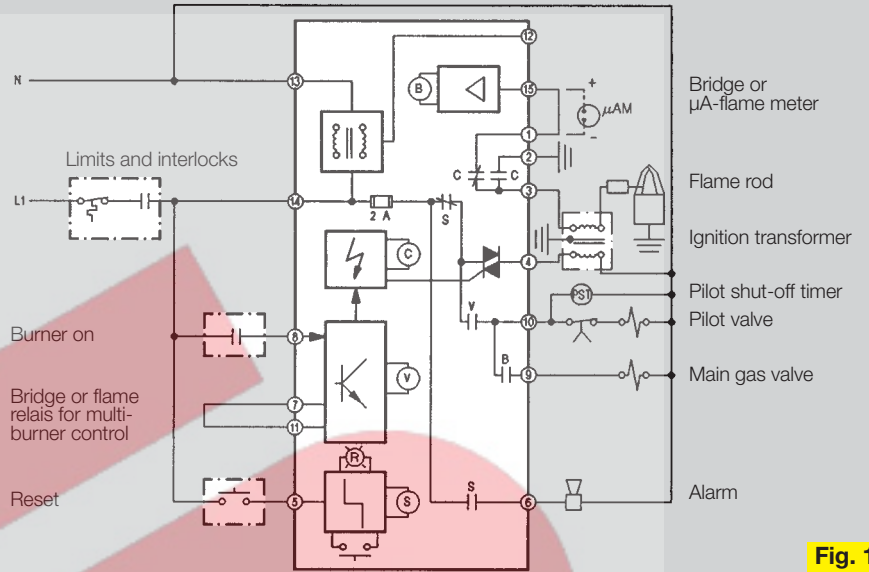

Fig. 1

**Circuit diagram IFS 110 IM
for direct spark ignition**

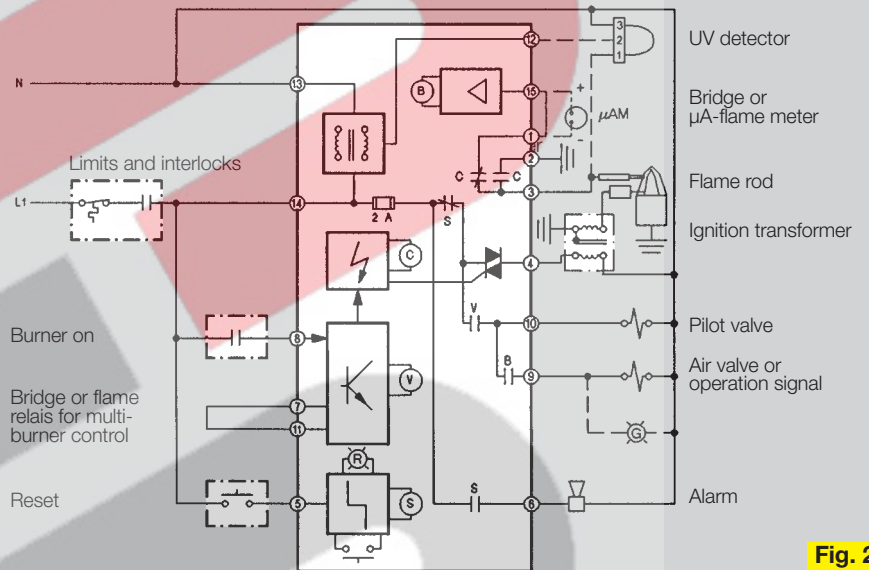

Fig. 2

**Circuit diagram IFS 110 IM
for interrupted pilot system**

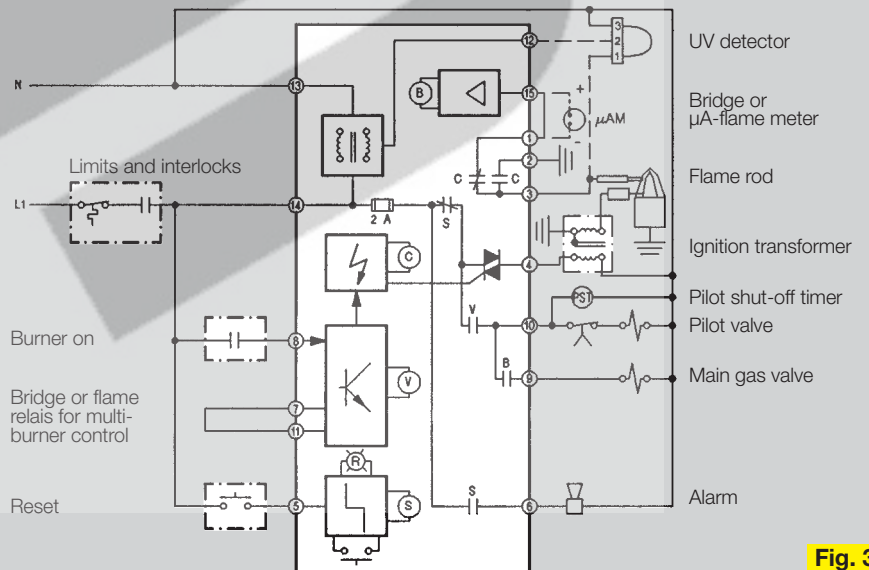
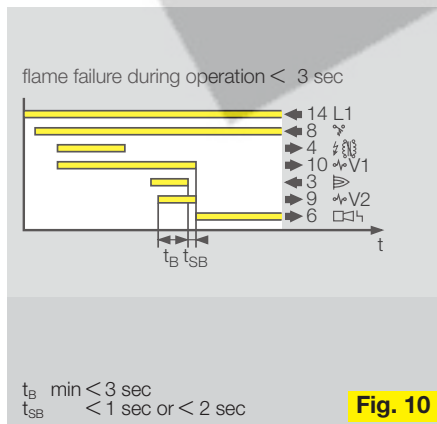
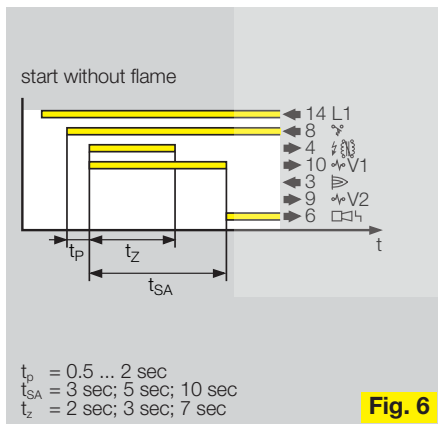
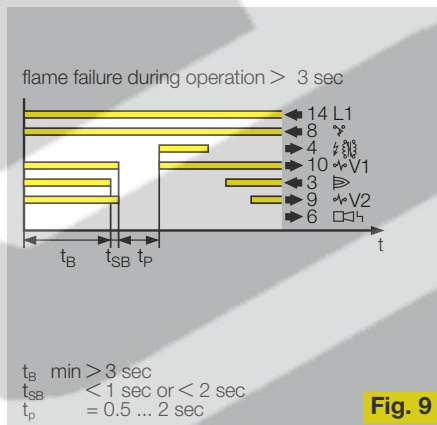
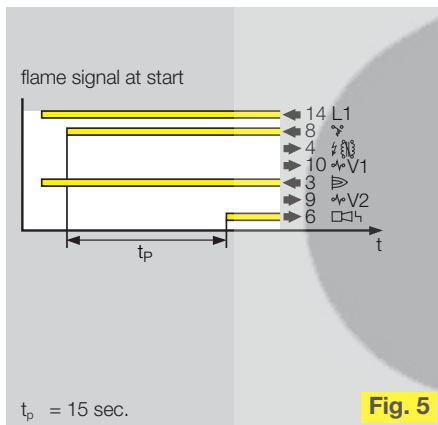
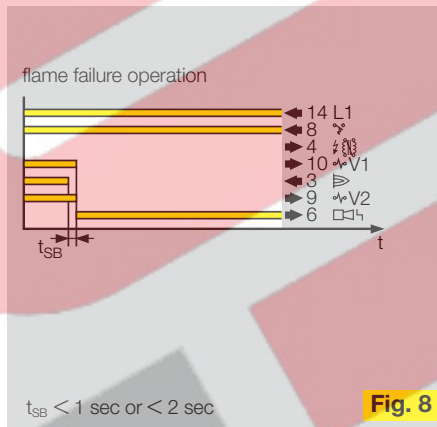
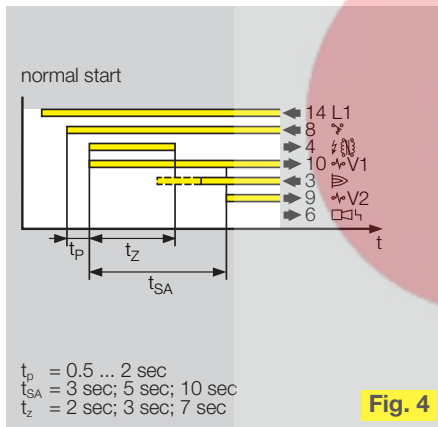
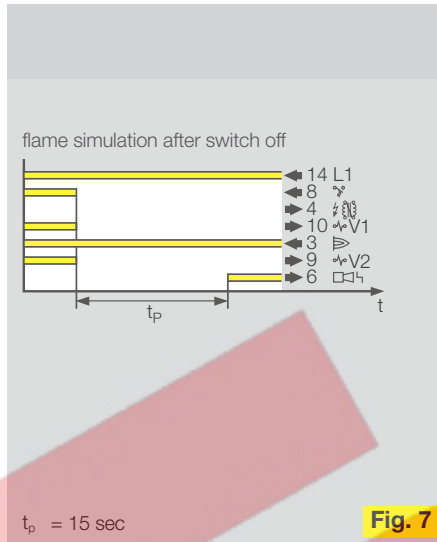
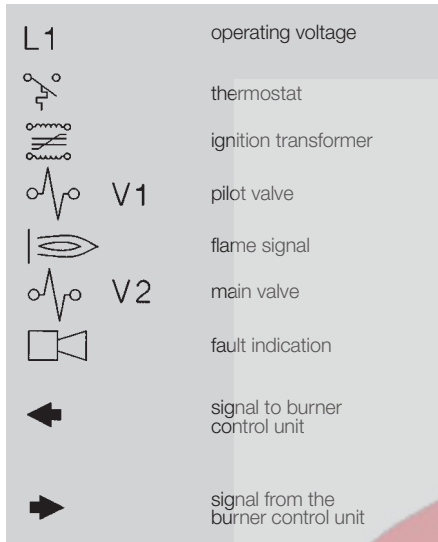

Fig. 3



Operation

The control checks for flame simulation and fail-safe during the testing time t_p . If a flame signal is not detected during the testing time and after the thermostat has called for heat, the burner is started: Voltage is applied to valve 1 and ignition transformer (Fig. 4). The testing time increases up to 15 sec, if flame simulation is detected. The control then goes to fault-lockout (Fig. 5).

Following the burner start, a flame signal must be measured within the trial for ignition period t_{SA} : After this time t_{SA} voltage is applied to valve V2 which then opens (Fig. 4). If a flame does not establish, the control goes to fault-lockout (Fig. 6).

During the burner operation, the control continuously checks for a flame signal. Behaviour with flame failure – see variations.

The burner control unit also checks for a flame signal after the burner has shutdown. If the flame does not extinguish within approx. 15 sec after the burner has been shut-down by the thermostat, the control will go fault-lockout (Fig. 7).

The fault-lockout is connected with an internal and external fault indication.

Reset following a fault-lockout by means of an internal or external push-button.

t_p = testing time (0.5 - 2 sec) with flame simulation up to max. 5 sec.

t_{SA} = trial for ignition period / safety time

t_z = ignition time

t_{SA}	3	5	10 sec
t_z	2	3	7 sec

Variations

2 variations are available; they differ in their behaviour with flame failure during operation.

For choosing the right burner control unit for your type of application, we would recommend to refer to the respective standards.

IFS 110 IM

Standard version.

Immediate lockout with flame failure (Fig. 8).

IFS 110 IM-W

With recycle on flame failure.

Upon failure of the flame signal, there is an automatic recycling on flame failure attempt (Fig. 9)

A further failure within 3 sec. will cause a fault-lockout (Fig. 10)

t_B = time of operation

t_{SB} = flame failure response time (< 1 sec or < 2 sec)

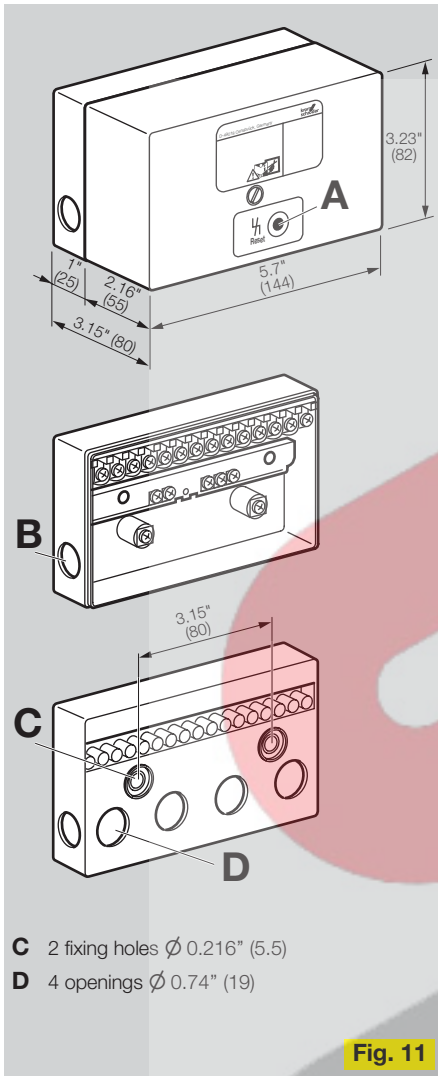

Construction

Housing of impact resistant plastic. Plug in upper housing with controller and amplifying stage, reset push-button (A) with fault indication on the top of the device.

Plug socket with terminals grounding strip and retaining screws.

Seven openings provided for external wire connection (B).

Terminals: 2 x AWG 16 (2 x 1.5 mm²)

Technical Data

Operating voltages IFS 110 IM

110/120 V, +10/-15%, 50/60 Hz

Trial for ignition period: 3, 5 or 10 s

Ignition time: approx. 2, 3 or 7 s

Remote reset: yes

Power consumption: 9 VA

Output for ignition transformer by means of semi-conductors – no switch contacts.

Output voltage for valves and ignition transformer = supply voltage.

Contact load: max. 1 A per output

Total load: max. 2 A

Flame rod: 220 VAC

Ionisation current: > 1 μ A

Reaction time: < 2 s

No. of valves: 2

Protection in the device:

micro fuse T2AH 250 V slow-blow, acc. IEC 127-2/5

Fault indicator:

LED in the reset button and connection for external fault indicator

Ambient temperature:

-4 °F to 140 °F (-20 °C to + 60 °C)

Typ of enclosure: NEMA 1

Fitting position: arbitrary

Weight: 1.57 lbs (0.71 kg)

Accessory

Test Adapter (Fig. 12)

A test set is available for a fast and safe checking of all functions of IFS 110 IM. Furthermore, all essential measurements can be carried out when commissioning a gas installation: order No. 8 435 3050

Note

At industrial furnaces the blower for combustion air is energized by the furnace control via a approved timing relay. Therefore, a special terminal for connecting the blower is not provided.

The flame signal and ignition lines must be connected separately.

As ignition lines we recommend:

FZLK 1/7 order No. 0 425 0409

FZLSi 1/6 order No. 0 425 0410

Length of ignition line max. 15 ft (5 m).

Do not place ignition line in a metal tube. In case of UV control we would recommend to connect in series for each burner control an additional fuse

The UV-detector may see the ignition spark. On principle, only authorized specialists shall carry out a (remote) reset, by constantly checking the burner to be reset.

The automatic burner control unit can only work properly if the energized duration is longer than the trial for ignition period / safety time.

Type code

Type	IFS 110 IM -W-10/2 /2 N
Version 110 IM	
Standard version = without letter	
Restart on flame failure = W	
t _{SA} [s]	Trial for ignition period = 3, 5 or 10 s
t _{SB} [s], V2	Flame failure response time for valve 2 = 1 or 2 s
t _{SB} [s], V1	Flame failure response time for valve 1 = 1 or 2 s
Mains voltage 110/120 V~ = N	



Fig. 13

Flame control with flame rod

(Fig. 13)

An alternating voltage (220 V) is applied between the ionisation electrode, which projects into the flame, and the grounded burner. As soon as the flame is established a small current flows through it and is rectified by the flame. The electronic amplifying stage detects only this direct current signal which, after amplification, is used to energize a relay. A flame cannot be simulated.

The flame must touch the burner tube. High voltage cable (not screened) should be used as ionisation lead in order to avoid losses through insulation: FZLSi 1/6 order No. 0 425 0410.

The cable should be laid as far away as possible from power cords and sweep radiation sources. Several ionisation leads can be laid together – possibly in plastic pipes.

Do keep away from the furnace wall for approx. 7⁷/₈" (20 cm); this applies particularly to long ionization leads up to 150 ft (50 m).

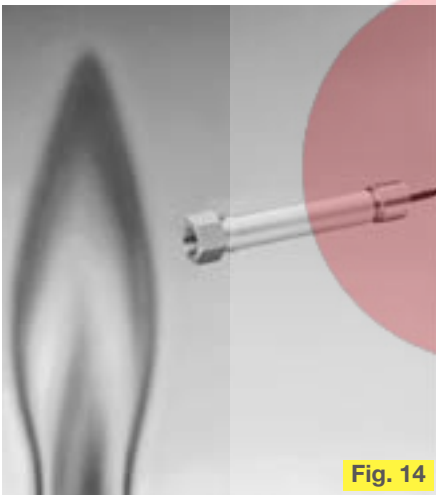

Fig. 14

Flame control with UV-detector

(Fig. 14)

The UV-detector (UVS 6 or UVS 8) mainly consists of a tube which is sensitive to light and of electronic components. The tube responds to the ultra violet (UV) radiation from a gas flame, it does not react to sunlight and light from filament lamps.

Note

A d.c. ammeter is put into the flame signal line in order to measure the flame signal current. The amperage must be at least 1 µA and is usually between 5 and 30 µA. Voltage surges, short-circuits or leakage-path in the flame signal line result in an alternating signal which will be registered as a fault condition with both types of control.

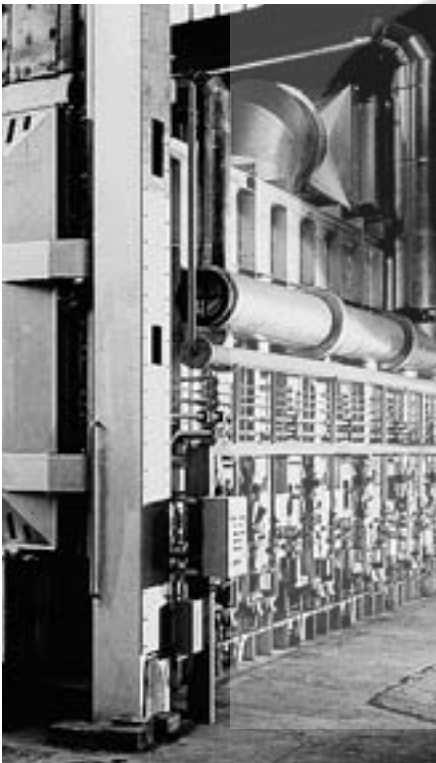

We reserve the right to make technical changes designed to improve our products without prior notice.